

<b>BHAVNAGAR MUNICIPAL CORPORATION</b>		
<b>Notice Inviting On -Line Tender</b>		
<b>E-Tender Notice No. 15 BMC/DRAINAGE/AMRUT 2.0/tender/2024-25</b>		
Department Name	:-	Drainage Department (Bhavnagar Municipal Corporation)
IFB No.	:-	BMC/DRAINAGE/Amrut 2.0/tender/2023-24
Name of Project	:-	Atal Mission for Rejuvenation and Urban Transformation 2.0
Name of Work	:-	CONSTRUCTION OF STORE AREA FOR DRAINAGE DEPARTMENT, BMC AT F.P. NO. 66 UNDER T.P. SCHEME NO. 7 ADHEWADA, BHAVNAGAR
Estimated Contract Value (INR)	:-	RS 2,83,33,059.00
Class of Registration required	:-	Class "B" and ABOVE
Period of Completion (in month )	:-	12 (TWELVE)
Bid Call (Nos)	:-	Open ( Percentage Rate Tender)
Tender Currency Type	:-	Single
Tender Currency Settings	:-	Indian Rupee (INR)
Joint Venture	:-	N.A.
Rebate	:-	N.A.
<b>Amount Details</b>		
Bid Document Fee	:-	Rs.4,248/- (Rs. Four Thousand Two Hundred Forty Eight Only) (only D.D.)
Bid Document Fee Payable To	:-	Commissioner, Municipal Corporation, Bhavnagar
Bid Security / EMD (INR)	:-	Rs. 2,83,331/- (Rs. Two Lakh Eighty Three Thousand Three Hundred and Thirty One Only)
Bid Security / EMD in favour of	:-	Commissioner, Municipal Corporation, Bhavnagar
Defect liability period	:-	Two year
EPF registration no.	:-	The bidder shall have to submit valid certificate of registration for having EPF number and ESIC number.
Security deposit	:-	The bidder shall have to pay 10% security deposit at the time of agreement, out of which 5% shall be in the form of Bank Guarantee of schedule bank, in the form of FDR/DD addressed to The Commissioner, Bhavnagar Municipal Corporation, and remaining 5% shall be deducted from every running bill as retention money. The retention money so deducted will be refunded along with the final bill upon the successful completion of project and submission of certificate of EIC. The 5% SD will be converted in the performance security and shall be released at the end of defect liability period and on production of certificate of EIC.
<b>Tender Dates</b>		
Bid Document Downloading Start Date	:-	13-02-2025
Bid Document Downloading End Date	:-	05-03-2025 up to 18:00 hrs.
Pre Bid Meeting	:-	24-02-2025 up to 12:00 hrs.
Last Date & Time of Receipt of Bid (Submission Of Bid)	:-	10-03-2025 up to 16:00 hrs.
Bid Validity Period	:-	180 Days
<b>Remarks</b>	:-	<b>CLASS OF REGISTRATION REQUIRED FOR BIDDER MUST BE " B " AND ABOVE. Demand Draft for tender fee &amp; Emd shall be submitted in Electronic Formate through online scanning alongwith all the supporting documents such as Registration, Bank Solvency Certificate etc, while uploading thebid. Offer of those will be opened whose EMD &amp; Tender fee is received electronically alongwith the bids, however for the purpose of realization of Demand Draft bidder shall send them in original alongwith all the required documents mentioned in the tender documents through RPAD/Speed post/Reg AD so as they reach to the office of Exe. Engg. - Drainage Dept. Bhavnagar Municipal Corporation during office hours between 13-02-2025 to 10-03-2025 16:00 pm. Penaltative action shall identinitiated for not submitting the supporting documents in original to E.E. by bidder. Hard copy will not be accepted and considered.Successfull Bids (Preliminary &amp; Technical Bid), if possible will be opened on the 10-03-2025, 17:30 pm at the City Engineer's office - BMC</b>
Bid Opening Date	:-	10-03-2025 at 17:30 hrs.
<b>SPECIAL CONDITION FOR SUBMISSION OF EMD,BG,SD,FD:-</b>	:-	<b>Henceforth Bank Guarantee, Earnest Money Deposit, Security Deposit, Fixed Deposit, Demand draft of State Bank Of India will not be accepted.</b>
<b>Other Details</b>		
Officer Inviting Bids	:-	Executive Engineer, Drainage Department, Municipal Corporation, Bhavnagar
Bid Opening Authority Members in committee	:-	(1) Executive Engineer (2) City Engineer (3) Chief Accountant (4) Chief Auditor
Address	:-	Drainage Department
<b>E-tendering relate instructions</b>		
<p>(1) Bidders can download the tendar document free of cost from the website. <a href="http://www.nprocure.com">www.nprocure.com</a></p> <p>(2) Bidders have to submit Technical bid as well as Price bid in Electronic for only on <a href="http://www.nprocure.com">www.nprocure.com</a> website till the Last Date &amp; time for submission.</p> <p>(3) Offers in physical from will not bi accepted in any case.</p> <p>(4) Free vendor training camp will be organized every Saturday between 4.00 to 5.00 p.m. at (n)code solutions - A Division of GNFC Ltd., Bidders are requeste take benefit of the same. All bids should be digitally signed, for details regarding digital signature certificate related training involved, kindly, contact the below mentioned address.</p> <p>(n) Code Solutions A Division of GNFC Ltd. 403, GNFC Infotower, Bodakdev, Ahemedabad - 380 054 (India) Tel. +91 79 26854511/12/13 (EXT :501,512,516,525) +91 79 26857316/17/18 (EXT :501,512,516,525) Fex.+91 79 26857321,40007533 E-mail :nprocure @gnvfc.net Web-site :www.nprocure.com Toll Free :1800-233-1010(EXT :501,512,516,525)</p>		

**BHAVNAGAR MUNICIPAL CORPORATION**  
**Online e-Tender (SHORT TERM )**

**E-Tender Notice No. 15 BMC/DRAINAGE/AMRUT 2.0/tender/2024-25**



**Bid Documents For**  
**CONSTRUCTION OF STORE AREA FOR DRAINAGE DEPARTMENT, BMC AT**  
**F.P. NO. 66 UNDER T.P. SCHEME NO. 7 ADHEWADA, BHAVNAGAR**

**VOLUME –I**  
**TECHNO COMMERCIAL BID**

<b>Milestone Dates</b>	
Date of issue of placing tender document start date	13/02/2025
Last date of Online Tender Submission	05/03/2025 18:00 hour
Last date of submission of physical Documents	10/03/2025 16:00 hour
Online Opening date of the Technical Bid(If convenient.)	10/03/2025 17:30 hour

**CLIENT:**  
**Executive Engineer (Drainage Department),**  
**Bhavnagar Municipal Corporation.,**  
**Sir Mangalsinhji Road,**  
**Bhavnagar- 364 001**



**BHAVNAGAR MUNICIPAL CORPORATION Drainage Department**



**Online e-Tender**

**E-Tender Notice No.15 BMC/DRAINAGE/AMRUT 2.0/tender/2024-25**

Bhavnagar Municipal Corporation invites On-Line Percentage rate tender by single stage two bid system for the work of "CONSTRUCTION OF STORE AREA FOR DRAINAGE DEPARTMENT, BMC AT F.P. NO. 66 UNDER T.P. SCHEME NO. 7 ADHEWADA, BHAVNAGAR. ".

Detailed tender notice & Bid Documents will be available on the website: <https://bmc.nprocure.com> for bidding etc. from date : 13/02/2025 to 05/03/2025 till 18.00 Hrs. Detailed tender notice can be seen on <https://bmcgujarat.com>. Further details, if any, can be obtained from Executive Engineer, Drainage Department.

Executive Engineer  
Bhavnagar Municipal Corporation  
Bhavnagar  
Date: 13/02/2025  
Place: Bhavnagar

<b>DETAIL TENDER NOTICE:</b>		
<b>Tender Notice No.</b>	Online E- Tender Notice No.15 BMC/DRAINAGE/AMRUT 2.0/tender/2024-25	
<b>Organization Name</b>	BHAVNAGAR MUNICIPAL CORPORATION	
<b>Department Name</b>	<b>DRAINAGE</b> Executive Engineer Bhavnagar Municipal Corporation., Sir Mangalsinhji Road, Bhavnagar- 364 001	
<b>Scope of work</b>	<b>CONSTRUCTION OF STORE AREA FOR DRAINAGE DEPARTMENT, BMC AT F.P. NO. 66 UNDER T.P. SCHEME NO. 7 ADHEWADA, BHAVNAGAR</b>	
<b>Tender Type</b>	PERCENTAGE RATE WORK Open Online	
<b>Bidder Nationality</b>	LCB (Local Competitive Bidding)	
<b>Qualification of Bidder</b>	Duly registered with State/ Central Govt./Municipal Corporations/P.S.U./ Agencies in Class "B" or above.	
<b>Type of Contract</b>	PERCENTAGE RATE Work	
<b>Bidding Currency</b>	Single (Rupees)	
<b>JV/Consortium</b>	Not Allowed	
<b>Schedule of E-Tender</b>	Document downloading last date & time	13/02/2025 to 05/03/2025, 18:00 Hrs.
	Pre-Bid Meeting date &time	24/02/2025 up to 12:00 hrs.
	Last date & time of online Bid submission	05/03/2025 up to 18:00 hrs.
	Physical submission of EMD, Document Fee, PQ bid and Supporting documents	On or before 10/03/2025 up to 16:00 hrs at Office of Executive Engineer (Drainage Department), BMC, Bhavnagar
	Opening of PQ Bid (Online) & Technical Bid	10/03/2025 at 17:30 hrs. at the office of city engineer, BMC, Bhavnagar
	Opening of Price Bid (Online)	Intimation through letter/ n -procure
	Bid validity period	180 days on receipt of tender
	Project Duration	12 Months
<b>Payment Details</b>	Document Fee	Rs. 4,248.00 (Rs. 3,600.00 + 18% GST)
	EMD	Rs. 2,83,331.00
	Estimated Value	Rs. 2,83,33,059.00
<b>General Terms &amp; Conditions</b>	<p>Bidders who wish to participate in this E-Tender will have to procure valid digital certificate as per information Technology Act 2000. Bidders can procure this certificate from any of the Government approved certifying agency i.e. (n) Code Solution.</p> <p><b>DOWNLOAD OF TENDER DOCUMENT: -</b> The tender document for these work are available only in Electronic format which can be download free of cost by the bidder.</p> <p><b>SUBMISSION OF TENDER:-</b></p>	



	<p>Tenderer shall submit their offer in Electronic format on above mentioned website on or before the scheduled date and time as mentioned, after Digitally Signing the same.</p> <p>Bidders shall upload the tender documents after submitting the DD details for tender fees and EMD in form of DD/Bank Guarantee details online. The Demand Draft toward Tender Document fees can be submitted along with Earnest Money Deposit before the due date as specified above. This should be as per details given online and it should be drawn before last date of the uploading of the tender.</p> <p>The intending bidders shall have to submit the following documents in Physical form along with the EMD and tender fees.</p> <ul style="list-style-type: none"> <li>(a) Documents required for evaluation as sought in different annexure dully digitally signed.</li> <li>(b) Power of attorney.</li> <li>(c) Company's profile and certificate of Registration of company under the law.</li> </ul> <p>The Bidder should submit price Bid electronically only. <b>Price bid in physical form shall Not be accepted</b> and any such offer if received by Bhavnagar Municipal Corporation same will be out rightly rejected.</p> <p>Technical bid in physical form is not required to be submitted by all bidders. However, non submission of technical bid does not absolve bidders from and liability of the tender. Only successful bidders have to submit the technical bid duly signed in physical form upon intimation from BMC .</p>
	<p><b>OPENING OF TENDER: -</b></p> <p>The Technical Bid will be opened on the specified date online on website <a href="https://bmc.nprocure.com">https://bmc.nprocure.com</a> Bidders or their representative who wish to participate in online tender opening can log on to <a href="https://bmc.nprocure.com">https://bmc.nprocure.com</a> on the due date and time, mark their presence and participate in online tender opening. Bidders who wish to remain present at Bhavnagar Municipal Corporation, Only one representative of each firm will be allowed to remain present.</p>
<p><b>Information for online participation</b></p>	<ul style="list-style-type: none"> <li>1. Internet site address for e-Tendering activities will be <a href="https://bmc.nprocure.com">https://bmc.nprocure.com</a></li> <li>2. Interested bidders can view detailed tender notice and download tender documents from the above mentioned website.</li> </ul>

	<p>3. Bidders who wish to participate in online tender have to register with the website through the “New User Registration” link provided on the home page. Bidder will create login id &amp; password on their own in registration process.</p> <p>4. Bidders who wish to participate in this tender need to procure Digital Certificate as per Information Technology Act-2000 using that they can digitally sign their electronic bids. Bidders can procure the same from any of the CCA approved certifying agencies, or they may contact (n) code Solution at below mentioned address and they will assist them in procuring the same. Bidders who already have a valid Digital Certificate need not to procure the same. In case bidders need any clarification regarding online participation, they can contact</p> <p>M/S (n)code Solution  301, G.N.F.C. Info Tower,  Near grant Bhagwati Hotel,  Ahmedabad 380015, India.  Tel: +91 79 26857316  Tel: +91 79 26857317  Tel: +91 79 26857318  E-Mail:  URL: <a href="https://bmc.nprocure.com">https://bmc.nprocure.com</a></p> <p>5. Bidders who wish to participate in e-Tender need to fill data in predefined forms of tender fee, EMD, PQ (Technical) or experience details and Price bid only.</p> <p>6. Bidder should upload scan copies of reference documents in support of their eligibility of the bid.</p> <p>7. After filling data in predefined forms bidders need to click on final submission link to submit their encrypted bid.</p> <p>Bidder can also submit Document Fees, EMD, Technical bid document &amp; Reference Documents in hard copy if such instructions are given by tendering authority.</p>
<p><b>Qualifying Criteria</b></p>	<p><b>Evaluation Criteria:</b></p> <p><b>(a) Bidder has to must submit all the filled up annexure and adequate detailed documents with technical bid/physical submissions for fulfilling qualifying criteria , failing witch BMC will disqualify the bidder without giving chance for submission of missing documents.</b></p> <p>Mainly tenderer shall fulfill following for pre-qualification,</p>

	<p>(a) Experience of having successfully completed "<b>similar works</b>" during last <b>07</b> years either of the following :</p> <p>(1a) Three similar completed works, each costing not less than amount equal to 40% of the Estimated Cost. OR</p> <p>(2a) Two similar completed works, each costing not less than amount equal to 50% of the Estimated Cost. OR</p> <p>(3a) One similar completed works, each costing not less than amount equal to 80% of the Estimated Cost</p> <p><b>"Similar works" means," Successfully completed work including RCC frame/structure/building including CC road, water supply and drainage network.</b></p> <p>(b) Financial Turnover during last 3 years, ending 31<sup>st</sup> March of previous financial year, should be at least 30% of Estimated Cost. An attested copy of annual turnover for last 3 years should be enclosed.</p> <p>(c) <b>Solvency certificate from bankers of schedule bank / Nationalized bank amounting 35.00 lacs. Tenderer has to submit higher Amount of bank solvency if so desired by Commissioner</b></p> <p>(d) An attested copy of registration with MES, PSU, various departments of State Government, Municipal Corporation, CPWD etc.</p> <p>(e) List of the works already completed <b>in last 7 years</b> in prescribed Performa as per Annexure-I and attested copies of certificates from head of the office concerned for completion of the works.</p> <p>Following enhancement factors will be used for the cost of works executed and financial Turnover figures to common base for the value of the works completed in India.</p> <table border="1"> <thead> <tr> <th>Financial Year</th> <th>Multiplying factor</th> </tr> </thead> <tbody> <tr> <td>One (2023-24)</td> <td>1.0</td> </tr> <tr> <td>Two (2022-23)</td> <td>1.1</td> </tr> <tr> <td>Three (2021-22)</td> <td>1.21</td> </tr> <tr> <td>Four (2020-21)</td> <td>1.33</td> </tr> <tr> <td>Five (2019-20)</td> <td>1.46</td> </tr> <tr> <td>Six (2018-19)</td> <td>1.6</td> </tr> <tr> <td>Seven (2017-18)</td> <td>1.76</td> </tr> </tbody> </table> <p>Bidder should indicate actual figures of costs and amount or the work executed in Annexure – I without accounting for the above mentioned factors.</p>	Financial Year	Multiplying factor	One (2023-24)	1.0	Two (2022-23)	1.1	Three (2021-22)	1.21	Four (2020-21)	1.33	Five (2019-20)	1.46	Six (2018-19)	1.6	Seven (2017-18)	1.76
Financial Year	Multiplying factor																
One (2023-24)	1.0																
Two (2022-23)	1.1																
Three (2021-22)	1.21																
Four (2020-21)	1.33																
Five (2019-20)	1.46																
Six (2018-19)	1.6																
Seven (2017-18)	1.76																

	<p>(f) Declaration regarding the work on hand with the tenderer shall also be given in prescribed Performa as per Annexure-II. Attested copies of work orders, interim certificates if any shall also be attach as supporting documents.</p> <p>(g) Attested copy of partnership deed, power of attorney etc. In case of work done on sublet basis the certificate of respective department must be submitted with bid.</p> <p>Municipal Commissioner reserves the right to accept or reject any or all the tenders without assigning any reasons.</p> <p><b>Note: Joint Venture is not allowed.</b></p>
<p><b>Contact person</b></p>	<p>For further details of any query regarding the tender            Contact to:            Executive Engineer (Drainage Department),            Bhavnagar Municipal Corporation.,            Sir Mangalsinhji Road, Bhavnagar- 364 001            Phone No: (O)-0278-2424801 to 10            Mobile no. 9925009293            E-mail address: bmcdrainage@gmail.com</p>

**Executive Engineer  
 Bhavnagar Municipal Corporation,  
 Bhavnagar**

**BHAVNAGAR MUNICIPAL CORPORATION  
TENDER DOCUMENT  
I N D E X**

1.0	NOTICE INVITING TENDER.....	9
2.0	INFORMATION TO TENDERER : .....	13
3.0	CHECK LIST.....	14
4.0	GENERAL DETAILS OF WORK IN BRIEF : .....	15
5.0	INSTRUCTION TO TENDERERS.....	16
6.0	ADDITIONAL INSTRUCTIONS TO THE TENDERERS.....	39
7.0	GENERAL CONDITION OF CONTRACT.....	41
8.0	SPECIAL CONDITIONS OF CONTRACT .....	84
9.0	PERCENTAGE RATE TENDER & CONTRACT FOR WORKS .....	90
10.0	PREAMBLE TO TECHNICAL SPECIFICATION (PRICE - BID).....	93
11.0	MEMORANDUM.....	95
12.0	GENERAL SPECIFICATIONS .....	96
13.0	DETAILS SPECIFICATION OF MATERIAL .....	98
14.0	GENERAL TECHNICAL SPECIFICATION FOR BUILDING WORKS.....	121
15.0	ITEMWISE DETAILED TECHNICAL SPECIFICATIONS .....	123
16.0	IMPORTANT INSTRUCTION TO TENDERER.....	344
17.0	ADVANCE STAMP RECEIPT .....	346
18.0	FORM OF BID SECURITY (BANK GUARANTEE).....	348
19.0	FORM OF CONTRACT AGREEMENT .....	350
20.0	FORM OF PERFORMANCE SECURITY (BANK GUARANTEE) .....	352
21.0	VENDOR LIST .....	353

## 1.0 NOTICE INVITING TENDER

### (A) RECEIPT AND OPENING OF TENDER :

Online Tenders will be received from the established and reliable contractors on or before 18.00 hours on website bmc.nprocure.com. The tender received after due time and date specified will not be accepted.

### (B) NAME OF WORK: CONSTRUCTION OF STORE AREA FOR DRAINAGE DEPARTMENT, BMC AT F.P. NO. 66 UNDER T.P. SCHEME NO. 7 ADHEWADA, BHAVNAGAR

ESTIMATED COST	Rs 2,83,33,059.00 including defect liability
Defect Liability	24 month
EARNEST MONEY DEPOSIT	Rs. 2,83,331.00/- as per detailed tender notice
TIME LIMIT	12 (Twelve Months)
Document Fee	Rs. 4,248.00 (Rs. 3,600.00 + 18% GST) as per detailed tender notice
Registration required	as per detailed tender notice

### (C) OPENING OF TENDERS :

The tenders will be opened online in presence of bidders and opening authority subject to receipt of Tender Fees, EMD and other Documents in hard copy. The tenders will be opened in **two stages** i.e. **Technical Bid and Commercial Bid**.

### (D) PURCHASE OF TENDER DOCUMENTS :

Tender Documents can be downloaded from bmc.nprocure.com up to as per detailed tender notice.

**Tender documents fees of Rs. 4,248.00 /-** per set which is required for submission of tender towards the cost of tender documents in cash, pay order or by demand draft of any nationalized bank, in favor of "**The Commissioner, Bhavnagar Municipal Corporation**" payable at Bhavnagar and shall be submitted along with **Tender fee**, EMD and other documents. The cost of the Tender Documents will not be refunded in any circumstances. The Bhavnagar Municipal Corporation shall not be liable for any postal delay in any case.

### (E) CONTRACT PERIOD :

The total contract period is hereby fixed as **12 (Twelve Months)** from the 15<sup>th</sup> Day of issuance of Letter of Intent(LOI).

**No Execution work shall be permitted on site from 1<sup>st</sup> June to 30<sup>th</sup> September. However material procurement shall be permitted.**

- (F) Tenderer must comply with and agree to all instructions & requirements in the Notice and in the Instructions to Tenderers, including requirements in the Contract Documents.
- (a) All tenders must be submitted in the prescribed Tender form.
  - (b) Each Tender must be accompanied by the completion Schedule.
  - (c) Each tender must be accompanied by the Tender Security (Earnest Money Deposit) as specified.
  - (d) The successful tenderer shall execute the Contract Agreement within fifteen days after the date of Letter of Intent (LOI).
  - (e) The successful Tenderer will be required to furnish a performance bond (Security Deposit) of an amount equal to (5%) Five percent of the tendered amount.
  - (f) The successful Tenderer shall furnish insurance in accordance with the contract documents.
  - (g) The Bhavnagar Municipal Corporation may withhold issuance of the Notice of proceed for a period not exceeding fifteen days after the date of execution of the contract agreement.
  - (h) The tender and tender guarantee bond (Earnest Money Deposit) shall be submitted by the Agency in whose name tender has been issued. Transfer of tender documents to any other party is prohibited.
  - (i) All intending tenderers will have to purchase digital signatures in order to participate in the online bidding process.
  - (j) All the applicant contractors are required to have their own employers' code number under EPF Act, 1952 and are required to comply the applicable provisions of said statute regularly and totally. And certificates i.e. ESIC and EPF to be submitted in hard copies.

(G) RECEIPT OF TENDER DOCUMENTS :

The following details are to be submitted online on [bmc.nprocure.com](http://bmc.nprocure.com) :

- a. Document fees and EMD Details
- b. Commercial Bid

The following details shall be submitted in hard copy at prescribed address :

- a. Tender fees in prescribed format
- b. Earnest Money Deposit in prescribed format
- c. Annexure I to X along with all necessary supporting documents

Please note that commercial bid shall not be submitted in hard copy under any circumstances. This will hold the tender liable for rejection.

(H) Tender Validity Period :

The validity period of the tender submitted for this work shall be of one hundred twenty (180) calendar days from the last days of receipt of tender for this work and the Tenderer shall not be allowed to withdraw or modify the tender offer on his own during the validity period.

(I) Rights Reserved :

Without assigning any reason, The Bhavnagar Municipal Corporation reserves the right to reject the lowest or any other or all tenders or part of its. To waive any informality or irregularity in any tender, which in the opinion of the Bhavnagar Municipal Corporation does not appear to be in its best interest and the tenderer shall have no cause of action or claim against the Bhavnagar Municipal Corporation or its officers, employee, successors or assignees for rejection of this tender.

The Bhavnagar Municipal Corporation further reserves the right to withhold issuance of the notice to proceed, after execution of the contract agreement by the successful Tenderer. The Bhavnagar Municipal Corporation is not obliged to give reasons for any such action.

During Tender validity period, if any Tenderer withdraws or makes any modifications or additions in the terms and conditions on his own in this tender, then The Bhavnagar Municipal Corporation shall without prejudice to any right or remedy be at liberty to reject the tender and forfeit the Earnest Money Deposit in full. Such Tenderer may be disqualified from tendering for further works under the jurisdiction of The Bhavnagar Municipal Corporation.

The Bhavnagar Municipal Corporation reserves the right to increase or decrease the scope of work and split the tender in two or more parts without assigning any reason even after the award of contract.

(J) ESIC Condition:

All the applicant contractors are required to have their own employers code number under EPF Act, 1952 and are required to comply the applicable provisions of said state regularly and totally. And certificates i.e., ESIC and EPF to be submitted in hard copies.

**Scope of Work:**

**"CONSTRUCTION OF STORE AREA FOR DRAINAGE DEPARTMENT, BMC AT F.P. NO. 66 UNDER T.P. SCHEME NO. 7 ADHEWADA, BHAVNAGAR "**

**The Broad scope of work for the Project is described as below:**

The contractor shall be responsible for the design and construction of a store area for the drainage department at F.P. No. 66 of T.P. Scheme No. 7 (Adhewada), Bhavnagar. The total allocated plot area is 7243 m<sup>2</sup>, out of which 5365 m<sup>2</sup> will be developed for the current store requirements, leaving 1878 m<sup>2</sup> for future expansion.

- The contractor must ensure the development of the site as per the proposed layout, with separate entry and exit points to facilitate the smooth transit of utility vehicles.



- It is the duty of the contractor to provide three designated parking spaces within the site. These spaces shall include one for the parking of trucks and utility vehicles, another for DG set trailer parking, and a third for visitors, staff, and working personnel. All parking areas must be covered with appropriate sheds and paved with paver blocks for durable and functional flooring.
- A pipe storage area is to be constructed by the contractor, ensuring a stable and durable surface made of hard murrum to accommodate the storage of pipes. This area must be designed to meet operational requirements and facilitate easy access for handling and storage activities.
- The contractor shall construct a maintenance area to support the repair and cleaning of utility vehicles. This maintenance area must include the provision of a grease trap to effectively separate grease from wastewater before its disposal into the drainage network. Additionally, the maintenance area must comprise of an attached toilet, a rest area for drivers, a dedicated storage space for parts, machinery, and equipment, as well as an office. The contractor is also required to allocate space and construct an underground tank to ensure a reliable water supply for the service area.
- An office building must be constructed by the contractor, equipped with essential amenities including a pantry and drinking water facilities. The office building should be designed for ease of access and optimal functionality for the staff and operational needs.
- The contractor is required to construct a warehouse for storage of pump valve and other mechanical equipment. The warehouse shall include handicap-accessible toilets and common toilet facilities complying with the National Building Code (NBC) guidelines, 2016. The structure must be designed with a self-supporting roof utilizing translucent FRP sheets to allow natural light inside. Furthermore, the warehouse should be equipped with turbo-ventilators to ensure effective ventilation and maintain air quality.
- It is also the responsibility of the contractor to execute landscaping works as per the proposed layout. The landscaping should enhance the aesthetic appeal of the site while ensuring it complements the functionality of the overall development.
- All components of the store area must be constructed by the contractor to ensure the provision of all necessary utilities, including power, water, and drainage connections, to support the efficient operation of the site. The work shall be carried out adhering to the requirements of the drainage department of Bhavnagar Municipal Corporation.

SIGNATURE OF THE CONTRACTOR.

EXECUTIVE ENGINEER,  
BHAVNAGAR MUNICIPAL CORPORATION,  
BHAVNAGAR.

**2.0 INFORMATION TO TENDERER :**

1. Tender validity period **180 days (One hundred & Eighty days) from the last date of receipt of tender**
2. Earnest Money Deposit **Rs. 2,83,331.00 as per detailed tender notice**
3. Security Deposit **Five Percent (5%) of contract Amount. or as per prevailing Govt.'s GR**
- 3.A Retention Money **5%, Deducted from every bill or as per prevailing Govt.'s GR**
4. Time of Completion **For the complete contract 12(Twelve Month)**
5. Period for O & M Contract NA
6. Period of liability for defects. **24 months after completion of work**
7. Penalty for delay Zero Point one percent (0.1%) of the contract price per day, maximum up-to ten percent of the contract price.
8. Last date of download of tender Date :- as per detailed tender notice upto 18.00 hrs from bmc.nprocure.com
9. Last date of submission of online Tender Date :-as per detailed tender notice
10. Last date of submission of Tender fees, EMD and other Documents As per detailed tender notice
11. Pre-Bid : Bidders shall have to submit their queries in hard copy only within 10 days from starting date of online tender uploaded.

Executive Engineer/CITY ENGINEER,  
BHAVNAGAR MUNICIPAL CORPORATION,  
BHAVNAGAR.

### 3.0 CHECK LIST

1. Tenderers to note last date and time of submission of Tender Fees, EMD and other documents and that they are to be posted by **Registered Post A. D. / Speed Post only.**
2. Tender (Technical Bids and Documents) should be duly sealed and the covering envelope is to be only super scribed as **"CONSTRUCTION OF STORE AREA FOR DRAINAGE DEPARTMENT, BMC AT F.P. NO. 66 UNDER T.P. SCHEME NO. 7 ADHEWADA, BHAVNAGAR "**
3. Tender Security Bond for Earnest Money Deposit should be submitted as per Articles **IT-07** (Earnest Money Deposit)
4. Conditional tender will be rejected outright by the Bhavnagar Municipal Corporation, without giving any reason.
5. All information as demanded should be submitted.
6. Information regarding capability etc. as per clause No.**IT-04** (General Performance Data) should be submitted in hard copy along with tender fee and EMD.
7. Please verify before SEALING that Tender (Technical Bids and Documents) are signed, wherever required in each and every respect.

#### 4.0 GENERAL DETAILS OF WORK IN BRIEF :

1. NAME OF WORK : CONSTRUCTION OF STORE AREA FOR DRAINAGE DEPARTMENT, BMC AT F.P. NO. 66 UNDER T.P. SCHEME NO. 7 ADHEWADA, BHAVNAGAR
2. Estimated cost of the work : Rs. 2,83,33,059.00 including Defect Liability.
3. Amount of Earnest Money Deposit : Rs. 2,83,331.00 per detailed tender notice
4. Tender cover to be superscribed as :

NAME OF WORK : CONSTRUCTION OF STORE AREA FOR DRAINAGE DEPARTMENT, BMC AT F.P. NO. 66 UNDER T.P. SCHEME NO. 7 ADHEWADA, BHAVNAGAR

1. Tender Notice (online) No. as per detailed tender notice
2. Name and Address of Tenderer.

EXECUTIVE ENGINEER, DRAINAGE DEPARTMENT  
BHAVNAGAR MUNICIPAL CORPORATION,  
BHAVNAGAR.

## 5.0 INSTRUCTION TO TENDERERS

### IT-01 GENERAL :

The Contract documents may be secured in accordance with the notice Inviting Tender for the work called. The work shall include supply of materials necessary for construction of the work.

### IT-02 INVITATION TO TENDER :

The Bhavnagar Municipal Corporation hereinafter referred to as the Corporation will receive tenders for "**CONSTRUCTION OF STORE AREA FOR DRAINAGE DEPARTMENT, BMC AT F.P. NO. 66 UNDER T.P. SCHEME NO. 7 ADHEWADA, BHAVNAGAR**" as per the specifications in the tender documents. The tenders shall be opened in the office of the City Engineer, BMC, Bhavnagar in the presence of tenderers or their representatives who choose to remain present. The Corporation reserves the right to reject the lowest or any other or all tenders or part of it which in the opinion of the Corporation does not appear to be in its best interest, and the tenderer shall have no cause of action or claim against the corporation or its officers, employees, successors or assignees for rejection of his tender.

### IT-03 LANGUAGE OF TENDER :

Tenders shall be submitted in English, and all information in the tender shall also be in English, Information in any other language shall be accompanied by its translation in English. Failure to comply with this may make the tender liable to reject.

### IT-04 QUALIFICATIONS OF TENDERERS :

A. Tenderer shall be required to submit the enlisted documents in hard copy along with the Technical Bid, EMD and tender fees. **If documents are insufficient or it does not match the required criteria mentioned below, then the Price Bid of the tenderer shall not be opened.**

Mainly tenderer shall fulfill following for pre-qualification,

(a) Experience of having successfully completed similar works during last 7 years either of the following :

(1a) Three similar completed works, each costing not less than amount equal to 40% of the estimated Cost.

OR

(2a) Two similar completed works, each costing not less than amount equal to 50% of the Estimated Cost.

OR

(3a) One similar completed works, each costing not less than amount equal to 80% of the Estimated Cost

**"Similar works" means," Successfully completed work including RCC frame/structure/building including CC road, water supply and drainage network. "**

- (b) Turnover during last 3 years, ending 31<sup>st</sup> March of previous financial year, should be at least 30% of Estimated Cost. An attested copy of annual turnover for last 3 years should be enclosed.
- (c) Solvency certificate from bankers of schedule bank / Nationalized bank amounting 35.00 lacs. Tenderer has to submit higher Amount of bank solvency if so desired by Commissioner.
- (d) An attested copy of registration with MES, various department of State Government, Municipal Corporation, CPWD etc.
- (e) List of the works already completed in last **7 years** in prescribed Performa as per Annexure-I and attested copies of certificates from head of the office concerned for completion of the works. **As a supporting documents completion certificate should be signed by equivalent to Executive Engineer or above post accepted only.**

Following enhancement factors will be used for the cost of works executed and financial figures to common base for the value of the works completed in India.

Financial Year	Multiplying factor
One (2023-24)	1.0
Two (2022-23)	1.1
Three (2021-22)	1.21
Four (2020-21)	1.33
Five (2019-20)	1.46
Six (2018-19)	1.6
Seven (2017-18)	1.76

Bidder should indicate actual figures of costs and amount for the work executed in Annexure – I without accounting for the above mentioned factors.

- (f) Declaration regarding the work on hand with the tenderer shall also be given in prescribed Performa as per Annexure-II. Attested copies of work orders, interim certificates if any shall also be attach as supporting documents.
- (g) Attested copy of partnership deed, power of attorney etc.
- (h) ~~In case of Joint Venture the lead partner should meet minimum 51% of experience as well as financial criteria. However lead partner is solely responsible for the entire project.~~

**(B) Joint Venture is not allowed.**

(C) Tenderer shall submit only one tender for the work put to this tender.

**IT-05 TENDER DOCUMENTS :**

Printed and online documents and set of drawings shall comprehensively be referred to as Tender documents. The several sections forming the documents are the essential parts of the contract and a requirement occurring in one shall be binding as though occurring in all. They are to be taken as mutually explanatory and describe and provide for complete works.

**IT-06 EXAMINATION BY TENDERERS :**

- A. At his own expenses and prior to submitting his tender, each tenderer shall (a) examine the contract Documents, (b) visit the site and determine local conditions which may affect the work including the prevailing wages and other pertinent cost factors, (c) familiarize himself with all Central, State and local laws, ordinance, rules, regulations and codes affecting the material supply including the cost of permits and licenses required for the work and (d) correlate his observations, investigations, and determinations with the requirements of the Tender Documents.
- B. The tender quantity is approximate and may increase or decrease. Any increase or decrease in quantity will not entitle tenderer to claim any extra over the quoted rate.
- C. Tender Documents be completed by legible ink, checked in a responsible manner, signed, stamped and returned together with the Tender Security Bond by the stipulated date, which shall form the Tender.

The Tenderer is required to complete :

- (i) The form of tender, including the Appendices thereto Tender Security Bond and the Tender summary duly signed and stamped.

All the pages in which entries are required to be made by the tenderer are contained in the tender documents and the tenderer shall not take out or add to or amend the text of any of the documents except in so far as may be necessary to comply with any addenda issued pursuant to Clause IT-17 hereof.

**IT-07 EARNEST MONEY DEPOSIT:**

- A Each Tender must be accompanied with Earnest Money of **Rs.2,83,331.00** per detailed tender notice in the following manner.  
100% of EMD amount shall be in the form of Cross Demand Draft of Local Schedule/nationalized Bank or Bank Guarantee of Schedule/nationalized bank( en cashable at Bhavnagar) in favor of the Municipal Commissioner, Bhavnagar Municipal Corporation payable at Bhavnagar.

The tender bond, shall be valid for a period of not less than One hundred and twenty (180) days from the last date of receipt of tender and shall comply with the requirements for Bond as stipulated in the general conditions of contract. The tender guarantee bond will be held by the Corporation as a guarantee that the tenderer, if awarded the contract, will enter into the contract agreement in good faith and furnish the required bonds. Any tender not accompanied by a Tender Guarantee in the form of earnest money deposit as stated above for the sum stipulated in the Tender Document will be summarily rejected.

- B. The Earnest Money Deposit will be refunded to the unsuccessful tenderers after the award has been finalized.
- C. The Earnest Money Deposit (Tender guarantee) will be forfeited in the event, the successful tenderer fails to accept the contract and fails to submit the Performance Guarantee Bond to the owner as stipulated in this tender documents within ten days after receipt of notice of award of contract. In such case owner may disqualify the tenderer from tendering for further works, under the jurisdiction of the Corporation (BMC).
- D. The Earnest Money Deposit of the successful tender shall be returned after the performance guarantee bond, as required, is furnished by the contractor.
- E. No interest shall be paid by the owner on any tender guarantee.

**IT-08 INCOME TAX CLEARANCE CERTIFICATE :**

In view of the latest circular of IT Department IT clearance certificate is not required. However the contractor shall give xerox copy of the PAN card and last return's acknowledgement copy.

**IT-09 PREPARATION OF TENDER DOCUMENTS :**

Tenderers are requested to note the following while preparing the Tender Documents

- A. Technical bid, EMD and Tender fees shall be submitted on the Tender Form bound herein in English. All tender items and statements shall be properly filled in. Numbers shall be stated both in words and in figures where so indicated, and signatures of all persons signing shall be in longhand.
- B. Technical Bid shall be accompanied by the prescribed tender security bond and other required documents and drawings. All witnesses and sureties shall be persons of status and probity and their full names, occupations and address shall be stated below their signatures. All signatures in the Tender Documents shall be dated.
- C. Variations to the Contract Documents requested by the tenderer may be affixed to the Tender Document in the space available and duly signed and stamped. Such variations may be approved or refused by the Engineer at the time of adjudications of Tenders, and in either case the Engineer is not obliged to give reasons for his decisions.
- D. Delivery of Tenders shall comply with Notice inviting tenders as to place, date and time.



**E. Price Bid shall be submitted online only.**

**IT-10 SUBMISSION OF TENDERER DOCUMENT :-**

1. Tenderer shall submit his tender in sealed covers as described under:

(i) COVER-1 : Documents for qualifications for the work of **"CONSTRUCTION OF STORE AREA FOR DRAINAGE DEPARTMENT, BMC AT F.P. NO. 66 UNDER T.P. SCHEME NO. 7 ADHEWADA, BHAVNAGAR"** along with E.M.D and Tender Fees. Also mention the name of tenderer, address, tender notice number etc. on the cover and to be submitted to the Executive Engineer (Projects), Bhavnagar Municipal Corporation, MangalSinhji Road, Bhavnagar - 364001.

2. Tenderer shall be required to submit the enlisted documents along with their bid (Volume-I) (i.e. Cover-1). If this bid founds insufficient documents then the Price Bid of the tenderer shall not be opened.

(a) The tender shall be accompanied by Earnest Money Deposit as stated in para IT-07(A).

(b) All relevant documents for qualifications and details sought in All Annexure.

3. (a) List of tools, plants and equipment's with tenderer in detail.

(b) Technical establishment/staff of the tenderer in required Performa with their names, qualifications and experience.

(c) Tenderer shall furnish along with the tender, information regarding Income tax circle of the district in which he is assessed for income tax with PAN No.

4. Submission of a tender by a tenderer shall mean that he has read this notice and all contract documents and has made himself aware of the scope and specifications of the work to be done and of conditions and nature of required quantities of materials stores, tools and plants etc. that may be required by him in carrying out the work and of local conditions and laws and bylaws of the Government, Bhavnagar Municipal Corporation and other factors bearing influence on the execution and cost of the works.

5. Technical Bid shall be received by Registered Post A.D. or by Speed Post through Postal Authority only by the " Executive Engineer (Drainage Department), 1st Floor , Bhavnagar Municipal Corporation, Mangal Sinhji Road, Bhavnagar - 364001, as per Mile stone dates and time stated in tender.

If possible the same will be opened on the date of pre-qualification opening on line 12.00 hours onwards in the presence of the tenderers, who shall remain present in the office of "City Engineer, Bhavnagar Municipal Corporation, Bhavnagar. Late tenders (i.e. tenders received after the specified time of opening), delayed tender (i.e. tenders received before the time of opening but after due date and the time of receipt of tender) shall not be considered at all. Tenders received by Registered Post A.D./ Speed Post after the time and the date specified in the tender notice shall not be received by the client from the postman. Such tenders if received will not be opened and will stand rejected.

6. Tender shall stand rejected if:
  1. The tenderer shall submit the tender which satisfied each and every conditions laid down in the notice tender documents, failing which the tender will be liable for rejection.
  2. Tenderer's tender/quotation containing conditions shall be liable for rejection out rightly without assigning any reason for the same.
  3. Stipulates his own conditions.
  4. Does not quote his rates inclusive of all taxes , insurance, labor overhead charges, contractor's profit, royalties etc. except GST.
  5. Does not disclose the full names and address of all his partners in the case of partnership firm.
  6. Does not pay the Earnest Money Deposit by Demand Draft/B.G. and Tender Fees with the Bid (Cover-1).
  7. Does not submit the tender before the stipulated time and specified date in the office of The Executive Engineer, Drainage Department, BMC central office, as directed.
  8. Does not attached the document mentioned.
  9. The tenderer proposes any alteration in the work specified in the tender or in the time limit allowed for carrying out the work or any other condition.
  
7. The tenderer shall submit the tender which satisfies each and every conditions laid down in this notice and tender documents failing which the tender is liable for rejection.
  
8. Notice inviting tenders shall be a part of the contract documents.
  
9. Acceptance of tender/quotation will rest with the competent authority of Bhavnagar Municipal Corporation who does not bind himself to accept the lowest and reserves the right to accept or to reject any or all quotations/tenders and no reasons will be given for acceptance or rejection thereof.
  
10. Tender once accepted shall be binding on the contractor even if the formal agreement is not signed.
  
11. Tender once offered cannot be withdrawn except with the permission of Commissioner, Bhavnagar Municipal Corporation, Bhavnagar.
  
12. The successful tenderer shall be required to enter in to agreement with Municipal Corporation after placing the LOI for the said work from BMC.
  
13. The tenderers are requested to study complete specification of work quoted.
  
14. Bhavnagar Municipal Corporation reserves the right to open or not to open any or all Price-bid without assigning any reason thereof.

**IT-11 TENDER VALIDITY PERIOD :**

The validity period of the tender submitted for this work shall be of **one hundred eighty (180)** Calendar day from the last date of receipt of tender and that the tenderer shall not be allowed to withdraw or modify the tender offer on his own during the validity period. The tenderer will not be allowed to withdraw the tender or make any

modifications or additions in the terms and conditions of his own in his tender. If this is done then the owner shall, without prejudice to any right or remedy, be at liberty to reject the tender and forfeit the Earnest Money Deposit in full.

**IT-12 SIGNING OF TENDER DOCUMENTS :**

If the Tender is made by an individual it shall be signed with his full name above his current address. If the tender is made by a Proprietary firm it shall be signed by the proprietor above his name and the name of his firm with his current address.

If the tender is made by a firm in partnership it shall be signed by all the partners of the firm above their full names and current addresses, or by a partner holding the power of attorney for the firm signing the Tender in which case a certified copy of the power of attorney shall accompany the Tender. A certified copy of the partnership deed, current addresses of all the partners of the firm shall also accompany the tender.

If the tender is made by a limited company or a limited Corporation, it shall be signed by a duly authorized person holding the power of attorney for signing the Tender in which case a certified copy of the power of attorney shall accompany the Tender. Such limited company or Corporation may be required to furnish satisfactory evidence of its existence before the contract is awarded.

All witnesses and sureties shall be persons of status and probity and their full names, occupations and addresses shall be stated below their signatures. All signatures in the Tender document shall be dated.

**IT-13 WITHDRAWAL OF TENDERS :**

If, during the Tender validity period, the Tenderer withdraws his Tender, the Tender Security (Earnest Money) shall be forfeited and the Tenderer may be disqualified from tendering for further works under the jurisdiction of BHAVNAGAR MUNICIPAL CORPORATION.

**IT-14 INTERPRETATIONS OF TENDER DOCUMENT :**

Tenderers shall carefully examine the tender documents and fully inform themselves as to all the conditions and matters which may in any way effect the work or the cost thereof. Should a tenderer find discrepancies or omission from the specifications or other documents, or should be in doubt as to their meaning, he should at once address query to the Divisional Head provided for concerned authority as referred in the Tender Document in Clause GC-01 (Definitions and interpretations) of the (General Condition of Contract). Any resulting interpretation of the Tender documents will be issued to all Tenderers as an addenda corrigendum. Verbal clarification and / or information given by the BMC / Consulting Engineer shall not be binding on the Municipal Corporation.

**IT-15 ERRORS AND DISCREPANCIES IN TENDERS :**

In case of conflict between the figures and words in the rates, the rates expressed in words shall prevail and apply in such cases.

**IT-16 MODIFICATION OF DOCUMENTS :**

Modification of specifications and extension of the closing date of the tender, if required, will be made by an addendum. Copies of each addendum will be sent to all tenderers. These shall be Signed and shall form a part of tender. The tenderer shall not add to or amend the text of any of the documents except in so far as may be necessary to comply with any addenda.

**IT-17 ADDENDA**

Addenda form part of the contract documents & full consideration shall be given to all addenda in the preparation of tenders. Tenderers shall verify the number of addenda issued online, if, any and acknowledge the receipt of all Addenda in the Tender. Failure to acknowledge may cause the Tender to be rejected.

The Engineer of the owner may issue Addenda to advise Tenderers of changed requirements. Such addenda may modify previously issued Addenda.

**IT-18 TAXES AND DUTIES ON MATERIAL :**

The quoted rates should be inclusive of all taxes , insurance, labor overhead charges, constrictor's profit, royalties etc. except GST. Other duties on material obtain for the works from any source shall be borne by the Contractor. 'P' and 'C' form shall not be supplied by the Municipal Corporation.

**All the taxes, excluding GST shall be borne by the Contractor and EPF data/certificate shall be submitted at the time of all the running bill by the contractor.**

**IT-19 EVALUATION OF TENDERS : Tenders shall be evaluated as per the qualification criteria mentioned.**

**IT-20 EVALUATION OF TIME REQUIRED FOR COMPLETION :**

The time required for completion of work shall be considered as indicated by the tenderer in the completion schedule attached with the tender. The completion period mentioned in this schedule is to be reckoned from 15<sup>th</sup> day from the date of LOI to proceed. Total completion period is calendar months from 15<sup>th</sup> day from date of issue of LOI and tenderers should adhere to this completion time.

**IT-21 POLICY FOR TENDER UNDER CONSIDERATION :**

Tenders shall be termed to be under consideration from the opening of the tender until such time an official announcement of award is made.

While tenders are under consideration, tenderers and their representative or other interested parties are advised to refrain from contacting by any means Municipal Corporation or representatives on matters related to the tenders under study. The Engineer's representative if necessary will obtain clarification on tenders by requesting information from any or all the

tenderers either in writing or through personal contact, as may be necessary. The tenderers will not be permitted to change the substance of his tender after price submission. Non-compliance with this provision shall make the tender liable for rejection.

**IT-22 PRICES AND PAYMENTS :**

The tenderer must understand clearly that this is a storm water/sewage water infrastructure project, the price quoted are for the total works or the part of the total works quoted for and include all costs due to materials labour, equipment, supervisions, any restorations, other services, taxes and royalties etc. excluding GST and to include all extras to cover the cost. No claim for additional payment beyond the prices quoted will be entertained and the tenderer will not be entitled subsequently to make any claim on any ground excepting for the condition laid down in GC-35 (Price Adjustment).

**IT-23 PAYMENT TERMS :**

The terms of payment are defined in the General Conditions of Contract. The Municipal Corporation shall not under any circumstances relax, their terms of payment and will not consider any alternative payment terms. Tenderers should therefore in their own interest note this provision to avoid rejection of their tenders.

**IT-24 AWARD :**

Award of the Contract or the rejection of tenders will be made during the Tender validity period stated in the Notice Inviting Tenders.

- A. After all contract contingencies are satisfied and the Notice of Award is issued, the successful Tenderer shall execute the Contract Agreement within the time stated in the Notice Inviting Tenders and shall furnish the Bond as required herein. The Contract Agreement shall be executed in the form stipulated by the owners.
- B. If the Tenderer receiving the Notice of Award fails or refuses to execute the Contract Agreement within the stated time limit or fails or refuses to furnish the Bond as required herein, the BMC may annul his award and declare the tender security forfeited.
- C. Corporation, Partnership firm or other consortium acting as the Tenderer and receiving the Award shall furnish evidence of its existence and evidence that the officer signing the Contract Agreement & Bonds for the Corporation, partnership firm or other consortium acting as the Tenderer is duly authorized to do so.[ JV not allowed]

**IT-25 SIGNING OF CONTRACT :**

The successful tender shall be required to pay the security deposit and to execute the contract within 15 days of receipt of intimation to execute the contract, failing which the Municipal Corporation will be entitled to annul the award and forfeit the Earnest Money Deposit. The person to sign the contract document shall be person detailed in Article IT-12.

**IT-26 DISQUALIFICATION :**

A tender shall be disqualified and will not be taken for consideration if :-

- (a) The outer envelope does not show on the outside the reference of bid and thus get opened before the due date of opening (as per Article IT-10 i.e. Submission of Tender Document).
  - (b) The tender Security Deposit is not deposited in full and in the manner as specified as per Article IT-07 i.e. Earnest Money Deposit.
  - (c) The tender is in a language other than English or does not contain its English Translation in case of other language adopted for tender preparation.
  - (d) The tender documents are not signed by an authorized person (as per Article IT - 12 i.e. signing of tender documents).
  - (e) The general performance data for qualification not submitted fully (As per Article IT-04 General Performance Data).
  - (f) The tenderer does not agree to deposit security amount as specified (as per Article IT-25 i.e. Signing of Contract)
  - (g) The tenderer does not agree to payment terms defined as per Article IT-23 i.e. Payment Terms.)
  - (h) Conditional tender.
- A. Tenderer may further be disqualified if :
- (a) Price variation is proposed by the Tenderer on any principles other than provided in the Tender Documents.
  - (b) Completion schedule offered is not consistent with the completion schedule defined and specified in tender documents.
  - (c) The validity of tender is less than that mentioned in Article IT-11 i. e. Tender Validity Period.
  - (d) Any of the page or pages of tender is/are removed or replaced.
  - (e) All corrections or pasted slips are not initialed by tenderer.
  - (f) Any erasure is made in the tender.

**IT-27 PERFORMANCE GUARANTEE (SECURITY DEPOSIT) :10% as under or as per latest/prevaling GR by Govt.**

As a contract security the tenderer to whom the award is made shall furnish a performance guarantee (Security Deposit) for amount equal to Five percent (5%) of the contract price to guarantee the faithful performance completion and maintenance of the works of the contract in accordance with all the conditions and terms specified herein and to the satisfaction of the Engineer and ensuring the discharge of all obligations arising from the execution of contract, in one of the forms mentioned below.

- (a) 100% By a demand draft of a Scheduled/Nationalized bank Acceptable to owner on the Bhavnagar Branch.  
OR
- (b) 100% by a fixed deposit receipt of a Scheduled Bank or Government securities duly, located at Bhavnagar pledged in favour of the Municipal Commissioner, Bhavnagar Municipal Corporation, Bhavnagar.  
OR
- (c) 100% By Bank Guarantee of a Scheduled /Nationalized Bank and Bank Guarantee encashable at Bhavnagar City

The performance guarantee shall be delivered to the Municipal Corporation within Ten (10) days of the notice of award.

Security deposit shall be paid in time and if it is paid next fifteen(15) days from the date of LOI then the penalty of 0.065 % per day of the amount of security deposit shall be recovered from the contractor while receiving the security deposit. On due performance and completion of the contract in all respects, the performance guarantee (security deposit) which will be released after the total completion of contract after payment of final bill. It is clarified that the amount of security deposit shall be collected on the basis of Contract Price and not on the basis of estimated amount put to tender. If contractor fails to pay S.D. in stipulated time it will cause of cancellation of award and forfeit EMD etc.

Additional Five percent (5%) security deposit shall be deducted from running bills as **retention money** which will be released after completion of defect liability period but if contractor wants to convert such amount in the form of Fix Deposit Receipt in the name of the commissioner, during intermediate period can be permitted after such approval by commissioner.

**IT-28 STAMP DUTY :**

The successful tenderer shall have to enter into an agreement on a non-judicial stamp paper of Rs. 300/- as per the form of the agreement approved by the Municipal Corporation, Bhavnagar.

The agreement shall be executed on stamp paper worth Rs. 300/-.

The Surety shall be executed on stamp paper worth Rs. 300/-.

Additional Stamp of amount equivalent to 4.25% of Security deposit is to be paid in case of SD paid in cash or in the form of Fixed Deposit receipt

**IT-29 BRAND NAMES :**

Specific references in the specifications to any materials by tender's name, or catalogue number shall be construed as establishing a standard or quality and performance and not as limiting competition and the tenderer in such cases, may at their option freely use any other product with prior approval, provided that it ensures and equal or higher quality than the standard mentioned and meets Municipal Corporation approval.

**IT-30 NON-TRANSFERABLE :**

Tender documents are not transferable.

**IT-31 COST OF TENDERING :**

The owner will not defray expenses incurred by Tenderers in tendering.

**IT-32 DEFECTION OF TENDER :**

The Tender for the work shall remain open for a period of 180 calendar days from the date of receipt of the tenders for this work and that the tenderer shall not be allowed to withdraw or modify the offer on his own during the period. If any tenderer withdraws or makes any modifications or additions in the terms and conditions on his own, then the Municipal Corporation,

shall without prejudice to any right or remedy, be at liberty to reject the tender and forfeit the earnest money in full.

**IT-33 CHANGE IN A QUANTITY :**

The Bhavnagar Municipal Corporation reserves the right to waive any informality in any tender and to reject one or all tenders without assigning any reasons for such rejections and also to vary quantities of items or group as specified in the Schedule of price as may be necessary. Claim what so ever by the contractor on the basis of variation of quantities shall not be entertained.

**IT-34 NEW EQUIPMENT AND MATERIAL ;**

All materials, equipment and spare parts thereof shall be new, unused and originally coming from manufacturer's plant to the Corporation. The rebuilt or overhauled equipment/materials will not be allowed to be used on work.

**IT-35 RIGHTS RESERVED ;**

The BMC reserves the right to reject any or all tenders, to waive any informality or irregularity in any tender without assigning any reasons. The BMC further reserves the right to withhold issuance of the notice to proceed, after execution of the contract agreement, for the period of time stated in the notice inviting tenders and no additional payment will be made to the successful tenderer on account of such withholding. The BMC is not obliged to give reasons for any such action.

**IT-36** Municipal Commissioner reserves the right to reduce the scope of work and split the tender in two or more parts without assigning any reason even after the award of contract.

**IT-37** deleted

**IT-38** The scope of work is clearly mentioned in the tender documents. The contractor shall have to carry out the work in accordance with the details specifications. No conditions will be accepted. The conditional tender will be liable to be rejected.

**IT-39** Bhavnagar Municipal Corporation may appoint **PMC/TPI/BMC** supervisor for monitoring, supervision and material inspection for this project/work, the work agency has to convey activity schedules, coordinate and support them during the execution without any objection.

**Contractor has to arrange all equipment's and test materials like pipes, steel, bricks, cement, Concrete etc. for inspection /test at factory for bought out items and at site for other items executed at site or at laboratory at his own cost and submit QAP for approval and 'inspection call' time to time in prescribed form to TPI agency through Executive Engineer ( Drainage Department), BMC.**

**IT-40 Contractor has to display sign board showing details of items and specifications at site as per instruction of Eng. In charge. This is mandatory as per order of state vigilance commission.**



**IT-41 GENERAL INSTRUCTIONS & ERRATA**

1. In case of any minor/major change in the alignment of proposed line due to site condition the department will be at the sole discretion and in such case work agency can not arise any objection.
2. Cement concrete blocks of crushing strength not less than 100 kg/cm<sup>2</sup> will be allowed without any extra cost for construction of chambers (manhole, scrapper manholes, vertical drop arrangement) and instructed that any Fly ash bricks containing lime will not allowed for any brick masonry work.
3. In the case of Existing RCC road slab, bidder has to calculate it as Hard rock strata and In the case of Existing Asphalt Paver road as Soft rock strata for Excavation.  
As per above consideration Bidder has to calculate excavation of different soil strata at site of alignment and quote the rate for Excavation items " for specified lift and all type strata ".
4. Contractor has to excavate trench with manually labour in congested roads. In every alignment it should be inspected by trial pit or cross trenches up to required depth to detect the existing network of BSNL, PGVCL or other company's underground cable network, BMC's or other's water/sewer pipe line and submit a sketch of existing network to finalize the final alignment of sewer line will be laid and after instruction/permission of engineer in charge for excavation further work can be started. In case of any service line's breakages, damages shall be repaired and restored by contractor at his own cost.
5. Quantities of RCC pipes etc. shown in BOQ are tentative, contractors are instructed to procure as per actual requirement at site but not more than shown in BOQ.
6. Agency have to carry out level and alignment survey of the proposed network before execution of work and submit it in auto cad 2006.in soft and hard copy to the department for approval. Existing Bench Marks can be obtain from the Project department, BMC. Agency must cross check R.L.s of Bench Marks This survey should be carried out in & with consultation with BMC's technical representative.

SIGNATURE OF THE CONTRACTOR.

Executive Engineer /CITY ENGINEER,  
BHAVNAGAR MUNICIPAL CORPORATION  
BHAVNAGAR.

**ANNEXURE-I TO XI FOR PRE-QUALIFICATION  
TO BE FILLED IN BY TENDERER**

**ANNEXURE-I**

**Performa for list of works of similar nature already completed by the Tenderer during last 7 years ( as a supporting documents completion certificate should be signed by equivalent to Executive Engineer or above post only accepted)**

Sr. No.	Name of Work and Place	Cost completion	on complete work	Time take in months to complete work	Client Name	Date Completion	of
1.	2.	3.	4.	5.	6.	7.	8.

**Note :** Bidder shall give completion certificate from client. In absent of such completion certificate, experience shall not be considered for evaluation. If completion certificate covers "Similar work (as per IT-04) with other work" then bidders shall have to submit copies of final bill indicating similar work or certificate of amount indicating "Similar work" from relevant authority.

Signature of the Contractor with seal.

Place:

Date:

**ANNEXURE-II**

Performa for declaration regarding works on hand with the tenderer:

---

Sr. No.	Name of Work and Place	Estimated Cost	Date of issue of work order	Stipulated period of completion	Amount of work done	Brief detail of delay if any	Name of client
1.	2.	3.	4.	5.	6.	7.	8.

---

Signature of the Contractor with seal.

Place:

Date:

(Note: Amount of work done in Column 6, should be given up to the month previous to the month in which tenders are invited).

## ANNEXURE-III

## Details to be furnished for financial capability of tenderers

Rs. in lacs

Sr. No.	Financial year	Turnover of civil works only	Net profit during the year	Net asset	Net Cash accrual	Net worth	Remarks
1	2	3	4	5	6	7	8
1	2023-24						
2	2022-23						
3	2021-22						

Note : Tenderer shall give last 3 years balance sheets and certificate of Chartered Accountant.

Signature of the Contractor with seal.

Place:

Date:

**ANNEXURE-IV**

**AFFIDAVIT**

**NAME OF WORK : " CONSTRUCTION OF STORE AREA FOR DRAINAGE DEPARTMENT, BMC AT F.P. NO. 66 UNDER T.P. SCHEME NO. 7 ADHEWADA, BHAVNAGAR "**

- 1.0 I, the undersigned, do hereby certify that all the statements made in the required attachments/Annexure(s), while bidding for the above mentioned work are true and correct.
- 2.0 The undersigned also hereby certifies that neither our firm M/s \_\_\_\_\_ nor any of its constituent partners have abandoned any work in India nor any contract awarded to us for such works has been rescinded during last five years, prior to the date of this bid.
- 3.0 The undersigned hereby authorize(s) and request(s) any bank, person, authorities, government or public limited institutions, firm or corporation to furnish pertinent information deemed necessary and requested by the BMC to verify our statements or our competence and general reputation.
- 4.0 The undersigned understands and agrees that further qualifying information may be requested, and agrees to furnish any such information at the request of the BMC.
- 5.0 The BMC and its authorized representatives are hereby authorized to conduct any inquiries or investigations to verify the statements, documents, and information submitted in connection with this application and to seek clarification from our bankers and clients regarding any financial and technical aspects. This Affidavit will also serve as authorization to any individual or authorized representative of any institution referred to in the supporting information, to provide such information deemed necessary and requested by yourselves to verify statements and information provided in the Tender or with regard to the resources, experience and competence of the Applicant.

\_\_\_\_\_  
Signed by the authorized signatory of the firm

\_\_\_\_\_  
Title of the office

\_\_\_\_\_  
Name of the firm

\_\_\_\_\_  
Date

**Note:** The affidavit format as indicated above to be furnished on non judicial stamp of Rs.300

**ANNEXURE-V**

**Details of Technical staff with tenderer**

<b>Sr. No.</b>	<b>Name of personnel</b>	<b>Qualification</b>	<b>Total experience</b>	<b>Who is proposed to be posted for this work</b>

**ANNEXURE-VI**

**List of tools, plants and equipment's with tenderer (Format as per tenderer's choice)**

**ANNEXURE-VII**

**List of tools, plants and equipment's to be deployed by the tenderer for the work (Format as per tenderer's choice).**



**ANNEXURE-VIII**

**Contractors Schedule for execution of work**

<b>Sr. No.</b>	<b>Description of Activity</b>	<b>Start month and date and completion month and Date</b>

**ANNEXURE-IX**

**Structure and Organization of the Company**

1. Name of Applicant
2. Nationality of Applicant
3. Office Address
  - Telegraphic Address
  - Telephone No. (O) (M)
  - Telex No.
  - Fax No.
  - Email address :
4. Year and location of establishment
5. The Applicant is
  - a) An individual
  - b) A proprietary firm
  - c) A firm in partnership
  - d) A limited company or Corp.  
(if a firm in partnership)
6. Attach the organization chart showing the structure of the organization including the names of the Directors and position of officers.
7. For how many years has your organization been in business of similar work under it's present name ? what were your fields when your organization was established?
8. In how many of your projects penalties were imposed for delays?  
(Please give details)
9. In which field of civil engineering construction do you claim specialization and interest ?

**Signature of Applicant.**

**Date :**

**ANNEXURE-X**

**ARBITRATION/LITIGATION HISTORY**

Name of Applicant
-------------------

Applicants should provide information on any history of litigation or arbitration resulting from contract executed in the last five years or currently under execution.

Year	Project Name	Name of Client	Cause of litigation and matter in dispute	Award for or against the applicant	Disputed amount (in Indian Rs.)	Actual Awarded amount (in Indian Rs.)

Date:

Signature

Name

## 6.0 ADDITIONAL INSTRUCTIONS TO THE TENDERERS

### (For Drainage Department Works only)

1. Successful contractor shall have to work under supervision of BMC representative and/or representative of PMC agency appointed by the Bhavnagar Municipal Corporation. However, decision of the Bhavnagar Municipal Corporation shall be final and binding to the Contractor.
2. Successful Contractor shall have to provide site office for BMC supervisors without any extra cost if instructed by engineer in charge(the Executive Engineer ,Drainage Department).
3. The bidder understood that this is an up gradation project, Hence, The contractor shall take utmost care during excavation to protect existing underground utilities. All water main lines / water connections, storm / sewage main / house connection, electricity cable, telephone cable, gas pipeline or any other utilities and structures shall be protected by the contractor. However, if met during excavation, any damage caused shall be rectified by the contractor at the earliest and all the rectification cost shall be borne by the contractor. If the bill for rectification work (if carried out by the concerned agencies / departments) is put by such agencies / department, the same shall be payable by the contractor, if not so it will be deducted and recovered from the running bills to be paid to contractor.
4. Contractor may construct manhole intermittently/before laying of lines. But in case if any manhole has to be abandoned due to any reason. Contractor has to bear the cost for the same.
5. The whole work of excavation, laying and jointing of pipes shall have to be carried out with the help of leveling instruments only. The leveling instrument to be used for the purpose shall be provided by the contractor. In no case the work shall be allowed to be carried out with help of boning rod.
6. The contractor will have to construct shed for storing controlled and valuable materials like cement and other materials etc. purchased by the contractor or supplied by the department. The material will be taken for use in the presence of the Department person. No materials will be allowed to be removed from the site of work.
7. No foreign exchange would be released by Department for the purchase of material, plants and machineries required for the execution of the work contracted for.
8. No price escalation shall be paid in any case.
9. The surplus excavated earth, after backfilling the trenches shall have to be removed from the site as directed.

After compaction and consolidation, if any short fall of earth is found then contractor has to bring the required quantity to meet shortfall at his own cost. Moreover, if any settlement of road after reinstatement is observed during the defect liability period of the work, Contractor shall be fully responsible for the defective work and patches/ depression/ settlement shall be repaired

with quarry spall or metal at contractor's own cost. If contractor fails to repair the patches/ depression /settlement in time, corporation will repair it at all risk and cost of contractor. Surplus earth shall not be disposed off in a way that leads to nuisance to the public or BMC.

SIGNATURE OF THE CONTRACTOR.

EXECUTIVE ENGINEER,  
BHAVNAGAR MUNICIPAL CORPORATION,  
BHAVNAGAR

## **7.0 GENERAL CONDITION OF CONTRACT**

### **GC-01 DEFINITIONS AND INTERPRETATIONS :**

- 1.0 In the contract documents, as herein defined the following words and expression used shall, unless, repugnant to the subject or context thereof, have the following meanings assigned to them.
- 1.1 The "Owner/Municipal Corporation, Bhavnagar represented by Municipal Commissioner / City Engineer / Executive Engineer, any officer authorised by the Municipal Corporation.
- 1.2 The "Contractor" shall mean the person or the persons, firm of company whose tender has been accepted by the owner and includes his legal representative successors and permitted assignees.
- 1.3 The "Engineer-in-charge" shall mean the person designated as such by the owner from time to time and shall include those who are expressly authorised by the Municipal Corporation to act for and on its behalf for the operation of this contract.
- 1.4 "Engineer - in - charge's Representative" shall mean any Engineer or Asstt. to the Engineer-in-charge designated from time to time by the Engineer-in-charge to perform duties set forth in the Tender documents whose authority shall be notified in writing to the Contractor by the Engineer-in-charge.
- 1.5 "Tender" The offer or proposal of the Tenderer submitted in the prescribed form setting forth the prices for the work to be performed, and the details thereof.
- 1.6 "Contract Price" shall mean total money payable to the Contractor under the contract documents.
- 1.7 "Addenda" shall mean the written or graphic notices prior to submission of tender which modify or interpret the contract documents.
- 1.8 "Contract Time" - The number of consecutive calendar months for the completion of work as stated in the executed contract agreement.
- 1.9 "Contract" shall mean agreements between the parties for the execution of works including therein all contract documents.
- 1.10 "Tender document" shall mean Designs, Drawings, specifications, agreed variations, if any, and such other documents constituting the tender and acceptance thereof.
- 1.11 "The Sub-Contractor" means any person, firm or company (other than the contractor) to whom any part of the work has been entrusted by the Contractor with the written consent of the Engineer-in-charge and the legal personnel representative, successors and permitted assignees of such person, firm or company.
- 1.12 The Specifications shall mean all directions' the various technical specifications provisions and requirements attached to the contract which pertain to the method and manner or performing

the work to the quality of the work and the materials to be furnished under the contract for the work and any order(s) or instruction (a) there under.

It shall also mean the latest Indian Standards Institution Specifications for or relative to the particular work or part thereof, so far as they are not contrary to the Tender specifications or I.S.I. specifications, and in absence of any tender specifications, the specifications of any other country applied in India as a matter of Standard Engineering practice and approved in writing by the Engineer-in-charge with or without modifications.

- 1.13 The "Drawing" shall include maps, plans, tracings or prints thereof with any modifications approved in writing by the Engineer-in-charge and such other drawings, as may, from time to time, be furnished or approved in writing by the Engineer-in-charge in connection with the work.
- 1.14 The "Work" shall mean the works to be executed in accordance with the context or the part thereof as the case may be and shall include extra, additional altered or substituted works as required for the purpose of the Contract. It shall mean the totally of the work by expression or implication envisaged in the contract and shall include all material, equipment and labour required for or relative or incidental to or in connection with the commencement, performance and completion of any work and/or for incorporation in the work.
- 1.15 The "Permanent work "means works which will be incorporation in and form part of the work to be handed over to the owner by the contractor on completion of the contract.
- 1.16 The "Temporary Work" shall mean all temporary works of every kind required in or about the execution, completion and maintenance of the work.
- 1.17 "Site shall mean the land and other place on, under, on or through which the work is to be carried out and any other lands or places provided by the Municipal Corporation for the purpose of the Contract together with any other places designated in the Contract as forming part of the site.
- 1.18 "The Construction Equipment" means all appliance/equipment's of whatever nature required in or for execution, completion or maintenance of work or temporary works (as hereinafter defined) but does not include materials or other things intended to form or forming part of the permanent work.
- 1.19 "Notice in Writing or Written Notice" means a notice written, types or printed form delivered personally or sent by Registered post to the latest know private of business address at Registered Office of the Contractor.
- 1.20 The "Alteration/Variation order" means an orders given in writing by the Engineer-in-charge to effect additions to or deletion from and alterations in the work.
- 1.21 "Final Test Certificate" shall mean the final test Certificate issued by the owner within the provisions of the Contract.
- 1.22 The "Completion Certificate" shall mean a certificate to be issued by the Engineer-in-charge when the work has been completed to his satisfaction.

- 1.23 The "Final Certificate" shall mean the final certificate issued by the Engineer-in-charge after the work is finally accepted by the owner.
- 1.24 "Defect Liability Period" shall mean the specified period between the issue of completion Certificate and the final certificate as specified in the tender.
- 1.25 "Approved" shall mean approved in writing including subsequent modification in writing of previous verbal approval and "Approval" means approved in writing including as aforesaid.
- 1.26 "Letter of Intent" shall mean an intimated by a letter to tenderer that the tender has been accepted in accordance with provisions contained therein.
- 1.27 "Order" and "Instruction" shall respectively mean any written order or instruction given by the Engineer-in-charge within the scope of his powers in terms of the Contract.
- 1.28 "Running Account Bill" shall mean a Bill for the payment of "On Account" money to the contractor during the progress of work on the basis of work done and the non-perishable materials to be incorporated in the work supplied by the Contractor.
- 1.29 "Security Deposit" shall mean the deposit to be held by the owner as security for the due performance of contractual obligations.
- 1.30 Retention Money shall mean the money retained from R.A.Bill for due completion of "NET WORK".
- 1.31 Unless otherwise specifically stated, the masculine gender shall include the feminine and natural genders and vice-a-versa and the singular shall include the plural and vice-versa.

**GC-02 LOCATION OF SITE AND ACCESSIBILITY :**

The site of works is within the limits of Bhavnagar Municipal Corporation. It is served by all weather roads and Western Railway Broad Gauge line. The intending Tenderer should inspect the site and make himself familiar with site conditions and available communication facilities.

Non availability of access/roads shall in no case be the cause to condone any delay in the execution of the work or be the cause for any claims or extra compensation.

**GC-03 SCOPE OF WORK :**

The bidder are instructed that this is drainage pipe line up gradation project. The scope of work is defined broadly in the special conditions of Contract and specifications. The Contractor shall provide all necessary materials equipment and labour etc. for the execution and of the work till completion. All materials that go with the work shall be approved by the Engineer-in-charge prior to procurement and use.

Owner at his discretion may endeavor to provide water to the Contractor at the owner's source of supply at one point at the rate charged for such works.



The contractor shall make his own arrangement for the distribution pipe networks from the source of supply after getting prior permission for the same from the Engineer-in-charge. Supply of water shall not be free and the necessary charges as fixed by the Local Body shall have to be paid by the contractor.

However, owner does not guarantee the supply of water and this does not relieve the contractor of his responsibility in making his own arrangements and for the timely completion of the work as stipulated.

**POWER SUPPLY :**

The Contractor shall have to make his own arrangement for power supply.

**LAND FOR CONTRACTOR'S FIELD OFFICE, GODOWN& WORKSHOP:**

Owner will not provide land required for; Contractors shall have to make his own arrangement for the same.

**GC-04 RULING LANGUAGE :**

The language according to which the contract shall be constructed and interpreted shall be English. All entries in the contract documents and all correspondence between the contractor and the Municipal Corporation or the Engineer shall be in English. All dimensions for the materials shall be given in metric units only.

**GC-05 INTERPRETATION OF CONTRACT DOCUMENT :**

1. The provisions of the General Conditions of Contract and special conditions of contract shall prevail over those of any other documents of the contract unless specifically provided otherwise. Should there be any discrepancy, inconsistency error or omission in the several documents forming the contract, the matter may be referred to the Engineer-in-charge for his instructions and decision. The Engineer-in-charge's decision in such case shall be the final and binding to the contractor.
2. Works shown upon the drawings but not described in the specifications or described in the specific specifications without showing on the drawings shall be taken as described in the specifications and shown on the drawings.
3. The heading and the marginal notes to the clauses of those general conditions of contract or to the specifications or to any other part of tender documents are solely for the purpose of giving a concise indication and not a summary of contents thereof or be used in the interpretation or construction thereof of the contract.
4. Unless otherwise stated specifically, in this contract documents the singular shall include the plural and vice versa wherever the context so requires. Works implementing persons

shall include relevant corporate companies / registered associations / body of individual / firm of partnership.

5. Notwithstanding the sub-divisions of the documents into separate sections and volumes every part of each shall be supplementary to and complementary of every other part and shall be read with and into the context so far as it may be practicable to do so.
6. Where any portion of the General Conditions of contract is repugnant to or at variance with any provisions of the special conditions of contract, then, unless a different intention appears, the provisions of the special conditions of contract shall be deemed to override the provisions of General conditions of Contract and shall to the extent of such repugnancy or variance prevail.
7. The materials, Design and Workmanship shall satisfy the relevant I.S.S. and Codes referred to. If Additional requirements are shown in the specifications, the same shall be satisfied over and above I.S.S. and Codes.
8. If the specification mention that the contract shall perform certain work or provide certain facilities, it will mean that the contractor shall do so at his own cost.
9. **CONTRACTOR TO OBTAIN HIS OWN INFORMATION :-**

The correctness of the details given in the tender documents is not guaranteed. The contractor shall independently obtain all necessary information for making the tender. The contractor shall be deemed to have examined Contract Documents, to have generally obtained his own information in all matters that might affect the carrying out of the work or the Tenderer rates. Any error in description of quantity or commission there from shall not vitiate the contract or release the contractor from executing the work comprised in the contract according to the Drawings and specifications at the tendered rates. He is deemed to have known the scope, nature and magnitude of the work and the requirements of materials and labour involved and as to what all works he has to complete in accordance with the contract whatsoever be the defects, omissions, or errors that may be found in the contract documents. The contractor shall be deemed to have visited the site and the surroundings, to have satisfied himself to the nature of all existing structures, if any, and also as to the nature and the conditions of railways, roads, bridges and culverts, means of transport and communications, whether by land, air or water and as to possible interceptions thereto and the access and agrees from the site, to have made inquires, examined and satisfied himself as to the sites for obtaining sand, stones, bricks and other materials, the sites for disposal of surplus materials, the available accommodation as to whatever required, the depicts and such other buildings as may be necessary for executing and completing the work, to have local independent inquiries as to the subsoil, subsoil water and variation thereof, storms, prevailing winds, climatic conditions and all other similar matters effecting the work. He is deemed to have acquainted himself as to his liability for payment of Government taxes, custom duty and other charges.

Any neglect or failure on the part of the contractor in obtaining necessary and reliable information upon the forgoing or any other matters affecting the contract shall not relieve him from any risks or liabilities or the entire responsibility from completion of the work at the tendered rates and time in strict accordance with the contract documents.

No verbal agreement or inference from conversation with any officer or employee of the owner either before or after the execution of the Contract Agreement shall in any way effect or modify any of the terms of obligations herein contained.

**GC-06 CONTRACTOR TO UNDERSTAND HIMSELF FULLY ;**

The contractor by tendering shall be deemed to have satisfied himself, as to consideration and circumstances affecting the tender price, as to the possibility of executing the works as shown and described in the contract and to have fixed his prices according to his own view on these matters and to have understand that no additional allowances except as otherwise expressly provided, will after words be made beyond the contract price. The contractor shall be responsible for any misunderstanding or incorrect information given in writing by the Engineer.

**GC-07 ERROR IN SUBMISSION ;**

The contractor shall be responsible for any errors or omissions in the particulars supplied by him. Whether such particulars have been approved by the Engineer or not, provided that such discrepancies, errors or omissions be not due to inaccurate information or particular furnished in writing to the Contractor by the Municipal Corporation or the Engineer.

**GC-08 SUFFICIENCY OF TENDER :**

The Contractor shall be deemed to have satisfied himself before tendering as to the correctness of the tender rates which rates shall, except as or otherwise provided for, cover all the Contractor's liabilities and obligation set further or implied in the contract for the proper execution of work for compliance with requirements of Article GC-19 thereof.

**GC-09 DISCREPANCIES :**

The drawings and specifications are to be considered as mutually explanatory of each other, detailed drawings being followed in preference to small scale drawings and figures dimension in preference to scale and special conditions in preference to general conditions. Special direction or dimensions given in the specifications shall supersede all else. Should any discrepancies however, appear or should any misunderstanding arise as to the meaning and intent of the said specifications or drawings, or as to the dimensions or the quality of the materials or the due and proper execution of the works, or as to the measurement or quality and valuation of the works executed under this contract or as extra there upon the same shall be explained by the Engineer-in-charge and his explanation shall subject to the final decision of the Executive Engineer, in case reference be made to him, be binding upon the contractor shall execute the work according to such explanation (subject to aforesaid) and without addition to or deduction from the contract and shall also do all

such works and things necessary for the proper completion of the works as implied by the Drawings and specifications, even though such works and things are not specially shown and described in said specifications. In cases where not particular specifications are given for any article to be used under the contract, relevant specifications of the Indian Standard Institution shall apply.

**GC-10 PERFORMANCE GUARANTEE : (Security Deposit)**

1. A A sum of 5% of the accepted value of the tender contract price shall be deposited by the tenderer (hereinafter called. The Contractor while tender is accepted) as Security deposit with the BMC for the faithful performance, completion of the works in accordance with the contract documents and to the satisfaction of the Engineer and assuring the payment of all obligations arising from the execution of the contract.

This shall be deposited at 5 % of the value of the contract within ten days of the receipt by him or the notification of acceptance of tender and at least three (3) days before the contract agreement is executed in the forms mentioned below :

(a) In cash or by a demand draft of a Schedule Bank / Nationalized Bank acceptance to owner on the Bhavnagar Branch.

OR

(b) A fixed deposit receipt (FDR) of a Schedule Bank / Nationalized Bank located at Bhavnagar duly endorsed in favour of the Municipal Commissioner, Bhavnagar Municipal Corporation, Bhavnagar.

OR

(c) 5.00% of tender amount shall be acceptable in form of form of Bank Guarantee of any Schedule Bank / Nationalized bank ( en cashable at Bhavnagar) having validity of duration of work plus ninety (90) days.

1 B If the value of the work as per actual execution exceeds the accepted value of tender because of allotment of further work further recoveries towards security deposit shall be effected at five percent (5%) of R. A. Bill to make up the total amount of security deposit equal to five percent (5%) of the revised value of contract. Alternatively the Contractor may at his option deposit the full amount of security deposit as per the revised value of the contract within fifteen days of receipt by him on the notification accepting the tender in the form as aforesaid.

2. If the Contractor, sub - contractor or their employees shall break, deface or destroy any property belonging to the owner or other agency during the execution of the contract, the same shall be made good by the contractor at his own expenses and in default thereof, the Engineer-in-charge may cause the same to be made good by other agencies and recover expenses from the Contractor (for which the certificate of the Engineer-in-charge shall be final). These expenses can be recovered from the security deposit if recover from other sources is not possible. The amount so reduced in security deposit will be made good by deduction from the next R.A. Bill of the Contractor.

3. All compensation or other sums of money payable by the contractor to the owner under terms of this contract may be deducted from or paid by the sale of sufficient part of his security deposit or from any sums which may be due or become due to the contractor by the owner on any account whatsoever and in the event this Security deposit being reduced by reasons of any such deductions or sale of security deposit or part thereof as aforesaid, the Contractor shall within fifteen days thereafter make good them in cash, bank drafts or Government Securities endorsed as aforesaid. No interest shall be payable by the owner for sum deposited as security deposit.
4. The security deposit shall be extendable upto the date as decided by Engineer in accordance with Requirement of contractual obligations under the contract.
5. The security deposit less any amounts due shall be returned to the contractor without any interest after the defects liability period is over and subject to the Engineer-in-charge certifying that no liability attaches to the contractor.
6. The performance guarantee shall be delivered to the Bhavnagar Municipal Corporation within 10 (Ten) days of the notice of award/L.O.I. Security deposit shall be paid in time and if it is paid next fifteen (15) days from the date of LOI then the penalty of 0.065 % per day of the amount of the security deposit shall be recovered from the contractor while receiving the security deposit. It is also clarified that the amount of the security deposit shall be calculated on the basis of contract value and not on the basis of estimated amount put to tender.( see IT – 27)

**GC-11 INSPECTION OF WORK :**

1. The Engineer in charge will have full power and authority to inspect the work at any time wherever in progress either on the site or at the contractor's any other manufacturers workshops or factories wherever situated and the contractor shall afford for Engineer-in-charge every facility and assistance to carry out such inspection.  
Contractor or his authorised representative shall, at all time during the usual working hours and all other times when so notified, remain present to receive orders and instructions, orders given to Contractor's representative shall considered to have the same force as if they had been given to the contractor himself. Contractor shall give not less than 7 days notice in writing to the Engineer-in-charge before covering up or otherwise placing beyond reach of inspection and measuring any work in order that the same may be inspected and measured. In the event of breach of the above, the same shall be recovered at Contractor's expenses for carrying out such inspection or measurement.
2. No material shall be dispatched from contract store on site of work before obtaining approval in writing of the Engineer-in-charge, Contractor shall provide at all time during the progress of work and maintenance period proper means of access with ladders, gangways, etc. and the necessary attendance to move and adopt as directed for inspection or measurement of work by Engineer-in-charge.

**GC-12 DEFECT LIABILITY :**

1. Contractor shall guarantee the work for a period of **24 months** from the date of issue of completion certificate. Any damage or defect that may arise or that may remain undiscovered at the time of issue of completion certificate connected in any way with the equipment or materials supplied by him or in the workmanship be rectified or replaced by contractor at his own expenses as desired by Engineer-in-charge or in default may cause the same to be made good by other agency and deduct expenses of which the certificate of Engineer-in-charge shall be final from any sums that may then or any time thereafter become due to contractor of sale thereof or of a sufficient portion thereof.
2. From the commencement to completion of work contractor shall take full responsibility for the case of the work including all temporary works and in case any damage, loss or injury shall happen to work or any part thereof or to any temporary works from any cause whatsoever and shall at his own cost repair and make good the same so that at completion work shall be in good order and in conformity in every respect with the requirements of contract and as per the instructions of the Engineer-in-charge.
3. If at any time before the work is taken over, the Engineer-in-charge shall -
  - (a) Decide that any work done or materials used by the contractor are defective or not in accordance with contract or that work of any portion thereof is defective or do not fulfill the requirements of contract (all such materials being hereinafter called defects in this clause and (b) as soon as reasonably practicable given to contractor notice in writing of the said defect specifying particulars of the defects alleged to exist or to have occurred, then contractor shall at his own expenses and with all speed make good the defects so specified.
  - (b) In case contractor fails to do so, owner may take at the cost of the contractor, such steps as may in all circumstances, be reasonable to make good such defects. The expenditure so incurred by BMC will be recovered 1.5 times from the amount due to contractor. The decision of Engineer-in-charge with regard to the amount to be recovered from contractor will be final and binding on the contractor.

#### **GC-13 POWER OF ENGINEER TO GIVE FURTHER INSTRUCTIONS :**

The Engineer shall have the power and authority from time to time and at all times to give further instructions and directions as may appear to him necessary or proper for the guidance of contractor and the works and efficient execution of the works according to the terms of the specifications, and the contractor shall receive, execute, obey and be bound by the same, according to the true intent and meaning thereof, as fully and effectually as though the same had accompanied or had been mentioned or referred to in the specifications. No work which radically changes the original nature of the contract shall be ordered by the Engineer and in the event of any deviation being ordered, which in the opinion of the contractor changes the original nature of the contract, the shall nevertheless carry it out and any disagreement as to the nature of the work & the rate to be paid thereof shall be resolved. The time of completion of works, in the event of any deviations, resulting in additional cost over the contract sum being ordered, then be extended

or reduced reasonable by the Engineer. The Engineer's decision in the case shall be final and binding.

**GC-14 PROGRAMME :**

The time allowed for execution of works shall be essence of the contract. The contract period shall commence from date of Notice of intimation to proceed. The tenderer at the time of submitting his tender shall indicate the construction schedule, the month-wise program required for the execution of the works and shall confirm the same within fourteen (14) days of the acceptance of his Tender. The contractor shall provide to the Engineer-in-charge a detailed program of time schedule for execution of the works in accordance with the specifications & the completion date. The entire program to be finalized by the Contractor, has to confirm to the execution period mentioned along with the Bill of Quantities in the Tender Documents. The Engineer upon scrutiny of such submitted program by contractor, shall examine suitability of it to the requirement of contract and suggest modifications, if found necessary.

**GC-15 SUBLETTING OF WORKS :**

No part of the contract nor any share or interest thereon shall in any manner or degree be transferred, assigned or sublet by the contractor directly or indirectly to any firm or Corporation whatsoever except as provided for in the succeeding subclause without the consent in writing of the owner.

**GC-16 SUB-CONTRACTORS FOR TEMPORARY WORKS ETC. :**

The owner may give written consent to sub-contractors for execution of any part of the work at the site being entered upon by the contractors provided each individuals contractor is submitted to the Engineer-in-charge before being entered into and in approved by him. List of Sub-Contractors is to be supplied. Not with standing any subletting with such approval as aforesaid and notwithstanding the Engineer-in-charge shall have received copies of any sub-contractors, the contractors shall be and shall remain solely responsible for the quality and proper expeditions and execution of the works and the performance of all the conditions of contract in all respects as if such submitting or sub-contracting had not taken place and as if such work had done directly by the Contractor.

**GC-17 TIME FOR COMPLETION:**

1. The work covered under this contract shall be commenced from the date of contractor is served with a notice to proceed with the work and shall be completed before the date as mentioned in the time schedule of work. The time is the essence of the contract and unless the same is extended as mentioned in clause No. GC-18 (Extension of time) the contractor will be panelized for the delay.
2. The general time schedule for construction is given in the tender document. Contractor shall prepare a detailed weekly or monthly construction program in consultation with Engineer-in-charge soon after the agreement and the work shall be strictly executed accordingly. The time

for construction given includes, the time required for testing, rectification if any, retesting and completion in all respects to the entire satisfaction of the Engineer-in-charge.

**GC-18 EXTENSION OF TIME :**

Time shall be considered as the essence of the contract. If however, the failure of the Contractor to complete the work as per the stipulated dates referred to above arises from delays on the part of Municipal Corporation in supplying the materials of equipment it has undertaken to supply under the contract or from delays in handing over sites or from increase in the quantity of work to be done under the contract, or force Majeure an appropriate extension of time will be given. The Contractor shall request such extension within one month of the cause of such delay and in any case before expiry of the contract period.

**GC-19 CONTRACT AGREEMENT :**

The successful tenderer shall when called upon to do so, enter into and execute the Contract Agreement within (15) Fifteen days from the Notice of Award, in the form shown in tender documents with such modifications as may be necessary in the opinion of the Municipal Commissioner. It should be incumbent on the contractor to pay the stamp duty and the legal charges for the completion of the contract agreement.

**GC-20 A. PENALTY FOR DELAY/LIQUIDATED DAMAGES:**

If the contractor fails to complete the work within the stipulated completion date for the work or Amount retain at One tenth of one percent of contract value for that particular time period, per day of delay in completion of work or part thereof as the case may be. The amount of retention shall, however, be subjected to a maximum of ten (10) percent of the contract value.

Moreover he shall pay liquidated damages at One tenth of one percent of contract value per day of delay in completion and handing over the work or part thereof as the case may to the Municipal Commissioner. The amount of liquidated damages shall, however, be subjected to a maximum of ten (10) percent of the contract value.

Delays in excess of one hundred days will be a cause for termination of the contract and forfeiture of all security for performance. In case of contractor achieves total target of progress in next quarter , BMC will release the amount recovered in previous quarter.

**B. BAR CHART:**

The successful tenderer shall have to submit the progress bar-chart within fifteen days after the contract, and the contractor should work as per the approved bar-chart, failing the contractor shall have to pay the compensation for delay as per the decision of Municipal Commissioner.

**GC-21 FORFEITURE OF SECURITY DEPOSIT :**

Whenever any claim arises against the contractor for the payment of a sum of money out of or under the contract, the owner shall be entitled to recover such sum by appropriating in part or



whole, the security deposit of the contractor. In case the Security deposit is insufficient the balance recoverable shall be deducted from any sum then due or which at any time thereafter may become due to the contractor shall pay to the owner on demand may balance remaining due.

**GC-22 ACTION OF FORFEITURE OF SECURITY DEPOSIT :**

In any case in which under any clause or clauses of the contract, the contractor shall have forfeited the whole of his Security deposit or have committed a breach of any of the terms contained in this contract, the owner shall have power to adopt any of the following courses as he may deem best suited to his interest -

- (a) To rescind the contract (of which rescission notice in writing to the contractor under the hand of the owner shall be conclusive evidence) in which case, the security deposit of the contractor shall stand forfeited and be absolutely at the disposal of the owner.
  
- (b) To employ labour and to supply materials to carry out the balance work debiting contractor with the cost of labour employed and the cost of materials supplied for which a certificate of the Engineer-in-charge shall be final and conclusive against the contractor and 10% costs on above to cover all departmental charges and crediting him with the value of work done at the same rates as if it has been carried out by the contractor under the terms of his contract. The certificate of Engineer-in-charge as to the value of the work done shall be final and conclusive against the contractor.
  
- (c) To measure up the work of the contractor and to take such part hereof as shall be unexecuted out of his hand to give it to another contractor to complete. In this case the excess-expenditure incurred than what whole have been paid to the original contractor, if the said work had been executed by him, shall be earnest and paid by the original contractor and shall be deducted from any money due to him by the owner under the contract or otherwise and for the excess expenditure, the certificate of the Engineer-in-charge shall be final and conclusive.

In the event any of the above course being adopted by the owner, the contractor shall have no claim to compensation for any loss sustained by him by reason of his having purchased or procured any materials or entered into any agreement so or made by advance on account of or with a view to the execution of the work of the performance of the contract. In such case the contractor shall not be entitled to recover or be paid by sum for any work actually performed under this contract unless the Engineer-in-charge will certify in writing the performance of such work and the value payable in respect thereof and the shall only be entitled to be paid the value so certified. In the event of the owner putting in force the powers as stated in a, b, c, above vested in him under the preceding clause, he may, if he so desire, take possession of all or any tools and plant, materials and stores in or upon the work or the site thereof belonging to the contractor, or procured by him and intended to be used for the execution of the work or any part thereof paying or allowing for the same in account at the contract rates to be certified by the Engineer-in-charge whose certificate thereof shall be final otherwise the Engineer-in-charge may give notice in writing to the contractor or his representative requiring him to remove such tools plant materials or stores from the premises within the time specified in the notice and in if the contractor fails to comply with any such notice, the Engineer-in-charge may remove them at the Contractor's expenses or sell them by

auction or private sale on account of the contractor and his risks in all respects without any further notice as to the date, time to place of the sale and the certificate of Engineer-in-charge as to the expenses of any such removal and the amount of the proceeds and the expenses of any such sale shall be final and conclusive against the contractor.

**GC-23 NO COMPENSATION FOR ALTERATION IN OR RESTRICTION OF WORK :**

If at any time from the commencement of work, the owner shall for any reasons whatsoever not require the whole or part thereof as specified in the tender to be carried out, the Engineer-in-charge shall give notice in writing to the contractor, who shall have no claim to any payment or compensation whatsoever on account of any profit or advantage which he might have derived from execution of work in full, but which he did not derive in consequence of the full amount of the work not having been carried neither shall have any claim for compensation by reason if any alternations having been made in original specifications, drawings, designs and instructions which shall involve any curtailment of the work as originally contemplated.

When the contractor is a partnership firm, the prior approval in writing of the BMC shall be obtained before any change is made in the constitution of the firm, where the contractor is an individual or a Hindu Undivided Family business concern, such approval as aforesaid shall, likewise be obtained before sub-contractor enters into any agreement with other parties where under the reconstituted firm would have the right to carry out the work hereby undertaken by the contractor. In either case if prior approval as aforesaid is not obtained, the contract shall be deemed to have been allotted in contravention of subletting clause hereof and the same action may be taken and the same consequence shall ensure as provided in the subletting clause.

**GC-24 IN EVENT OF DEATH OF CONTRACTOR :**

Without prejudice to any of the right or remedies under the contract, if the contractor dies, the owner shall have the option of terminating the contract without compensation to the contractor.

**GC-25 MEMBER OF THE OWNER NOT INDIVIDUALLY LIABLE :**

No official or employee of the owner shall in any way be personally bound or liable for the acts or obligations of the owner under the contract or answerable for any default or omission in the observance or performance of the acts, matters or things which are herein contained.

**GC-26 OWNER NOT BOUND BY PERSONAL REPRESENTATIONS :**

The contractor shall not be entitled to any increase on the Schedule of rates or any other rights or claims whatsoever by reason of representation, explanation or statement or alleged representation, promise or guarantees given or alleged to have been given to him by any person.

**GC-27 CONTRACTOR'S OFFICE AT SITE :**

The Contractor shall provide and maintain an office at the site for the accommodation of his agent and staff and such office shall be opened at all reasonable hours to receive instructions, notice or other communications.

**GC-28 CONTRACTOR'S SUBORDINATE STAFF AND THEIR CONDUCT :**

1. The contractor on award of the work shall name and depute a qualified Engineer, having experience of carrying out work of similar nature, to whom equipments, materials, if, any, shall be issued and instructions for work given. The contractor shall also provide to the satisfaction of Engineer in-charge sufficient and qualified staff to superintend the execution of the work, competent sub-agents, foremen and leading hands including those specially qualified by previous expeditions to supervise the type of works comprised in the contract in such manner as will ensure work of the best quality and expeditions working, it, in the opinion of the Engineer-in-charge, additional properly qualified supervision staff is considered necessary, if shall be employed by the contractor without additional charge on account thereof. The contractor shall ensure to the satisfaction of the Engineer- in-charge that sub-contractors, it any shall provide competent and efficient supervision over the work entrusted to them.
2. If and whenever any of the contractor's or sub-contractor agents, sub-agents, assistance, Forman or other employees shall, in the opinion of Engineer-in-charge, be guilty of any misconduct or be incompetent or insufficiently qualified or intelligent in the performance of their duties or that in opinion of the owner or Engineer-in-charge, it is undesirable for administrative or any other reason for person or persons to be employed in the works, the contractor, if so directed by the Engineer-in-charge, shall at once remove person or persons from employment thereon. Any person or persons so removed shall not again be reemployed in connection with the works without the written permission of the Engineer-in-charge. Any person so removed from the works shall be immediately replaced at the expenses of the contractor by qualified and competent substitute. Should the contractor be required to repatriate any person removed from the works he shall do so and shall bear all costs in connection therewith.
3. The contractor shall be responsible for the proper behavior of all the staff, foremen, workmen and others shall exercise proper control over them and in particular and without prejudice to the same. Generally, the contractor shall be bound to prohibit, and prevent any employee from trespassing or acting in any way detrimental or prejudicial to the interest of the community or of the properties or occupiers of land and properties in the neighborhood and in the event of such employees so trespassing, the contractor shall be responsible therefore and relieve the owner of all consequent claims, actions for damages or injury or any other grounds whatsoever. The decision of the Engineer-in-charge upon any matter arising under this clause shall be final.
4. If and required by the owner, the contractor's personnel entering upon the owner's premises shall be properly identified by badges of a type acceptable to the BMC which must be worn at all times on owner's premises.

**GC-29 TERMINATION OF SUB-CONTRACTOR BY OWNER :**

If any sub-contractor engaged upon the works at the site executes any work which in the opinion of Engineer-in-charge is not in accordance with the contract documents, the BMC may be give written notice to the contractor request his to terminate such sub-contract and the contractor upon the receipt of such notice shall terminate such sub-contract and the letter shall forthwith leave the works failing which the owner shall have the right to remove such sub-contractors from the site.

No action taken by the owner under the above clause shall relieve the contractor of his liabilities under the contract or give rise to any right to compensation, extension of time or otherwise.

**GC-30 POWER OF ENTRY :**

If the contractor shall not commence the work in the manner previously described in the contract documents or if he shall, at any time, in the opinion of Engineer-in-charge.

- (i) Fail to carry out works in conformity with the documents or
- (ii) Fail to carry out the works in accordance with the time schedule.
- (iii) Substantially suspend work or the works for a period of fourteen days without authority from Engineer-in-charge or
- (iv) Fail to carry out and execute the work to the satisfaction of the Engineer-in-charge or
- (v) Fail to supply sufficient or suitable construction plant temporary works, labour materials or things or
- (vi) Commit breach of any other provisions of the contract on his part to be performed or observed or persist in any of the above mentioned breached of the contract for fourteen days after notice in writing shall have been given to the contractor by the Engineer-in-charge requiring such breach to be remedied or
- (vii) Abandon the work or
- (viii) During the continuance of the contract becomes bankrupt, make any arrangement or compromise with his creditors, or permit any execution to be levied or go into liquidation whether compulsory or voluntary not being merely a voluntary liquidation for the purpose of amalgamation or reconstruction then in any such case.

The owner shall have the power to enter upon the works and take possession thereof and of the materials, temporary works, constructional plant and stock therein, and to revoke the contractor's license to use the same and to complete the works by his agents, other contractor or workman or to re- let the same upon any terms and to such other person, firm or corporation as the owner in his absolute discretion may think proper to employ, and for the purpose aforesaid to use or authorise the use of any materials, temporary works, constructional plant, and stock as aforesaid, without making payment or allowance to the Contractor for the said materials other than such as may be certified in written by the Engineer-in-charge to be reasonable and without making any payment or allowance to the contractor for the use of said temporary works, constructional plant and stock or being liable for any less or damage thereto. If the owner shall have reason of his taking possession of the works or of the work being got completed by other contractor incur excess certified by the Engineer-in-charge shall be deducted from any money which may be due for the

work done by the contractor under the contract and not paid for. Any deficiency shall forthwith be made good and paid to the owner by the contractor and the owner shall have power to sell in such manner and for such price as he may think fit all or any of the constructional plant, materials etc. constructed by or belonging to and recoup and retain the said deficiency or any part thereof out of the proceeds of the sale.

**GC-31 CONTRACTOR'S RESPONSIBILITY WITH THE OTHER CONTRACTOR & AGENCIES:**

Without repugnance to any other condition, it shall be the responsibility of the contractor executing the work of civil construction to work in close co-operation and co-ordinate the work with other contractors or their authorized representative and the contractor will put a joint scheme with the concurrence of other contractors showing the arrangements for carrying his portion of the work to the Engineer-in-charge and get the approval. The Engineer-in-charge before approving the joint scheme will call the parties concerned and modify the scheme if required. No claim will be entertained on account of the above. The contractor shall conform in all respects with the provisions of any statutory regulations, ordinances or by laws of any local or locally constituted authorities or public bodies which may be applicable from time to time to works or any temporary works. The contractor shall keep the owner indemnified against all penalties and liabilities of every kind arising out of non-adherence to such statutes, ordinance, laws, rules, regulations, etc.

**GC-32 OTHER AGENCIES AT SITE :**

The Contractor shall have to execute the work in such place and condition where other agencies will also be engaged for other works, such as site grading, filling and leveling, electrical and mechanical engineering works, etc. No claim shall be entertained for works being executed in the above circumstances.

**GC-33 NOTICES :**

Any notice under this contract may be served on the contractor or his duly authorized representative at the job site or may be served by registered post direct to the official address of the contractor proof of issue of any such notice could be conclusive of the contractor having been duly informed of all contents therein.

**GC-34 RIGHT OF VARIOUS INTERESTS :**

The owner reserves the right to distribute the work between more than one contractor. Contractor shall co-operate and afford reasonable opportunity to other contractors for access to the works for the carriage and storage of materials and execution of their works.

Wherever the work being done by any department of the owner or by other contractor employed by the owner is contingent upon work covered by this contract, the respective rights of the various interests shall be determined by Engineer-in-charge to secure the completion of various portions of the work in general harmony.

**GC-35 PRICE ADJUSTMENT :**

No adjustment or variation or enhance rate on any ground in price shall be allowed

**GC-36 TERMS OF PAYMENT :**

The payment of Bills shall be made progressively according to the rules and practice followed by the Municipal Corporation. The progressive payment unless otherwise provided in the Contract Agreement or subsequently agreed to by the parties, shall be made generally monthly on submission of a bill by the Contractor in prescribed form in an amount according to the value of the work performed less the aggregate of previous progressive payments and as required by clause GC-37 (Retention money) herein. All such progressive payment shall be regarded as payment by way of advance against final payment.

Payment for the work done by the contractor will be based on the measurement at various stages of the work, in accordance with the conditions at Clause GC-78 (Measurement of Work in Progress)

**GC-37 RETENTION MONEY :**

Pursuant to Clause GC-36 Terms of Payment) on all money due to the contractor for work done, Municipal Corporation will hold as retention money of Five percent (5%) of the value of work. The retention money will not normally be due for payment until the completion of the entire work and till such period the work has been finally accepted by the Municipal Corporation and completion certificate issued by the Municipal Corporation in pursuant to Clause No.GC-84 (Completion Certificate).

However, after the issuance of completion certificate, and Municipal Commissioner may at its own discretion and having considered the Contractor's performance and diligence during the contract time allow the retention money to converted into a Bond as stipulated in the Clause GC-10 (Performance Bond Security Deposit).

**GC-38 PAYMENT DUE FROM THE CONTRACTOR :**

All costs, damages or expenses, for which under the Contract the Contractor is liable to the Municipal Corporation deducted by the Municipal Corporation from any money due or becoming due to the Contractor under the contract or from any other contract with the Municipal Corporation or may be recovered by action at law or other-wise from the Contractor.

**GC-39 CONTINGENT FEE :**

1. The Contractor warrants that he has not employed any person to solicit or secure the contract upon any agreement for a commission, percentage, brokerage or contingent fee. Breach of this warranty shall give the Municipal Commissioner the right to cancel the contract or to take any other measure as the Municipal Commissioner may deem fit. The warranty does not apply

to commissions payable by the contractor to establish commercial or selling agent for the purpose of securing business.

2. No officer, employer of the Municipal Corporation be admitted to any share or part of this contract or to any benefit that may rise therefrom.

#### **GC-40 BREACH OF CONTRACT BY CONTRACTOR :**

If the contractor fails to perform the work under the contract with due diligence or shall refuse or neglect to comply with instruction given to him by the Engineer-in-charge in accordance with the contract, or shall contravene the provisions of the contract, the BMC may give notice in writing to the contractor to make good such failure, neglect or contravention. Should the Contractor fail to comply with such written notice within twenty eight (28) days of receipt, if the Municipal Commissioner shall think fit, it shall be lawful for the Municipal Corporation, without prejudice to any other rights, the contractor may have under the contract, to terminate the contract for all or part of the works, and to make any other arrangements it shall deem necessary to complete the work outstanding under the contract at the time of termination. In this event Article GC-15 (Subletting of work) and GC-16 (Sub-Contracts for Temporary Works etc.) hereof shall be invoked and the performance Bond shall immediately become due and payable to the Municipal Commissioner. The value of the work done on the date of termination and not paid for shall stand forfeited to the Municipal Corporation and the Municipal Corporation shall have free use of any works which the contractor may have at the site at the time of termination of the contract.

#### **GC-41 DEFAULT OF CONTRACTOR :**

1. The Municipal Corporation may upon written notice of default to the contractor terminate the contract in circumstance detailed hereunder :
  - (a) If in the judgement of the Municipal Corporation the contractor fails to make completion of works within the time specified in the completion schedule or within the period for which extension has been granted by the Municipal Corporation/Engineer to the Contractor.
  - (b) If in the judgement of the Municipal Corporation the contractor fails to comply with any of the provisions of this contract.
2. In the event the Municipal Commissioner terminates the contract in whole or in part as provided in Article GC-49 (Termination of Contract), the Municipal Corporation reserves the right to purchase upon such terms and in such manner as it may deem appropriate, plant similar to that terminated and the contractor will be liable to the Municipal Corporation for any additional costs for such similar and / or for liquidated damages for delay until such reasonable time as may be required for the final completion of works.
3. If this contract is terminated as provided in this paragraph GC - 30 (Power of entry) (1) the Municipal Corporation in addition to any other rights provided in this clause, may require the Contractor to transfer title and deliver to the Municipal Corporation under any of the following cases in the manual and as directed by the Municipal Corporation.

- (a) Any partially completed performance and contract rights as the contractor has specifically produced or acquired for the performance of the contract so terminated.
- (4) In the event the Municipal Corporation does not terminate the contract as provided in the paragraph GC-49 (Termination of Contract) the Contractor shall continue performance of the contract, in which case he shall be liable to the Municipal Corporation for liquidated damages for delay until the works are accepted.

**GC-42 BANKRUPTCY :**

If the Contractor shall become bankrupt or insolvent or have a receiving order made against him, or compound with the creditors, or being the Municipal Corporation commence to be wound up, not being a member's Voluntary winding up for the purpose of amalgamation or reconstruction, or carry on its business under a receiver for the benefit of his creditors or any of them, the owner shall be at liberty to either (a) terminate the contract forthwith by giving notice in writing to the contractor or to the receiver or liquidator or to any person or organization in whom the contract may become vested and to act in the manner provided in Article GC-41 (Default of Contractor) as though the last mentioned notice had been the notice referred to in such Article of (b) to give such receiver liquidator or other person in work the contract may become vested the option of carrying out the contract subject to his providing a satisfactory guarantee for the due and faithful performance of the contract upto an amount to be agreed. In the event that the Municipal Corporation terminates the Contract in accordance with this article, the performance Bond shall immediately become due and payable on demand to Municipal Corporation.

**GC-43 OWNERSHIP :**

Works supplied pursuant to the Contract shall become the property of the Municipal Corporation from whichever is the earlier of the following times, namely,

- (a) When the works are completed pursuant to the Contract.
- (b) When the Contractor has been paid any sum to which he may become entitled in respect thereof pursuant to clause GC-36 (Terms of Payment).

**GC-44 DECLARATION AGAINST WAIVER :**

The condonation by the Municipal Corporation of any breach or breaches by the stipulations and conditions contained in the contract shall in no way prejudice or effect to the construed as a waiver of the Municipal Corporation rights, powers and remedies under the contract in respect of any breach or breaches.

**GC-45 LAWS GOVERNING THE CONTRACT :**

The contract shall be constituted according to and Subject to the laws of India and the State of Gujarat and under the jurisdiction of the courts of Gujarat at Bhavnagar.

**GC-46 OVERPAYMENT AND UNDERPAYMENT :**



Whenever any claim for the payment of a sum to the Municipal Corporation arises out of or under this Contract against the contractor the same may be deducted by the Municipal Corporation from any sum then due or which at any time thereafter may become due to the contractor under this contract and failing that under any other contract with the Municipal Corporation or from any sum due to the contractor with the Municipal Corporation (which may be available with Municipal Corporation), or from his retention money, or he shall pay the claim on demand. The Municipal Corporation reserves the right to carry out post payment audit and technical examination of the final bill including all supporting vouchers, abstracts, etc.

The Municipal Corporation further reserves the right to enforce recovery of any over payment when detected notwithstanding the fact that the amount of the final bill may be included by one of the parties as an item of dispute and notwithstanding the fact that the amount of the final bill figure will be decided by appropriate authority.

If as a result of such audit and technical examination any over payment is discovered in respect of any work done by the Contractor or alleged to have been done by him under the contract, it shall be recovered by the Municipal Corporation from the contractor by way of all the means prescribed above.

if any under payment is discovered by the Municipal Corporation, any amount due to the contractor under this contract or under payment may be adjusted against any amount or which may at any time thereafter become due before payment is made to the contractor shall be paid to Contractor by the Municipal Corporation on any other contract account whatsoever.

**GC-47 SETTLEMENT OF DISPUTES :**

Except or otherwise specifically provided in the contract, all disputes concerning questions of fact arising under the contract shall be decided by the Engineer, subject to a written appeal by the Contractor to the Engineer, and these decisions shall be final and binding on the parties hereto. Any disputes or difference including those considered as such by only one of the parties arising out of or in connection with this contract shall be to the extent possible settled amicably between the parties.

**GC-48 DISPUTES OF DIFFERENCE TO BE REFERRED TO :**

Disputes if any, shall be discussed and mutually settled as per GC-47 and in case of disagreement the same shall be referred to Commissioner/Standing Committee. After referring to Commissioner / Standing Committee if the said dispute is not solved, the same shall be referred to the court subject to Bhavnagar Jurisdiction only.

**GC-49 TERMINATION OF THE CONTRACT :**

1. If the Contractor finds it impracticable to continue operation owing to Force Majeure reasons or for any reason beyond his control and/or the Municipal Commissioner finds it impossible to continue operation then prompt notification in writing shall be given by the party affected to the other.

2. If the delay or difficulties so caused can not be expected to cease or become unavoidable or if operations can not be resumed within six (6) months the party shall have the right to terminate the contract upon Ten (10) days written notice to the other. In the event of such termination of the contract, payment to the Contractor will be made as follows :
  - a) The Contractor shall be paid for all works approved by the Engineer and for any other legitimate expenses due to him.
  - b) If the Municipal Commissioner terminates the contract owing to Force Majeure or due to any cause beyond its control, the contractor shall additionally be paid for any work done during the said Six (6) months period including any financial commitment made for the proper performance of the Contract and which are not reasonable defrayed by payment under (a) above;
  - c) The Municipal Commissioner also release all bonds and guarantees at its disposal except there is cause where the total amount of payments made to the contractor exceeds the final amount due to him in which case the contractor shall refund the excess amount within Sixty (60) days after termination and the Municipal Commissioner thereafter shall release all bonds and guarantees, should the contractor fail to refund the amount received in excess within the said period such amounts shall be deducted from the bonds or guarantees provided.
3. On the termination of the contract for any cause the contractor shall see the orderly suspension and termination of operations, with due consideration to the interests of the Municipal Corporation with respect to completion, safeguarding or storing of materials procured for the performance of the contract and the salvage and resale thereof.

**GC-50 CHANGES IN CONSTITUTION :**

Where the contractor is a partnership firm, the prior approval in writing of the Municipal Commissioner shall be obtained if any change is made in the constitution of the firm. Where the contractor is an individual or an undivided family business concern such approval as aforesaid shall like wise be obtained before the contractor enters into any partnership agreement where under the partnership firm would have the right to carry out the works hereby undertaken by the contractor. If prior approval as aforesaid is not obtained the contract shall be deemed to have been assigned in contravention of Article thereof.

**GC-51 SUB-CONTRACTUAL RELATIONS :**

Shall be modified and read as under :-

“Sub contracting / Sub-letting the work is prohibited under this contract“

**GC-52 LIEN :**

If, at any time, there should be evidence of any lien or claim for which owner might have become liable and which is chargeable to the contractor, the owner shall have the right to retain out of any payment then due or thereafter to become due an amount sufficient to completely indemnify the owner against such lien or claim or if such lien or claim be valid the owner may be or become due and payable to the contractor. If any lien or claims remaining, unsettled after all payments are made, the contractor shall refund or pay to the owner all money that the later may be compelled to pay in discharging such lien or claim including all cost and reasonable expenses.

**GC-53 EXECUTION OF WORK :**

The whole work shall be carried out in strict conformity with the provisions of the Contract Documents, detailed drawings, specifications and the instructions of the Engineer-in-charge from time to time. The Contractor shall ensure that the whole work is executed in the most substantial, proper and best workmanship using materials of best quality in strict accordance with the specifications to the entire satisfaction of the Engineer-in-charge.

**GC-54 WORK IN MONSOON :**

When the work continues in monsoon if so desired by Engineer-in-charge, the contractor shall maintain minimum labour force required, for the work and plan and execute the construction and erection work according to the prescribed schedule. No extra rate will be considered for such work in monsoon. During monsoon and entire constructing period the contractor shall keep the site free from water at his own cost.

**GC-55 WORK CLOSED ON SUNDAYS & HOLIDAYS AND BETWEEN SUNSET AND SUNRISE:**

No work shall be carried out on Sundays and Corporation Holidays and no work shall be carried out between sunset and sunrise. Except with the special permission of Engineer-in-charge in writing previously obtained and with holding such permissions shall be no ground of complaint on the part of contractor or cause for compensation to them. Working period shall be maximum eight (8) hours per days.

**GC-56 EXTRA SUPERVISION CHARGES TO BE BORNE BY CONTRACTOR:**

Further to clause No. GC-55 when Engineer-in-charge feels necessary to give permission to contractor for carrying out work for period of more than Eight hours working period in a day and/or to continue work on Sunday and Corporation holidays. Extra Supervision charges arising due to overtime working of Corporation's staff shall be borne by the contractor at prevailing rates from time to time. Such extra supervision charges shall be deducted by Corporation from the running bill/s of the contractor at Bhavnagar Municipal Corporation's description.

**GC-57 DRAWING TO BE SUPPLIED BY THE OWNER :**

The drawings attached with the tender documents shall be for general guidance of the contractor to enable him to visualise the type of work contemplated and scope of work involved. Detailed working drawings according to which the work is to be done shall be furnished from time to time

as the work progresses. The contractor shall study the drawings thoroughly in connection with other connected details and discrepancy if any bring to the notice of the Engineer-in-charge before actually carrying out the work. Contractor should make demand for drawing prior 15 days.

**GC-58 DRAWINGS TO BE SUPPLIED BY THE CONTRACTOR :**

Where drawings are to be furnished by the contractor they shall be as enumerated in special condition of contract and shall be furnished within the specified time. Where approval of drawings has been specified it shall be the Contractor's responsibility to have these drawings got approved before any work is taken up with regard to the same. Any changes becoming necessary in these drawings during the execution of the work shall have to be carried out by the contractor at no extra cost. All final drawings shall bear the certification stamp as indicated below duly signed by both the contractor and Engineer-in-charge.

" Certified true for  
\_\_\_\_\_project  
Agreement No. \_\_\_\_\_  
Signed \_\_\_\_\_  
Contractor                      Engineer-in-charge

Drawings will be approved within three (3) weeks of the receipt of the same by the Engineer-in-charge.

**GC-59 SETTING OUT WORK :**

The contractor shall set out the work on the site handed by the Engineer-in-charge and shall be responsible for the correctness of the same. The work shall be carried out to the entire satisfaction of Engineer-in-charge. The approval thereof or taking part by Engineer-in-charge in setting out work shall not relieve contractor of any of his responsibilities.

The contractor shall provide at his own cost all necessary level posts, pegs, bamboo, flag, ranging, rods, strings and other materials and labourers required for proper setting out of the work. The Contractor shall provide, fix and be responsible for the maintenance of all stakes, temples level marks profiles and similar other things and shall take necessary precautions to prevent their removal or disturbance and shall be responsible for the consequence for such removal or disturbance. The contractor shall also be responsible for the maintenance of all existing Survey Marks, Boundary Marks, Distance Marks and Centre line marks either existing or fixed by the Contractor. The Centre, longitudinal or face lines and cross lines shall be marked by small masonry pillars. Each pillar shall have distance mark at the centre for setting up the theodolite. The work shall not be started unless the setting out is checked by Engineer-in-charge in writing but such approval shall not relieve the contractor of his responsibilities. The contractor shall provide all materials, labour and other facilities necessary for checking at his own cost.

Pillars bearing geodetic marks on site shall be protected by the Contractor. On completion of the work the contractor shall submit the Geodetic documents according to which the work has been carried out.

**GC-60 RESPONSIBILITIES OF CONTRACTOR FOR CORRECTNESS OF WORK:**

The contractor shall be entirely and exclusively responsible for the correctness of every part of the work and shall rectify completely and errors thereon at his own cost when so instructed by Engineer-in-charge.

1. Materials to be supplied by Contractor :

Contractor shall procure and provide all the materials required for the execution and maintenance of work including M.S. rods, all tools, tackle, construction plant and equipment except the materials to be supplied by the owner detailed in the contract documents and for the transport thereof, owner, shall make recommendations to the respective authorities if desired by the contractor but assumes no responsibility or any nature. Owner shall insist for procurement of materials with ISI Marks supplied by reputed firms on the DGS& D List.

2. If however the Engineer-in-charge feels that work is likely to be delayed due to contractor's inability to procure the materials, the Engineer-in-charge shall have the right to procure materials from the market and the contractor will accept these materials at the rates decided by Engineer-in-charge

**GC-61 MATERIALS TO BE SUPPLIED BY THE OWNER : (NA)**

1. If the contract provides certain materials or stores to be supplied by the BMC such materials and stores shall be transported by the contractor at his cost from BMC's stores or Railway Station. The sum due from contractor for the value of materials supplied by the owner will be recovered from the R.A.Bill on the basis of actual consumption of materials in the work covered and for which R.A.Bill has been prepared. After completion of the work contractor has to account for the full quantity of materials supplied to him.
2. The value of store materials supplied by the BMC to the contractor shall be charged at rates shown in the contract document and in case any other material not listed in the schedule of materials is supplied by the BMC, the same shall be charged at cost price including carting and other expenses incurred in procuring the same. All materials so supplied shall remain the property of the owner and shall not be removed from the site on any account. Any material remaining un-used at the time of completion of work or termination of contract shall be returned to BMC's store or any other place as directed by the Engineer-in-charge in perfectly good condition at contractor's cost. When materials are issued/ supplied free of cost for us in work and surplus and unaccounted balances thereof are not returned to the Municipal Corporation, recovery in respect of such balance will be effected at double the applicable issue rate of the materials or the market rate whichever is higher.

**GC-62 CONDITIONS OF ISSUE OF MATERIALS BY THE BMC: ( Not Applicable)**

- a) The materials specified to be issued by the BMC to the contractor shall be issued by the BMC's store or at Railway Station and all expenses for its shifting to site shall be borne by the contractor. The materials will be issued during working hours and as per rules of BMC from time to time.
- b) Contractor shall bear all expenses for storage and safe custody at site of materials issued to him before use in work.
- c) Material shall be issued by the BMC in Standard/non-standard sizes as obtained from manufacturer.
- d) Contractor shall construct suitable godowns at site for storing the materials to protect the same from damage due to rain, dampness, fires, theft etc.
- e) The contractor should take the delivery of the materials issued by the BMC after satisfying himself that they are in good conditions. Once the materials are issued, it will be the responsibility of the Contractor to keep them in good condition and in safe custody. If the materials get damaged or if they are stolen, it shall be the responsibility of the contractor to replace them at his cost according to the instructions of the Engineer-in-charge.
- f) For delay in supply or for non supply of materials to be supplied by the BMC, on account of natural calamities, act of enemies, other difficulties beyond the control of the BMC, the BMC carries non-responsibilities. In no case the contractor shall be entitled to claim any compensation for loss suffered by him on this account.
- g) None of the materials issued to the contractor, shall be used by the Contractor for manufacturing items which can be obtained from manufacturer. The materials issued by the owner shall be used for the work only and no other purpose.
- h) Contractor shall be required to execute indemnity bond in the prescribed form for the same custody and account of materials issued by the owner.
- i) Contractor shall furnish sufficiently in advance a Statement of his requirements of quantities of materials to be supplied by the BMC and the time when the same will be required for the work, so as to enable Engineer-in-charge to make arrangements to procure and supply the materials.
- j) A daily account of materials issued by the owner shall be maintained by the Contractor showing receipt, consumption and balance in hand in the form laid down by Engineer-in-charge with all connected paper and shall be always available for inspection in the site office.
- k) Contractor shall see that only the required quantities of materials are got issued and no more. The contractor shall be responsible to return the surplus materials at BMC's store at his own cost.

**GC-63 MATERIALS PROCURED WITH ASSISTANCE OF THE OWNER :**

Notwithstanding anything contained to the contrary in any of the clauses of this contract, where any materials for the execution of the contract are procured with the assistance of the BMC either by issue from BMC stock or purchase made under orders or permits or licenses issued by the Government, the contractor shall hold the same materials as trustees for owner and use such materials economically and solely for the purpose of contract and not dispose them off without the permission of BMC and return, if required by Engineer-in-charge, all surplus or unserviceable materials that may be left with him after the completion of the contract or at its termination for any reason whatsoever on his being paid or credited such prices as Engineer-in-charge shall determine having due regard to the conditions of the materials. The price allowed to contractor shall not exceed the amount charged to him excluding the storage charges if any. The decision of Engineer-in-charge shall be final and conclusive in such matters. In the event of breach of the aforesaid condition, the contractor shall in terms of license of permits and/or for criminal breach of trust be liable to compensate BMC at double rate or any higher rates. In the event of these materials at that time having higher rate or not being available in the market then any other rate to be determined by the Engineer-in-charge and his decision shall be final and conclusive.

**GC-64 MATERIALS OBTAINED FROM DISMANTLING :**

If the contractor, in the course of execution of work is called upon to dismantle any part for reasons other than on account of bad or imperfect work, the materials obtained from dismantling will be the property of the BMC and will be disposed of as per instruction of Engineer-in-charge in the best interest of the BMC

**GC-65 ARTICLE OF VALUE OR TREASURE FOUND DURING CONSTRUCTION:**

All gold, silver and other minerals of any description and all precious stones, coins, treasures, relics, antiques and other similar things which shall be found in under or upon site shall be the property of the owner and the contractor shall property preserve the same to the satisfaction of Engineer-in-charge and shall hand over the same to the owner.

**GC-66 DISCREPANCIES BETWEEN INSTRUCTIONS :**

If there is any discrepancy between the various stipulations of the contract documents of instructions to the contractor or his authorised representative or if any doubt arises as in the meaning of such stipulation or instructions, the contractor shall immediately refer in writing to the Engineer-in-charge whose decision shall be final and conclusive and no claim for losses caused by such discrepancy, shall in any event be admissible.

Incase there is any discrepancy in measurements shown in drawing and specifications, the same shown in drawing shall be considered as final and will be binding upon the contractor.

**GC-67 SCHEDULE OF QUANTITIES AND EXTRA ITEMS :**

**A. Schedule of Quantities :**

Variations in the quantities of work in schedule of quantities shall not vitiate the contract. Quantities shown in the tender are approximate and no claim shall be entertained for quantities of work executed being either more or less than those entered in the tender of estimate.

**B. Extra Items :**

- The rate of extra item shall be decided as above or below tender with respect to R&B SOR (Bhavnagar) and GWSSB SOR during which item is executed. If any Item is not available in the same SOR, then latest SOR of R&B (Bhavnagar) shall be referred. And if any extra or miscellaneous item which is not mentioned in the Government S.O.R. The Contractor shall be bound to execute the same item as per the rate as agreed by Engineer-in-Charge. Payment of the any extra item will be paid as per the current SOR of R&B (Bhavnagar)/GWSSB considering higher or below tender rates approved.

**GC-68 ACTION WHEN NO SPECIFICATION IS ISSUED :**

In case of any class of work for which no specification is supplied by the BMC in the tender documents, such work shall be carried out in accordance with I.S.S. However if ISS do not cover the same, the work should be carried out as per standard Engineering practice subject to the approval of Engineer-in-charge.

**GC-69 ABNORMAL RATES :**

Contractor is expected to quote rate for each item after careful analysis of cost involved for the performance of the completed item considering all specifications and conditions of contract. This will avoid loss of profit or gain in case of curtailment or change or specification for any item. In case it is noticed that the rates quoted by a tenderer for any item is unusually high or unusually low, it will be sufficient cause for rejection of tender unless the BMC is convinced about the reasonableness of the rates on scrutiny of the analysis for such rate to be furnished by the tenderer on demand.

**GC-70 ASSISTANCE TO ENGINEER-IN-CHARGE :**

Contractor shall make available to Engineer-in-charge free of cost all necessary instruments and assistance in checking of any work made by the contractor for taking measurement of work.

**GC-71 TEST OF QUALITY OF WORK :**

1. All workmanship shall be of the best kind described in the contract document and in accordance with the instructions of Engineer-in-charge and shall be subjected from time to time to such test at contractor's cost as the Engineer-in-charge may direct at the place of manufacture of fabrication or on site or at any such place. Contractor shall provide assistance, instruments labour and materials as are normally required for examining measuring and testing any work workmanship as may be selected and required by Engineer-in-charge.
2. All tests will be necessary in connection with the execution of work as decided by Engineer-in-charge shall be carried out at an approved laboratory at contractor's cost.



3. The contractor shall furnish to Engineer - in - charge for approval when requested or if required by the specification adequate samples of all materials and finished goods to be used in work sufficiently in advance to permit test and examination thereof. All materials furnished and finished goods applied in work shall be exactly as per the approved samples.
4. All the testing charges shall be borne by the Contractor.

**GC-72 ACTION AND COMPENSATION IN CASE OF BAD WORKMANSHIP :**

If it appears to the Engineer-in-charge that any work has been executed with materials of inferior description, or quality or are unsound or with unsound imperfect or unskilled workmanship or otherwise not in accordance with the contract shall, on demand in writing from Engineer-in-charge or his authorized representative specifying the work, materials or articles comprises of, notwithstanding that the same may have been inadvertently passed, certified and paid for forthwith rectify or remove and reconstruct the work, specified and in the event of failure to do so within a period to be specified by Engineer-in-charge in his aforesaid demand, contractor shall be liable to pay compensation at the rate of one (1) percent of the tendered cost of work for every Ten (10) days limited to a maximum of Ten (10%) Percent of the value of work while his failure to do so continue and in the case of any such failure the Engineer-in-charge may on expiry of the notice period rectify and remove and re-execute the work or remove and replace with other at the risk and cost of the Contractor. The decision of the Engineer-in-charge as to any question arising under this clause shall be final and conclusive.

**GC-73 SUSPENSION OF WORK :**

Contractor shall, if ordered in writing by Engineer-in-charge or his representative temporarily suspended the work or any part thereof for such time (not exceeding two months) as ordered and shall not after receiving such written order proceed with the work until he shall have received a written order to proceed therewith the contractor shall not be entitled to claim compensation for any loss or damage sustained by him by reason of temporary suspension of work as aforesaid. An extension of time for completion of work will be granted to the contractor corresponding to the delay caused by such suspension of work if applied for the same provided the suspension was not consequent upon any default or failure on the part of the contractor.

**GC-74 OWNER MAY DO PART OF THE WORK :**

When the contractor fails to comply with any instructions given in accordance with the provisions of this contract, the BMC has the right to carry out such parts of work as the BMC may designate whether by purchasing materials and engaging labour or by the agency of another contractor. In such case the BMC shall deduct from the amount which otherwise might become due to contractor the cost of such work and materials with Ten (10%) percent added to cover all departmental charges and should the total amount thereof exceed the amount due to contractor, contractor shall pay the difference to BMC

**GC-75 POSSESSION PRIOR TO COMPLETION :**

The Engineer-in-charge shall have the right to take possession of or to use any completed or partly completed work or part of work. Such possession or use shall not be deemed to be an acceptance of any work completed in accordance with the contract. If such prior possession or use by Engineer-in-charge delays the progress of work, equitable adjustment in the time of completion will be made and the contract shall be deemed to be modified accordingly.

**GC-76 COMPLETION CERTIFICATE :**

As soon as the work has been completed in accordance with contract (except in minor respect that do not effect their use for the purpose for which they are intended and except for maintenance thereof) as per general conditions of contract and has passed the tests on completion, the Engineer-in-charge shall issue a certificate (hereinafter called completion certificate) in which he shall certify the date on which work has been completed and has passed the said tests and BMC shall be deemed to have taken over work on the date so certified. If work has been divided in various groups in contract, BMC shall be entitled to take over any group or groups before the other or others and there-upon the Engineer-in-charge will issue a completion certificate which will, however, be for such group or groups so taken over only. In order that contractor could obtain a completion certificate, he shall make good, with all speed any defect arising from the defective materials supplied by contractor or workmanship or any act or omission of contract that may have been discovered or developed after the work or group of works has been taken over. The period allowed for carrying out such work will be normally, one month. If any defect be not remedied within a reasonable time, BMC may proceed to do work at contractor's risk and expenses and deduct from the final bill such amount as may be decided by BMC. If by reason of any default on the part of the contractor, a completion certificate has not been issued in respect of every portion of work within one month after the date fixed by contractor for completion of work, BMC shall be at liberty to use work or any portion thereof in respect of which a completion-certificate has been issued, provided that work or the portion thereof so used as aforesaid shall be afforded reasonable opportunity for completion of this work for the issue of completion certificate. This clause shall be read in conjunction with GC-84.

**GC-77 SCHEDULE OF RATES :**

1. The price/rates quoted by the contractor shall remain firm till the issue of final certificate and shall be subject to price ADJUSTMENT CLAUSE GC-35. Schedule of rates shall be deemed to include and cover all costs expenses and liabilities of every description and all risks of every kind to be taken in executing, completing and handing overwork to owner by contractor. Contractor shall be deemed to have known the nature, scope, magnitude and the extent of work and materials required though contract documents may not fully and precisely furnish them. He shall make such provision in the schedule of rates as he may consider necessary to cover the cost of such items of work and materials as may be reasonable and necessary for completion work. The opinion of Engineer-in-charge as to the item of work shall be final and binding on Contractor although the same might be not shown on or described specifically in contract documents.

2. The Schedule of rates shall be deemed to include and cover the cost of all constructional plant, temporary work, pumps, materials, labour and all other materials in connection with each item in schedule of rates except GST and the execution of work or any portion thereof furnished complete in every respect and maintained as shown or described in the contract document or as may be ordered in writing during the continuance of the contract.
3. The Schedule of rates shall be deemed to include and cover the cost of all royalties and fee for the articles and processes, protected by letters patent or otherwise incorporated in or used in connection with work, also all royalties, and other payments in connection with materials of whatsoever kind for work and shall include an indemnity to-owner which contractor hereby gives against all action, proceeding, claims, damages, costs and expenses arising from the Municipal corporation in use of work of any such articles, processes or materials. Octroi of other Municipal or Local Board charges if levied on materials equipment of machineries to be brought to site for use on work shall be borne by the contractor.
4. No exemption or reduction of custom duties excise duties, sales-tax or any other taxes or charges of the CENTRAL or State Government or any local body whatsoever will be granted to obtain. All of such expenses shall be deemed to have been included in and covered by schedule of rates except GST. Contractor will also obtain and pay for all permits or other privileges necessary to complete work. GST will be paid extra in Bills.
5. The schedule of rates shall be deemed to include and cover risk on account of delay or interference with contractor's conduct of work which may occur from any cause including orders of BMC in the exercise of his power and no account of extension of time granted due to various reasons.

**GC-78 PROCEDURE FOR MEASUREMENT OF WORK IN PROGRESS :**

1. All measurements shall be in metric system. All the work in progress will be jointly measured by the representative of Engineer-in-charge and contractor's authorized agent. Such measurements will be got recorded in the measurement book by the Engineer or his authorized representative and signed by contractor or his authorized agent in token of acceptance. If the contractor or his authorized agent fails to be present whenever required by the Engineer-in-charge for taking measurements for any reasons whatsoever, the measurement will be taken by the Engineer-in-charge or his authorized representative notwithstanding the absence of contractor and these measurement will be deemed to be correct and binding on contractor.
2. Contractor will submit a bill in approved proforma in duplicate to the Engineer- in-charge of the work giving abstract and detailed measurements of various items executed during a month as mutually agreed. The Engineer-in-charge shall verify the bill and the claim, far as admissible, adjusted if possible, within 10 days of presentation of the bills.
3. In case of Tenders for completed items of work, contractor may be allowed 'Secured Advance' on the Security of materials brought to site for execution of the constructed items of work to

the extent of 75% of the value of materials of unperishable nature and an agreement be drawn up with contractor under which the owner secured a lien on these materials and is safe guarded against losses due to any reasons whatsoever. Recoveries of advance paid would not be postponed till the whole work is completed but shall be adjusted from his work done or the materials used, the necessary deductions being made when the items of work in which they are used and are billed for. When the mode of measurement is not covered by contract for any item of work it shall be as per latest I.S.I.

**GC-79 RUNNING ACCOUNT PAYMENT TO BE RECOVERED AS ADVANCES :**

All running account payments shall be regarded as payments by way of advance against the final payment only and not as payment for work actually done and completed and shall not preclude the requiring of bad, unsound and imperfect or unskilled work to be removed and taken away and reconstructed or to be considered as an admission of the due performance of contract or any part thereof.

**GC-80 NOTICE FOR CLAIM FOR ADDITIONAL PAYMENT :**

If the contractor considers that he is entitled to extra payment or compensation or any claim whatsoever in respect of work, he shall forthwith give notice in writing to the Engineer-in-charge about his extra payment and/or compensation. Such notice shall be given to the Engineer-in-charge within Ten (10) days from the happening of any event upon which contractor basis such claims and such notice shall contain full particular of the nature of such claim with full details and amount claimed. Failure on the part of the contractor to put forward any claim with the necessary particulars as above within the time above specified shall be an absolute waiver thereof.

**GC-81 PAYMENT OF CONTRACTOR'S BILL :**

The price to be paid by the BMC to contractor for the work to be done and for the performance of all the obligations under taken by the contractor under contract shall be based on the contract price and payment to be made accordingly for the work actually executed and approved by the Engineer-in-charge.

No payment shall be made for work costing less than Rs.5,000/- till the work is completed and a certificate of completion given. But in case of work estimated to cost more than Rs.5,000/- contractor on submitting the bill thereof will be entitled to receive a monthly payment, proportionate to the part thereof, approved and passed by Engineer-in-charge whose certificate of such approval and passing of the sum so payable shall be final and conclusive against contractor. This payment will be made after making necessary deductions as stipulated elsewhere in the contract documents for materials, security deposit, etc. The payment shall be released to the contractor within Forty five (45) days of submission of the bill in case of running bill and within Three (03) months in case of final bill, contractor shall present the bill duly pre-receipted on proper revenue stamp.

Payment due to Contractor shall be made by the crossed Accounts payee cheque in Indian currency forwarding the same to the registered office of the contractor. Owner shall not be responsible if the cheque is mislaid or misappropriated by unauthorized person.

**GC-82 FINAL BILL :**

The final bill shall be submitted by Contractor within two (02) month of the date of physical completion of work, Otherwise the Engineer-in-charge certificate of the measurement and of total amount payable for work shall be finalized binding on all parties.

**GC-83 RECEIPT FOR PAYMENT :**

Receipt for payment made on account of work when executed by a firm must be signed by a person holding power of attorney in this respect on behalf of contractor except when described in the tender as a limited company in which case the receipt must be signed in the name of the company by one of its principal officers or by some other person having authority to give effectual receipt for the Company.

**GC-84 COMPLETION CERTIFICATE :**

1. When the contractor fulfil his obligation as per terms of contract he shall be eligible to apply for completion certificate. Contractor may apply for separate completion certificate in respect of each such portion of work by submitting the completion documents along with such application for completion certificate.  
The Engineer-in-charge shall normally issue to contractor the completion certificate within 2 (Two) month after receiving an application thereof from contractor after verifying from the complete documents and satisfying himself that work has been completed in accordance with and as set out in the construction and erection drawings and the contract document. Contractor after obtaining the completion certificate is eligible to present the final bill for work executed by him under the terms of contract.
2. Within 2 (Two) month of completion of work in all respect contractor shall be furnished with a certificate by the Engineer-in-charge of such completion but no certificate shall be given nor shall work be deemed to have been executed, until all (1) scaffolding, surplus materials and rubbish is cleared off site completely (2) until work shall have been measured by the Engineer-in-charge whose measurement shall be binding and conclusive and (3) until all the temporary works, labour and staff colonies etc. constructed are removed and the work site cleaned to the satisfaction of the Engineer-in-charge. If contractors shall fail to comply with the requirements as aforesaid or before date fixed for the completion of work, the Engineer-in-charge may at the expenses of contractor remove such scaffolding, surplus materials and rubbish and dispose of the same he thinks fit.
3. The following documents will form the completion documents :
  - (a) Technical documents according to which work was carried out.

- (b) Construction drawings showing therein the modifications and corrections made during the course of execution signed by Engineer-in-charge.
  - (c) Completion certificate for "Embedded" or "Covered" up work.
  - (d) Certificate of final levels as set out for various works.
  - (e) Material appropriation statement for the materials issued by owner for work and list of surplus materials returned to BMC's store duly supported by necessary documents.
4. Upon expiry of the period of defects liability and subject to Engineer-in-charge being satisfied that work has been duly maintained by contractor during the defects liability period as fixed originally, or as extended subsequently and the contractor has in all respects made up by subsidence and performed all his obligations under contract, the Engineer-in-charge shall (without prejudice to the rights of owner in any way) give final certificate to that effect. The Contractor shall not be considered to have fulfilled the whole of his obligation until final certificate shall have been given by the Engineer-in-charge notwithstanding previous entry upon and taking possession, working or using of the same or any part thereof by owner.
5. Final Certificate only Evidence of Completion :

Except the final certificate no other certificate or payments against a certificate or an general account shall be taken to be an admission by owner of the due performance of contract or any part thereof or of occupancy validity of any claim by the contractor.

This clause shall be read in conjunction with clause no GC-76

**GC-85 TAXES, DUTIES ETC. :**

1. Contractor agrees to and does hereby accept full and exclusive liability for the payment of any and all taxes, including sales taxes, duties etc. imposed, increased or modified from time to time in respect of work and materials and all contributions and taxes for unemployment compensation, insurance and old age pension or annuities now or herein after imposed by CENTRAL or State Government authorities with respect to or cover and by the wages, salaries or other compensation paid to the persons employed by Contractor. If the contractor is not liable to sales tax assessment, a certificate to that effect from the competent authority shall be produced without which final payment to the contractor shall not be made. No. "P" "C" or "D" from shall be supplied by the Municipal Corporation, and the contractor shall be required to pay full sale tax as applicable.
2. Contractor shall be responsible for compliance with all obligations and restrictions imposed by the labour law or any other law affecting employer employee relationship.
3. Contractor further agrees to comply and to secure the compliance of all sub-contractors with applicable CENTRAL, State, Municipal and Local law and regulations and requirements. Contractor also agrees to defend, indemnify and hold harmless the owner from any liability or penalty which may be imposed by CENTRAL, State or Local authorities by reasons of any violation by contractor or sub-contractor or such laws, regulation of requirements and also from all claims, suits or proceedings that may be brought against owner arising under, growing out of or by reasons of work provided for by this contract, by third parties or by CENTRAL or State Government Authority or any administration sub-division thereof.

No work contract Tax or service Tax ( except GST) shall be paid/reimbursed by BMC. Any increase or decrease in any taxes, duties levies etc. during the contract period shall not be reimbursed or deducted. However, any new taxes, duties levies imposed during the contract period shall be reimbursed of submission of proof of payment before preparation of Final bill.

**GC-86 INSURANCE :**

Contractor shall at his own expenses carry and maintain with reputable Insurance Companies to the satisfaction of owner as follows :

**1. Employees State Insurance Act :**

Contractor agrees to and does hereby accept full and exclusive liability for compliance with all obligations imposed by the Employees' State Insurance Act 1948, and Contractor further agree to defend, indemnify and hold owner harmless from any liability or penalty which may be imposed by the CENTRAL or State Government or Local authority by reasons of any asserted violation by contractor or Sub-Contractor of the Employees' State Insurance Act, 1948 and also from all claims, suits or proceedings that may be brought against owner arising tender, growing out of or by reasons of the work provided for by this contract whether brought by employees of Contractor, by third parties or by CENTRAL or State Government authority or any administrative Sub-division thereof.

Contractor agrees to fill in with the Employees State Insurance Corporation, the declaration form and all forms which may be required in respect Contractor's or Sub- contractor's employees whose aggregate remuneration is Rs. 400/- p.m. or less and who are employed in work provided for or those covered by E.S.I from time to time under the agreement. The Contractor shall deduct and secure the agreement of the Sub-contractor to deduct the employees' contribution as per the first Schedule of the Employees' State Insurance Act from wages. Contractor shall remit and secure the agreement of Sub-contractor to remit to the State Bank of India Employees' State Insurance Corporation Accounts, the employees contribution as required by the Act Contractor agrees to maintain all cares and record as required under the Act in respect of employees and payments and contractor shall secure the agreements of the sub-contractors to maintain such records, any expenses incurred for the contributions or maintaining records shall be to contractor's or sub-contractor' account. Owner shall retain such sum as may be necessary from the contract value until contractor shall furnish satisfactory proof that all contribution as required by the Employees' State Insurance Act 1948 have been paid.

**2. Workman's Compensation And Employees Liability Insurance :**

Insurance shall be effected for all contractors employees engaged in the performance of this contact. If any part of work is sublet, contractor shall require the sub-contractor to provide workmans' compensation and employer's liability insurance which may be required by owner.

**3. Other Insurance required under law or regulation by owner :**

Contractor shall also carry and maintain any and all other insurance which may be required under any law or regulation from time to time. He shall also carry and maintain any other insurance which may be required by owner.

**GC-87 DAMAGE TO PROPERTY :**

1. Contractor shall be responsible for making good to the satisfaction of owner any loss of and any damage to all structures and properties belonging to owner or being executed or Procured by owner or of other Agencies within the premises of all work of owner, if such loss or damage is due to fault and / or the negligence or willful act or omission of contractor, his employees, agent representatives or Sub-contractors.
2. Contractors shall indemnify and keep owner harmless of all claims for damage to properties other than BMC's property arising under or by reasons of this agreement if such claims result from the fault and / or negligence or willful act of omission of contractor, his employees, agents, representatives or sub-contractors.

**GC-88 LABOUR LAWS AND REGULATIONS :**

1. The contractor shall be responsible for the strict compliance of and shall ensure strict compliance by his sub-contractor employees and agents of all labors and others laws, rules or regulations having the force of law affecting the relationship of employer and employee between the contractor / sub-contractor and their respective employees.
2. No labour below the age of eighteen (18) year be employed on work.
3. Contractor shall pay to the labors engaged on work according the law.
4. The Contractor and sub-contractors of the contractor shall obtain proper authority designated in this behalf under any applicable law, rules or regulations (including but not restricted to the factories Act and Contract Labour Abolition and Regulation Act 1970,) in so far as applicable) any and all such licenses, consents, Registration and / or other authorization as shall from time to time be or become necessary for relating to the execution of work or any part or portion thereof or the storage or supply of any materials or otherwise in connection with the performance of the contract and shall at all times observance by the sub-contractors, employees and agents of all terms and conditions of the said licenses, consents, regulation and other authorization and laws, rules and regulations applicable thereto.
5. Contractor shall submit labor license for this work/ if applicable as per prevailing rules.

**GC-89 CONTRACTOR TO INDEMNIFY OWNER :**

1. The Contractor shall indemnify and keep indemnified the owner and every member, officer and employee of owner from and against all action, claims, demands and liabilities whatsoever and in respect of the breach of any of the above clauses and/or against any claim, action or



demand by any workman / employee of the contractor or any sub-contractor and or from any liability anyway to any workman / employee of the contractor or any sub-contractor under any law, rule or regulations having the force of law, including but not limited to claims against the owner under the workman compensation Act 1923. The employees' Provident Funds Act 1952 and/or the Contract Labour (Abolition and Regulations) Act, 1970.

2. Payment of claims and damages :

If owner has to pay any money in respect of such claims or demands as aforesaid, the amount so paid and the cost incurred by the owner shall be charged to and paid by contractor without any dispute notwithstanding the same may have been paid without the consent or authority of the Contractor.

3. In every case in which by virtue of any provision applicable in the workman's Compensation Act 1923 or any other Act, be obliged to pay compensation to workman employed by Contractor the amount of compensation so paid, and without prejudice to the rights of BMC under sec.(12) Sub-section (2) of the said Act, BMC shall be at liberty to recover such amount from any surplus due to the contractor or the security deposit. BMC will not be bound to consent any claim made under section (12) Sub-section (2) of the said Act except or written request of Contractor and upon the consenting of such claim.

4. The Contractor shall protect adjoining sites against structural decorative and other damages that could be caused to adjoining premises by the execution of these works and made good at his cost, any such damage, so caused.

**GC-90 IMPLEMENTATION OF APPRENTICE ACT 1964 :**

Contractor shall comply with the provisions of the Apprentice Act 1964 and the orders issued thereunder from time to time. If he fails to do so, it will be a breach of contract. Contractor shall also be liable for any particular liability arising on account of any violation of the provisions of the Act by him.

**GC-91 HEALTH AND SANITARY ARRANGEMENTS FOR WORKERS :**

Contractor shall comply with all the rules and regulations of the local sanitary authorities or as framed by owner from time to time for the protection of health and sanitary arrangements of all labour directly or indirectly employed on the work of this contract.

**GC-92 SAFETY CODE :**

**GENERAL :**

Contractor shall adhere to safe construction practice and guard against hazardous and unsafe working conditions and shall comply with owner's safety rules set fourth herein.

1. First Aid and Industrial Injuries :
  - 1.1 Contractor shall maintain first aid facilities for its employees and those of his sub-contractor.
  - 1.2 Contractor shall make outside arrangements for ambulance service and for the treatment of industrial injuries. Name of those providing these services shall be furnished to Engineer-in-charge prior to start of construction, and their telephone numbers shall be prominently posted in contractor's field office.
  - 1.3 All injuries shall be reported promptly to Engineer-in-charge, and a copy of Contractor's report covering each personal injury requiring the attention of a physician shall be furnished to owner.
  
2. General Rules :
  - 2.1 Carrying, striking, matches, lighters inside the project area & smoking within the job site is strictly prohibited Violators of smoking rules shall be discharged immediately. Within the operation area, not hot work shall be permitted without valid gas safety, fire permits. The Contractor shall also be held liable and responsible for all lapses of his sub-contractors / employees in this regards.
  
3. Contractor's Barricades :
  - 3.1 The contractor shall erect and maintain barricades without any extra cost required in connection with his operation to guard or protect during the entire phase of the operation of this contract.
    - (i) Excavation
    - (ii) Housing areas,
    - (iii) Areas hazardous by the contractor's or the owners inspectors.
    - (iv) The owner's existing property liable to damage by the contractors operation, in the opinion of the Engineer-in-charge.
    - (v) Railroad unloading spots.
  - 3.2 The contractor's employees & those of his sub-contractors shall become acquainted with the owner's barricading practice and shall respect the provision thereof.
  - 3.3 Barricades and hazardous areas adjacent to but located in normal routes of travel shall be marked by red lantern at night.
  
- 4.0 Demolition :
  - 4.1 Before any demolition work is commenced and also during the process of the work all roads and open area adjacent to the work site shall either be closed or suitably protected.
  - 4.2 No electric cable or apparatus which is liable to be a source of danger shall remain electrically charged.
  
5. Scaffolding :

- 5.1 Suitable scaffolding shall be provided for workmen for all works that can not safely be done from the ground or from solid construction except such short period work as can be done safely from ladders. When a ladder is used, an extra mazdoor shall be engaged for holding the ladder and if the ladder is used for carrying materials as well, suitable foothold and handholds shall be provided on the ladder and the same shall be given inclination not steeper than 1 to 4 (1 horizontal and 4 vertical).
- 5.2 Scaffolding or staging more than 3.6 M (12') above the ground or floor, swing or suspended from an overhead support or erected with stationary support shall have a guard rail properly attached, bolted, braced and otherwise fixed at least 1.0 M (3') high above the floor or platform of scaffolding or staging and extending along the entire length of the outside ends thereof with only such openings as may be necessary for the delivery of materials. Such scaffolding or staging shall be so fastened as to prevent it from swaying from the building or structure.
- 6.0 Safety Equipment :
- 6.1 All necessary personal safety equipment as considered adequate by the Engineer-in-charge should be made available for the use to persons employed on the site and maintained in a condition suitable for immediate use, and the Contractor should take adequate steps to ensure proper use of equipment by those concerned.
- 6.2 Workers employed on mixing materials cement and lime mortars shall be provided with protective footwear and protective gloves.
- 6.3 Those engaged in white washing and mixing or stacking of cement bags or any materials which are injurious to the eyes shall be provided with protective goggles.
- 6.4 Those engaged in welding and cutting works shall be provided with protective face and eye-shield, hand gloves etc.
- 6.5 Stone breakers shall be provided with protective goggles and protective clothing, and seated at hand gloves etc.
- 6.6 When workers are employed in sewers and manholes are in use, the contractor shall ensure that the manhole covers are opened and are ventilated at least for an hour before the workers are allowed to get into the manholes, and the manholes opened shall be cordoned off with suitable railing and providing with warning signals or boards to prevent accident to the public.
- 7.0 Hoisting Equipment :
- 7.1 Use of hoisting machines and tackles including their attachments, and storage and supports shall conform to the following standards or conditions :
- 7.1.1 These shall be of good mechanical construction sound materials and adequate strength and free from patent defect and in good working order.

- 7.1.2 Every rope used in hoisting or lowering materials or as a means of suspension shall be of durable quality and adequate strength and free from patent defects.
- 7.1.3 Every crane driver or hoisting appliance operator shall be properly qualified and no person under the age of 21 years should be in charge of any hoisting machine including any scaffolding.
- 7.1.4 In case of every hoisting machine and of every chain ring, hook, shackle swivel and pulley block used in hoisting or lowering or as means of suspension the same working load shall be ascertained by adequate means. Every hoisting machine and all gear referred to above shall be plainly marked with the safe working load and the conditions under which it is applicable shall be clearly indicated. No part of any machine or any gear referred to above in this paragraph shall be loaded beyond the safe working load except for the purpose of testing.
- 7.1.5 In case of departmental machine, the safe working load shall be notified by the Engineer-in-charge. As regards contractor's machines, the contractor shall notify the safe working load of the machine to the Engineer-in-charge, whenever he brings any machinery to the site of work and get it verified by the Engineer-in-charge concerned.
- 8.0 Maintenance of Safety Devices :
- 8.1 All scaffolds, ladders and other safety devices mentioned or described herein shall be maintained in some conditions and no scaffold, ladder or equipment shall be altered or removed while it is in use. Adequate washing facilities should be provided at or near place or work.
- 9.0 Display or Safety Instructions :
- 9.1 These safety provisions should be brought to the notice of all concerned by display on a notice board at a prominent place at the work-spot. The person responsible for compliance of the safety code shall be named therein by the Contractor.
- 10.0 Enforcement of Safety Regulations :
- 10.1 To ensure effective enforcement of the rules and regulations relating safety precautions, the arrangements made by the contractor shall be open to inspection by the welfare Officer, Engineer-in-charge or safety Engineer of the owner or their representatives.
- 11.0 No Exemption :
- 11.1 Notwithstanding the above clause ,there is nothing to exempt the contractor from the operations of any other Act or rules in force in the Republic of India.
- 11.2 In addition to the above, the Contractor shall abide by the safety code provision as per C.P.W.D. Safety Code framed from time to time.

**GC-93 ACCIDENTS :**

It shall be the contractor's responsibility to protect against accidents on the work. He shall indemnify the Municipal Corporation against any claim for damage or for injury to persons or property resulting from, and in the course of work and also under the provision of the Workman's Compensation Act. On the occurrence of an accident arising out of the works which results in death or which is so serious as to be likely to result in death, the contractor shall within twenty four hours of such accident, report in writing to the Engineer-in-charge, the facts stating clearly and in sufficient details the circumstances of such accident and the subsequent action. All other accidents on the works involving injuries to persons or damage to property other than that of the contractors shall be promptly reported to the Engineer-in-charge stating clearly and in sufficient details and facts and circumstances of the accidents and the action taken. In all cases the contractor shall indemnify the Municipal Corporation against all loss or damage resulting directly or indirectly from the Contractor's failure to report in the manner aforesaid. This includes penalties or fine consequence of failure to give notice under the workman's compensation Act or failure to confirm to the provisions of the said Act in regard to such accidents.

In the event of an accident in respect of which compensation may become payable under the workmens compensation Act VIII of 1923 including all modification thereof whether such compensation may become payable by the contractor or by the Municipal Corporation as principal employer, the Engineer-in-charge may retain out of money due and payable to the contractor such sum or sums of money as may, in the opinion of the Engineer-in-charge be sufficient to meet such liability. On receipt of award from the labour commission in regard to quantum of compensation, the difference in amount will be adjusted.

**GC-94** It is clarified that if the contractor makes his own arrangements for water required for construction and labour camp etc. by drilling bore. No water charges will be recovered from the contractor. On the other hand, even if the contractor is not taking connection and makes other arrangement to use Municipal water by tanker or tapping water from near private connection even though water charges shall be recovered as per relevant condition of the tender.

**GC-95 TESTING AND INSPECTION CHARGE :-**

The contractor shall have to borne all charges for testing and inspection purpose. The contractor shall have to bear the too and for travelling allowance of BMC official.

**GC-96 SPECIAL CLAUSES REGARDING REFUND/RECOVERY OF EXCESS/ADDITION SECURITY DEPOSIT :-**

In case the total amount of work done is less by 5% of the contract value, prorate S.D. to that extent may be refunded to the contractor while releasing the payment of final bill. In short, the S.D.to be retained by the Corporation after payment of final bill shall be equal to 5% of the amount of final bill as per the prevailing norms or as per the norms decided from time to time.

The Additional S.D. shall be recovered from the running bill. When the total of any of work done by the Contractor upto running bills under consideration is more than 5% of the contract value. However, such S.D. shall be recovered in the round figure of Rs.1000/- i.e. the amount of work done when it exceeds 5% of the contract value it shall be rounded off to the nearest multiple of Rs. 25000/- such additional S.D. (5% of the additional amount) shall be recovered for the works amounting to Rs. 5/- Lacs or more.

**GC-97** If the contractor fails to complete the work and the Commissioner on behalf of the Corporation takes actions in accordance to 2(a) or (b) or (c) of clause GC-49 of the contract then in such cases the remaining work shall be carried out at the risk and cost of the original contractor by advertising the tender for the remaining work and the whole administrative process right from inviting the tenders to finalising the tender etc. shall have to be repeated. For this, a fixed amount of Rs. 1000/- shall be recovered from the original contractor towards the cost of re-advertisement and other administrative charges incurred by the department in finalising the contract for the remaining work. If however, separate advertisement is issued for the instant work, actual cost of advertisement shall be recovered. Such recovery shall be in addition to the recovery to be made under such other relevant clauses.

**GC-98** No Contractor shall employ any person who is under the age of 15 years. If any contractor found employing person or persons under the age of 15 years, during course of the construction at any stage, legal actions shall be taken against him as stipulated in Child Labour (Prohibition & Regulation) Act 1986 and also, a penalty of Rs.20,000/-(Rupees Twenty thousand) shall be imposed which shall be deposited with District Collector in Child Labour Rehabilitation cum Welfare Fund.

**GC-99** The Engineer-in-charge shall have power to take any alteration in, or addition to the original specifications, drawings, designs and instruction that may appear to him to be necessary or advisable during the progress of the work, and the contractor shall be bound to carry out the work in accordance with any instructions in this connection which may be given to him in writing signed by the Engineer-in-charge and such alteration shall not invalidate the contract and any additional work which the contractor may be directed to do in the manner above specified as part of the work shall be carried out by the contractor on the same conditions in all respect on which he agreed to do the main work and at the same rates as are specified in the tender for the main work. And if the additional and altered work includes any class of work for which no rates is specified in this contract then such class of work shall be carried out at the rates entered in the schedule of rates of Municipal Corporation or at the rates mutually agreed upon between the Engineer-in-charge and the contractor whichever are lower if the additional or altered work for which no rate is entered in the schedule of Rates of Municipal Corporation is ordered to be carried out before the rates are agreed upon then the contractor shall, within seven days of the date of receipt by him of the order to carry out the work, inform the Engineer-in-charge of the rate which it is his intention to charge for such class of work and if the Engineer-in-charge does not agree to this rate he shall by notice in writing be at liberty to cancel his order to carry out such class of work, and arrange to carry it out in such manner as he may consider advisable provided always that if the contractor shall commence the work or incur any expenditure in regards thereto before the rates shall have been determined as lastly herein before mentioned, then in such case he shall only be entitled to be paid in respect of the work carried out or expenditure incurred by

him prior to the date of the determination of the rate as aforesaid according to such rate or rates as shall be fixed by the Engineer-in-charge. In the event of a dispute, the decision of the Commissioner will be final.

Where, however, the work shall have to be executed according to the designs; drawings and specifications recommended by the contractor and accepted by the competent authority the alteration above referred to shall within the scope of such designs drawings and specification appended to the tender.

**GC-100** The contractor shall not be entitled to claim any compensation from Municipal Corporation for the loss suffered by him on account of delay by Municipal Corporation in the supply of materials entered in Schedule 'A' where such delay is caused by

- (1) Difficulties relating to the supply of Railway wagons & availability of Government controlled materials-
- (2) Force Majeure.
- (3) Act of God.
- (4) Act of the Nation's enemies or any other reasonable cause beyond the control of Municipal Corporation.

In the case of such delay in the supply of material the Municipal Corporation shall grant such extension of time for the completion of the work as shall appear to the Commissioner to be reasonable in accordance with the circumstances of the case.

The decision of the Commissioner as to the extension of time shall be accepted as final by the contractor.

**GC-101 PATENTS AND ROYALTIES :**

1. Contractor, if licensed under any patent covering equipment, machinery, materials or composition of matter to be used or supplied or methods and process to be practiced or employed in the performance of this contract agrees to pay all royalties and license fees which may be due with respect thereto. If any equipment, machinery materials composition matters, to be used or supplied or methods practiced or employed in the performance of this contract, is covered by a patent under which the contractor is not licensed, then the contractor before Supplying/using the equipment, machinery, materials, compositions methods of process shall obtain such license and pay such royalties and license fees as may be necessary for performance of this contract. In the event contractor fails to pay such royalty or obtain any such license any suit for infringement of such patents which is brought against the contractor or the owner as a result of such failure will be defended by the contractor at his own expenses and the contractor will pay any damages and costs awarded in such suit. The contractor shall promptly notify the owner if the contractor has acquired knowledge of any plant under which a suit for infringement could be reasonably brought because of the use by the owner of any equipment, machinery, materials, process methods to be supplied hereunder. Contractor agrees to and do hereby grant to owner together with the right to extend the same to any of the subsidiaries of the owner an irrevocable royalty free license to use in any country, any invention made by the contractor or his employees in or as a result of performance of work under the contract.
2. With respect to any sub-contract entered into by the contractor pursuant to the provisions of the relevant clause hereof, the contractor shall obtain from the sub contractor an understanding

to provide the Surat Municipal Corporation with the same patent protection that contractor is required to provide under the provisions of this clause.

3. The owner shall indemnify and save harmless the contractor from any loss on account of claim against contractor for the contributory infringement of patent rights arising out of and based upon the claim that the use by the owner of the process included in the design prepared by the owner and used in the operation of the plant infringes on any patent rights.

**GC-102 AS BUILT COMPLETION DRAWINGS:**

Contractor shall have to prepare and submit AS BUILT DRAWINGS with detailed L/S C/S of component etc. showing Alignment plan, Chainage, RL of invert, RL of Ground level at every 30 meter, with position of each every manhole etc. in soft copy( Auto Cad - 2013 ), hard copy ( 3 sets) with readable and proper standard scale. Drawing should be submitted time to time with physical completion progress done by the contractor on site.

**GC-103 CONNECTIONS AT EXISTING LINE/MANHOLE/PS**

Contractor shall complete the job with existing connections for manholes, line or Storm Drains where required as per separate in BOQ.

Signature and seal of Contractor :-

Name :-

Address :-

EXECUTIVE ENGINEER,

BHAVNAGAR MUNICIPAL CORPORATION,

BHAVNAGAR.



## 8.0 SPECIAL CONDITIONS OF CONTRACT

### 1.0 GENERAL CONDITIONS :

- 1.1 i] Service roads are laid within and upto the site of the work. These will be available to the contractor subject to any limitations imposed by BMC.
- ii] The contractor shall have to obtain tokens for himself and to obtain gate passes for removing any of his materials outside the premises. The contractors persons entry and exit will be through main gate only.
- iii] Non availability of access roads or railway siding or permits for entry of vehicles and equipment at any specific area shall in no case be the cause to condone any delay in the execution of the works or be the cause for any claims or extra compensations.
- 1.2 Water Supply & water charges  
For all the purposes connected with the work, the contractors shall be allowed the use of water from the Municipal mains wherever available at prevailing rates of Rs 10.00 per 1000 liters of water. The contractors, however, will have to make their own arrangements to get at their cost necessary metered water connections from the Municipal mains.  
In no case water will be supplied free of cost.  
If Municipal mains are not available nearby the contractor shall have to make his own arrangements at his cost for water required for construction purpose.
- 1.3 Electric Supply for construction purpose.  
The contractor shall make his own arrangements at his own cost for electric supply required for operating various plants and machineries required for the work and for general lighting purpose for site, office, labour colony etc. The energy bills shall also be paid by the contractor.

### 2.0 DOCUMENTS :

- 2.1 The Tenders as submitted will consists of the following :
- i] Complete set of tender documents as sold duly filled in and signed by the tenderer as prescribed in different clauses of the tender documents.
- ii] Declaration showing all works of similar types and magnitudes carried out and on hand with the contractor and the value of works that remains to be executed must accompany the tender.
- iii] Solvency Certificate of Bank or a Revenue Officer of desired amount as stated
- iv] Tender Fees and Earnest money deposit must accompany the tender.
- v] Tenderer should submit the True Copy of the Certificates of Registration and all relevant document for Qualification along with the tender without which the tender will not be considered.
- 2.2 Signature of Tenderer  
The tender shall contain the name, residence and place of business of person or persons submitting the tender and shall be signed by the tenderer with his usual signature. In case of partnership firm name of all the partners shall be given and tender shall be signed by duly authorized representative followed by the name and designation of the person signing. Tender by a corporation limited company shall be signed by an authorized representative and a power

of attorney in behalf shall accompany the tender. A copy of the constitution of the firm with the name of all the partners to be furnished.

**3.0 TRANSFER OF TENDER DOCUMENTS :**

Transfer of tender documents purchased by an intending tenderer to another is not permissible.

**4.0 RIGHT TO OWNER TO ACCEPT OR REJECT TENDER :**

The right to accept the tender will rest with the BMC. The BMC, however, does not bind itself to accept the lowest tender, and reserves to itself the authority to reject any or all the tenders received without assigning any reason whatsoever. Tenders in which any of the particulars and prescribed information are missing or are incomplete in any respect and/or the prescribed condition are not fulfilled are liable to be rejected.

**5.0 CO-ORDINATION OF WORK :**

The Engineer-in-charge shall co-ordinate the works of various agencies engaged at site to ensure minimum disruption of work carried out by different agencies. It must be the responsibility of the contractor to plan and execute the work strictly in accordance with site instructions to avoid hindrance to the work being executed by other agencies.

**6.0 INTERPRETATION OF CONTRACT DOCUMENTS :**

6.1 Except if and to the extent otherwise provided by the contract, the provisions of the General Conditions of Contract and special conditions shall prevail over those of any other documents forming part of the contract. Several documents forming the contract are to be taken as mutually explanatory, should there be any discrepancies, inconsistencies, errors or omissions in the contracts or any of them, the matter may be referred to the Engineer-in-charge who shall give his decisions and issue to the contractor instructions directing in what manner the work is to be carried out. The decision of the Engineer-in-charge shall be final and conclusive and the contractor shall carry out the work in accordance with this decision.

6.2 Works shown upon the drawings but not mentioned in the specifications or described in the specifications without being shown on the drawings shall nevertheless be held to be included in the same manner as if they had been specifically shown upon the drawings and described in the specifications.

6.2.1 The tender GA drawings are for the guidance of the arrangement of the various components, however at site the location of the component may change as per site conditions.

6.3 i] The various documents forming the contract are the essential parts of the contracts and a requirement occurring in one is as binding as though occurring in all, they are intended to be mutually explanatory and complementary and to describe and provide for a complete work.

ii] In the event of any discrepancies, the various documents forming the contract or in any one document, the following order of precedence should apply ---

a] Dimensions & quantities ---

i] Drawings.

ii] Schedule 'B' of the tender form.

On drawings, figures, dimensions, unless obviously incorrect will be followed in preference to shown dimensions

- b] Description ---
- i] Schedule `B' of the tender form.
  - ii] Drawings
  - iii] Specifications

In case of defective description or ambiguity, the Engineer- in-charge should issue further instructions / directions in what manner the work is to be carried out, it being understood that the best modern practice is to be followed. The contractor should forthwith comply with such instructions

- iii] The contractor should take no advantage of any apparent error or omissions in drawings or specifications and the Engineer-in- charge shall make such corrections and interpretations as necessary to fulfill the intent of the plans and specifications.

#### **7.0 FORCE MAJEURE :**

Any delays in or failure of the performance of either part hereto shall not constitute default hereunder or give rise to claims for damages, if any, to the extent such delays or failure of performance is caused by occurrences such as Acts of God or the public enemy; expropriation or confiscation of facilities by Government authorities, compliance with any order or request of any Governmental authorities, acts of war, rebelling or sabotage or fires, floods, explosions, riots or illegal strikes. The contractor shall keep records of the circumstances referred to above and bring these to the notice of the Engineer-in-charge in writing immediately on such occurrences.

#### **8.0 FORFEITURE OF RETENTION MONEY :**

Whenever any claim against the contractor for the payment of a sum of money arises out of or under the contract, the BMC shall be entitled to recover such sum by appropriating in part or whole of the retention money of the contractor. In case, the retention money is insufficient or if no retention money has been taken from the contractor, then the balance or the total sum recoverable, as the case may be, be deducted from any sum then due or which at any time thereafter may become due to the contractor. The contractor shall pay on demand any balance remaining due.

#### **9.0 NO COMPENSATION FOR ALTERATION IN OR RESTRICTION OF WORK :**

If at any time after the commencement of the work, the corporation shall for any reason whatsoever not require the whole or part thereof as specified in the tender to be carried out, the Engineer-in-charge shall give notice in writing of the fact to the contractor, who shall have no claim to any payment or compensation whatsoever on account of any profit or advantage which he might have derived from the execution of the work in full, but which he did not derive in consequence of the full amount of the work not having been by reason of any alterations having been made in the original specifications, drawings, designs and instruction which shall not involve any curtailment of the works as originally contemplated.

#### **10.0 RIGHT OF THE CORPORATION TO DETERMINE/TERMINATE CONTRACT :**

- i] The Corporation shall, at any time, be entitled to determine and terminate the contract, if in the opinion of the Corporation the cessation of the work becomes necessary owing to paucity of funds or for any other cause whatsoever, in which case the cost of approved

materials at the site as verified and approved by the Engineer-in-charge and of the value of the work done to date by the contractor shall be paid for in full at the rate specified in the contract. A notice in writing from the Corporation to the Contractor of such determination and the reason, thereof shall be the conclusive proof of the fact that the contract has been so determined and terminated by the Corporation.

- ii] Should the contract be determined under sub-clause (i) of this clause and the contractor claims payments to compensate expenditure incurred by him in the expectation of completing the whole of the work, the Corporation shall consider and admit such claims as are deemed fair and reasonable and are supported by vouchers to the satisfaction of the Engineer-in-charge. The decision of the Commissioner on the necessity and propriety of any such expenditure shall be final and conclusive and binding on the contractor.

**11.0 DRAWINGS TO BE SUPPLIED BY THE CORPORATION :**

- 11.1 The tender purpose drawings are attached herewith.

**12.0 RESPONSIBILITY FOR LEVEL & ALIGNMENT :**

The contractor shall be entirely and exclusively responsible for the horizontal and vertical alignment, the level and correctness of every part of the work and shall rectify any errors or imperfections therein. Such rectification shall be carried out by the contractor at his own cost, when instructions are issued to that effect by the Engineer-in-charge.

**13.0 CONTROLLED MATERIALS (ESSENTIALITY CERTIFICATE) :**

- [i] As regards controlled materials, the corporation will help to arrange for the permit as far as possible and help the contractor in securing the same. All incidental charges not within procuring these materials shall be borne by the Contractor himself. Though the Corporation will help to manage for the permit as far as possible and help the Contractor in obtaining the materials it shall not accept any responsibility for any delay or loss on account of delay caused to the Contractor while obtaining the same.
- [ii] The Contractor shall submit to Engineer-in-charge on close of every calendar month, the monthly returns in the prescribed forms as to the receipt and actual use of the controlled materials during the months.
- [iii] The Contractor shall permit the Engineer-in-charge or his representatives to inspect the stock of the controlled materials stored by him at any time, whenever the Engineer-in-charge or his representative(s) desire(s).

**14.0 DISCREPANCIES BETWEEN INSTRUCTIONS :**

Should any discrepancy occur between the various instructions furnished to the contractor, his agents or staff, or any doubt arises as to the meaning of any such instruction or, should there be an misunderstanding between the instructor's staff and the Engineer-in-charge's staff, the Contractor shall immediately report the matter in writing to the Engineer-in-charge whose decision thereon shall be final and conclusive and no claim for losses alleged to have been caused by such discrepancies between instructions, doubts or misunderstanding shall in any event be admissible.

**15.0 INSPECTION OF WORK :**

The Engineer-in-charge or his representative will have full power and authority to inspect the works at any time wherever in progress, either on the site or at the Contractor's premises/workshops wherever situated, premises/workshop of any person, firm or corporation where materials are being made or are to be supplied, and the contractor shall afford or procure for the Engineer-in-charge or his representative every facility and assistance to carry out such inspection. The contractor shall at all times during the usual working hours and at all other times at which reasonable notice of the intention of the Engineer-in-charge or his representative to visit the works shall have been given to the Contractor, either himself be present to receive orders and instructions or have a responsible agent duly accredited in writing present for the purpose. Orders given to the Contractor's agent shall be considered to have the same force as if they had been given to the Contractor himself. The Contractor shall give not less than seven days' notice in writing to the Engineer-in-charge or his representative before covering up or otherwise placing beyond reach of inspection and measurement any other work in order that the same work may be inspected and measured. In the event of breach of the above, the same shall be uncovered at contractor's expense for carrying out such measurements or inspections.

**16.0 TESTS FOR QUALITY OF WORK :**

All workmanship shall be of the respective kinds described in the contract documents and in accordance with the instructions of the Engineer-in-charge and shall be subjected from time to time to such tests at Contractor's cost as the Engineer-in-charge may direct at the place of manufacture or fabrication or on the site or at all or any such places. The Contractor shall provide assistance, instruments, labour and materials as are normally required for examining, measuring and testing any workmanship as may be required and selected by the Engineer-in-charge.

**17.0 THE CORPORATION MAY DO PART OF THE WORK :**

Upon failure of the Contractor to comply with any instructions given in accordance with the provisions of this contract, the Corporation has the alternative right, instead of assuming charge of entire work, to place additional labour force, tools, equipment's and materials on such parts of the works, as the Corporation may designate or also engage another Contractor to carry out the work. In such cases, the Corporation shall deduct from the amount which otherwise becomes due to the Contractor, the cost of such work and materials with 10% added to overall departmental charges and should the total amount thereof exceed the amount due to the Contractor, the Contractor shall pay the difference to the Corporation.

**18.0 ACCIDENT LIABILITIES :**

18.1 The Contractor shall be responsible for and shall pay the expenses of providing medical aid to any workmen who may suffer a bodily injury as a result of an accident. If such expenses are incurred by Government, the same shall be recoverable from the contractor for with and be deducted, without prejudice to any other remedy of Government from amount due or that may become due to the Contractor.

18.2 The contractor shall provide all necessary personal safety equipment and first aid apparatus available for the use of the person employed on the site and shall maintain the same in suitable condition for immediate use at any time and shall comply with the following regulations in connection therewith. The workers shall be required to use the equipment so provide by the

Contractor and Contractor shall take adequate steps to ensure proper use of the equipment by those concerned. When work is carried on in approximates to any place where there is a risk of drowning all necessary equipment shall be provided and kept for use and all necessary steps shall be taken for the prompt rescue of any person, in danger. Adequate provision shall be made for prompt first aid treatment of all injuries to be sustained during the course of the work.

**19.0 INSURANCE :**

The Contractor shall take "All Contract Risk Insurance Policy" for the estimated cost of this work "Work's Man Compensation Policy" for all workers and labors of contractor and client working at site and "Third Party Insurance Policy" to fully cover all third party type risk. The insurance policy so taken by the Contractor for such purposes shall be in the joint name of the Contractor and the client and the policy shall be deposited with the client.

**20.0** Contractors shall have to use maximum machinery for the work as per the direction of Engineer-In-Charge.

**21.0** If possible, space for stacking the surplus excavated earth will be provided by BMC. Otherwise the contractor shall arrange for the same at no extra cost to BMC.

SIGNATURE OF THE CONTRACTOR.

EXECUTIVE ENGINEER,  
BHAVNAGAR MUNICIPAL CORPORATION,  
BHAVNAGAR.

## 9.0 PERCENTAGE RATE TENDER & CONTRACT FOR WORKS

### GENERAL RULES AND DIRECTIONS FOR THE GUIDANCE OF CONTRACTORS

- (1) All work proposed to be executed by contract shall be notified in a form of invitation to tender Posted on a board hung up in the Municipal Office and signed by the Commissioner.  
This form will state the work to be carried out, as well as the date for submitting and opening tenders, and the time allowed for carrying out the work; also the amount of earnest money to be deposited with the tender, and the amount of the security deposit to be deposited by the successful tenderer and the percentage, if any to be deducted from bills. It will also state whether a refund of quarry fees, royalties dues ground rents & water-charges will be granted. Copies of the specifications, designs drawings and estimated rates; schedule rates and any other documents required in connection with the work which will be signed by the Executive Engineer, for the purpose of identification shall also be opened for inspection by contractors at the office of the Executive Engineer, during office hours.  
Where the works are proposed to be executed according to the specifications recommended by a contractor and approved by a competent authority on behalf of the Bhavnagar Municipal Corporation such specification with designs and drawings shall form part of the accepted tender.
- (2) In the event of the tender being submitted by a firm, it must be signed by each partner thereof, and in the event of the absence of any partner, it shall be signed on his behalf by a person holding a power of attorney authorizing him to do so.
- (3) Receipt for payments made on account of any work when executed by a firm, should also be signed by all the partners, except where the contractors are described in their tender as a firm, in which case the receipts shall be signed in the name of the firm by one of the partners, or by some other person having authority to give effectual receipt for the firm.
- (4) Any person who submits a tender shall fill up the usual printed form including the column total according to estimated quantities, stating at what rate he is willing to undertake each item of the work. Tenders which propose any alteration in the work specified in the said form of invitation to tender, or in the time allowed for carrying out the work, or which contain any other conditions of any sort, will be liable to rejection. No single tender shall include more than one work, but contractors who wish to tender for two or more works shall submit a separate tender for each. Tenders shall have the name and the number of the works to which they refer written outside the envelope.
- (5) The Commissioner or his duly authorized Assistant will open tenders in the presence of any intending contractors who may be present at the time, and will enter the amounts of the several tenders in a comparative statement in suitable form. In the event of a tender being accepted, the contractors shall thereupon, for the purpose of identification sign copies of the specifications and other documents mentioned. In the event of a tender being rejected the deposit will be refundable on application.

- (6) The Municipal Corporation shall have the right of rejecting all or of the tenders without assigning any reason.
- (7) No receipt for any payment alleged to have been made by a contractor regard to any matter relating to this tender or the contract shall be valid and binding on Municipal Corporation unless it signed by the Competent Authority,.
- (8) The memorandum of work to be tendered for and the schedule of materials to be supplied by the Municipal Corporation and their rates shall be filled in and completed by the office of the Executive Engineer, before the tender form is issued. If a form issued to an intending tenderer has not been so filled in and completed, he shall request the said office to have this done before he completes and delivers his tender.
- (9) All work shall be measured net by standard measure and according to the rules and custom of the Municipal Department of Bhavnagar Municipal Corporation without reference to any local custom.
- (10) Under no circumstances shall any contractor be entitled to claim enhanced rates for any items in this contract.
- (11) Every contractor shall, if so desired by the Commissioner, produce along with his tender a banker's certificate of his financial stability. If he fails to produce such a certificate his tender will not be considered.
- (12) All corrections and additions or pasted slips should be initialed.
- (13) The measurements of work will be taken according to the usual method in use in the BMC and no proposals to adopts alternative methods will be accepted. The Commissioner's decision at to what the usual method in use in the BMC will be final.
- (14) The tender for work shall remain open for a period at 180 days from the date of receipt of this tender for this work and that the tenderer shall not be allowed to with draw or modify the offer on his own during this period. If any tenderer with - draw or makes modifications of additional in the terms and conditions of his tender not acceptable to the corporation shall without prejudice to any right or remedy be at liberty to forfeit in full the said earnest money absolutely.

SIGNATURE OF THE CONTRACTOR.

EXECUTIVE ENGINEER,  
BHAVNAGAR MUNICIPAL CORPORATION,  
BHAVNAGAR



# ITEM SPECIFICATION

## 10.0 PREAMBLE TO TECHNICAL SPECIFICATION (PRICE - BID)

- 1.0 The Schedule of Quantities and Rates are to be read for the purpose of pricing in conjunction with instructions of tenderers, technical specifications, drawings and General conditions for contract for Civil works.
- 2.0 The price shall be quoted in the respective item sheets of schedule of quantities and rates shall be of all-inclusive value for the work described including all costs and expenses which may be required in for the execution of the work described together with all general risks, liabilities and obligations set forth or implied in the document on which the tender is based.
- 3.0 The quantities furnished are approximate. In the event of actual quantities varying from those furnished herein below or items deleted or added, Rate quoted for the that work shall remain, firm and no extra claims in this respect will be entertained. The payment shall be made based on the actual quantities executed for the completion of work.
- 4.0 All works shall be carried out strictly as per detailed specification whether actually specified or not. If not specified, as per directions of owner/Engineer-in-charge.
- 5.0 **Percentage rate** quoted by tenderer shall be firm even if the contract is split.
- 6.0 **Percentage rate** and the total amount entertained in the summary of cost, sheet of schedule of quantities and Rates shall be written in ink or may be filled online as the case may be and shall be entered both in figures and words.
- 7.0 Detailed specifications of items of work are described under section Detailed Technical Specification for each item of schedule of quantities and Rates. The section gives guidelines to the reference of relevant clauses of specifications and mode of measurement. Tenderer shall read this in conjunction with other technical specifications and quote accordingly.
- 8.0 The measurements shall be as described in the detailed Technical specification of items of work, all measurements being not in accordance with the drawings with no allowance for waste.
- 9.0 If Tenderers need any clarifications, they should obtain the same in writing from Owner/Engineer-in-charge. No notice will be taken of any verbal discussion in such matters.

mm	: Millimeters	R.C.C.	: Reinforced Cement Concrete
cm	: Centimeters	Wt.	: Weight
mt.	: Meters	Kg	: Kilogramme
Km.	: Kilometers	M.T.	: Metric Tonne
Sq.mt.	: Square Meters	M.D.	: Metre Depth
Cu.mt.	: Cubic Meters	M.S.	: Mild Steel
R.mt.	: Running Meters	I.S.	: Indian Standard

No. : Numbers

CRS : Corrosion Resistance Steel

C.I. : Cast Iron

## 11.0 MEMORANDUM

I / We \_\_\_\_\_ the undersigned do hereby tender for carrying-out the work described in the schedule subject to the conditions annexed in Schedules attached herewith in tender documents.

1. Name of Work : CONSTRUCTION OF STORE AREA FOR DRAINAGE DEPARTMENT, BMC AT F.P. NO. 66 UNDER T.P. SCHEME NO. 7 ADHEWADA, BHAVNAGAR
2. Estimated Cost : Rs. 2,83,33,059.00 as per detailed tender notice
3. Earnest Money Deposit : Rs. 2,83,331.00 as per detailed Notice
- 3A. Retention money : deducted 5% from every bill
4. Security Deposit rules : 5% (Five) of the Contract Amount. or prevailing Govt
5. Time allowed for the completion of work form in written : 12 Months in written order to commence
6. Penalty for delay : 0.1% (Zero point one percent) of the contract price per day maximum up to 10% ( Ten Percent ) of the Tender Amount.
7. The progress of work should confirm to : 1/4 of the work in 1/4 of the time.  
1/2 of the work in 1/2 of the time.  
3/4 of the work in 3/4 of the time.
8. Retention money deduction from Running Account Bill. : 5% (Five percent)
9. Period for O & M Contract : N.A.
10. Period of liability for defects : 24 months after completion of work

SIGNATURE OF THE CONTRACTOR.

EXECUTIVE ENGINEER,  
BHAVNAGAR MUNICIPAL CORPORATION,  
BHAVNAGAR

## **12.0 GENERAL SPECIFICATIONS**

### **1.0 GENERAL :**

- 1.1 All the items occurring in the work and as found necessary during actual execution shall be carried out in the best workman like manner as per specification and the written order of the Engineer-in-charge.
- 1.2 Extra claim in respect of extra work shall be allowed only if such work is ordered to be carried out in writing by the Engineer-in-charge.
- 1.3 The Contractor shall engage a qualified Engineer for the Execution of work who will remain present for all the time on site and will receive instructions and orders from the Engineer-in-charge or his authorized representative. The instruction and orders given to the contractor's representative on site shall be considered as it will be to the contractor himself.
- 1.4 **The work order book** as prescribed shall be maintained on the site of the work by the Contractor and the contractor shall sign the orders given by the inspecting officers and shall carry out them properly.
- 1.5 Quantities specified in the tender may vary at the time of actual execution and the contractor shall have no claim for compensation on account of such variation.
- 1.6 Figured dimensions of drawings shall supersede measurements by scale,. Special dimensions in the specification shall supersede all other dimensions.
- 1.7 Use of I. S. Code shall mean its latest applicable version for respective items.

### **2.0 CLASSIFICATION OF STRATA :**

- 2.1 All materials encountered in excavation will be classified in the following groups irrespective of excavating the materials and the decision of the Engineer-in-charge in the regard shall be final and binding to the contractor.

### **2.2 SOILS :**

Soils of all sorts, silt, sand gravel soft murrum, stiff clay, kankar and other soft excavation not covered in the item mentioned hereunder.

### **2.3 HARD MURRUM :**

Hard materials comprising of all kinds of disintegrated rock or shale of indurate conglomerate interspersed with boulders of size between 0.02 Cu.mt. and 0.75 Cu.mt., weathered and decomposed rock which could be removed with pick, bar shovel, wedges and hammers, though not without some difficulties.

**2.4 SOFT - ROCK :**

This shall include all materials which is rock but which does not need blasting and can be removed with a pick, bar, wedges, pavement breakers, pneumatic tools etc.

SIGNATURE OF THE CONTRACTOR.

EXECUTIVE ENGINEER,  
BHAVNAGAR MUNICIPAL CORPORATION,  
BHAVNAGAR

## 13.0 DETAILS SPECIFICATION OF MATERIAL

### M-1 WATER :

- 1.1 Water shall not be salty or brackish and shall be clean reasonably clear and free from objectionable quantities of silt and tract of oil and injurious alkalis, salts, organic matter and other deleterious materials which will either weaken the mortar or concrete or cause efflorescence of attach the steel in R.C.C. Container for transport, storage and handling of water shall be clean. Water shall conform to the standards specified in I.S. 456-1978.
- 1.2 If required by the Engineer-in-charge it shall be tested by comparison with distilled water. Comparison shall be made by means of standard cement tests for soundness, time of setting and mortar strength as specified in I.S. 269-1976. Any indication of unsoundness, charge in time of setting by 30 minutes or more or decrease of more than 10 percent in strength of mortar prepared with water sample when compared with the results obtained with mortar prepared with distilled water shall be sufficient cause for rejection of water under test.
- 1.3 Water for curing mortar, concrete or masonry should not be too acidic or too alkaline. It shall be free of elements which significantly affect the hydration reaction or otherwise interfere with the hardening of mortar or concrete during curing or those which produce objectionable stains or other unsightly deposits on concrete or mortar surfaces.
- 1.4 Hard and bitter water shall not be used for curing.
- 1.5 Potable water will be generally found suitable for curing mortar or concrete.

### M-2 LIME:

- 2.1 Lime shall be hydraulic lime as per I.S. 712-1973. Necessary tests shall be carried out as per I.S. 6932 (Parts I to X) 1973.
- 2.2 The following field tests for limes are to carried out ---
  - a] A very rough idea can be formed about the type of lime by its visual examination i.e. fat lime bears pure white color, lime in form of porous lumps of dirty white color, indicates quick lime, and solid lumps the unburnt lime stone.
  - b] Acid tests for determining the carbonate content in lime. Excessive amount of impurities and rough determination of class of lime.
- 2.3 Storage shall comply with I.S. 712-1973. The slaked lime, if stored, shall be kept in a weather proof and damp proof shed with impervious floor and sides to protect it against rain, moisture, weather and extraneous materials mixing with it. All lime that has been damaged in any way shall be rejected and all rejected materials shall be removed from site of work.
- 2.4 Field testing shall be done according to I.S. 162-1974 to show the acceptability of materials.

### M-3 CEMENT :

- 3.1 Cement shall be Sulphate Resistant Cement conforming to IS : 12330, ordinary Portland slag cement as per I.S. 269-1976 or Portland slag cement as per I.S.455-1976.
- 3.2 Testing of Cement : It should be specifically noted that the cement brought by the contractor at site of work shall be used after the same is tested at the approved laboratory as per the direction of the Engineer-in-charge. Such approved laboratory may be located at Bhavnagar, Baroda, Ahmedabad or Mumbai. All the charges for transport and testing of the samples shall have to be borne by the contractor. The frequency of testing of such materials shall be in accordance to the relevant Indian standard as directed by the Engineer-in-charge.

### M-3A White Cement:

The white cement shall conform to I.S.,80412"-E 1978.

#### **M-4 SAND :**

4.1 Sand shall be natural sand, clean, well graded, hard strong, durable and gritty particles free from injurious of dust, clay, kankar nodules, soft or flaky particles shale, alkali salts, organic matter, loam, mica or other deleterious substances and shall be got approved from the Engineer-in-charge. The sand shall not contain more than 8 percent of silt as determined by field test. If necessary the sand shall be washed to make it clean.

#### 4.2 COARSE SAND :

The fineness modulus of coarse sand shall not be less than 2.5 and shall not exceed 3.0. The sieve analysis of coarse shall be as under :

I. S. Sieve Designation	Percentage by weight passing through sieve	I. S. Sieve Designation	Percentage Passing through sieve
4.75 mm	100	600 Micron	30-100
2.36 mm	90-100	300 Micron	5-70
1.18 mm	70-100	150 Micron	0-50

#### 4.3 FINE SAND :

The fineness modulus shall not exceed 1.0. The sieve analysis of fine sand shall be as under :

I. S. Sieve Designation	Percentage by weight passing through sieve	I. S. Sieve Designation	Percentage Passing through sieve
4.75 mm	100	600 Micron	40-85
2.36 mm	100	300 Micron	5-50
1.18 mm	75-100	150 Micron	0-10

#### **M-5 STONE GRIT :**

5.1 Grit shall consist of crushed or broken stone and be hard, strong dense, durable, clean, of proper gradation and free from skin or coating likely to prevent proper adhesion of mortar. Grit shall for as possible flaky elongated pieces shall be avoided.

It shall generally comply with the provisions of I. S. 383-1970. Unless special stone of particular quarried is mentioned. Grit special stone of particular quarries is mentioned. Grit shall be obtained from the best black trap or equivalent hard stone as approved by the Engineer - in - charge. The grit shall have no deleterious reaction with cement.

5.2 The grit shall conform to the following gradation as per sieve analysis :

I. S. Sieve Designation	Percentage passing through sieve	I. S. Sieve Designation	Percentage Passing through sieve
12.50	100%	4.75	0.20%
10.00	85 – 100%	2.36	0.25%

5.3 The crushing strength of grit will be such as to allow the concrete in which it is used to build up the specified strength of concrete.

5.4 The necessary tests for grit shall be carried out as per the requirements of I. S. 2386 (Parts I to VIII) 1963, as per instruction of the Engineer-in-charge. The necessity of test will be decided by the Engineer-in-charge.



**M-5A STONE COARSE AGGREGATE FOR NOMINAL MIX CONCRETE :**

- 5A.1 Coarse aggregate shall be of machine crushed stone of black trap or equivalent and be hard, strong, dense, durable, clean and free from skin and coating likely to prevent proper adhesion of mortar.
- 5A.2 The aggregate shall generally be cubical in shape. Unless special stones of particular quarries are mentioned, Aggregates shall be machine crushed from the best black trap or equivalent hard stone as approved. Aggregate shall have no deleterious reaction with cement. The size of the coarse aggregate for plain cement concrete and ordinary reinforced cement concrete shall generally be as per the table given below. However in case of reinforcement cement concrete the maximum limit may be restricted to 6 mm less than the minimum lateral clear distance between bars of 6 mm. less than the cover whichever is smaller.

**TABLE**

I. S. Sieve Designation	Percentage passing for single sized aggregates of nominal size			I. S. Sieve Designation	Percentage passing for single sized aggregates of nominal size		
	40 mm	20 mm	16 mm		40 mm	20 mm	16 mm
80 mm	-	-	-	12.5 mm	-	-	-
63 mm	100	-	-	10.0 mm	0.5	0.20	0.30
40 mm	85-100	100	-	4.74 mm	-	0.50	0.50
20 mm	0-20	85-100	100	2.35 mm	-	-	-
16 mm	-	-	-	85-100	-	-	-

NOTE :- The percentage may be varied by the Engineer-in-charge when considered necessary for obtaining better density and strength of concrete.

- 5A.3 The grading test shall be taken in the beginning and at the change of source of materials. The necessary tests indicated in I.S. 383-1970 I. S. 456-1978 shall have to be carried out to ensure the acceptability. The aggregates shall be stored separately and handled in such a manner as to prevent the inter mixed on different aggregates. If the aggregates are covered with dust, they shall be washed with water to make them clean.

**M-5B BLACK TRAP OR EQUIVALENT HARD STONE COARSE :**

- 5B.1 Aggregate for Design Mix concrete : Coarse aggregate shall be of machine crushed stone of black trap or equivalent hard stone and be hard, strong, dense, durable clean and free from skin and coating likely to prevent proper adhesion of mortar.
- 5B.2 The aggregates shall generally be cubical in shape. Unless special stones of particular quarries are mentioned, aggregates shall be machine crushed from the best, black trap or equivalent hard stones as approved. Aggregate shall have no deleterious reaction with cement.
- 5B.3 The necessary tests indicated in I. S. 383-1970 and I.S.456-1978 shall have to be carried out to ensure the acceptability of the material.
- 5B.4 If aggregate is covered with dust it shall be washed with water to make it clean.

**M-6 LIME MORTAR:**

- 6.1 LIME: Shall conform to specification M-2. WATER: Water shall conform to specification M-1. SAND : Sand shall conform to specification M-4.
- 6.2 PROPORTION OF MIX: Mortar shall consist of such proportions of slaked lime and sand as may be specified in the item. The slaked lime and shall be measured by volume.

- 6.3 PREPARATION OF MORTAR : Lime mortar shall be prepared by wet process as per I.S. 1625-1971. Power driven mill shall be used for preparation of lime mortar. The slaked lime shall be placed in the mill in an even layer and ground for 180 revolutions with sufficient water. Water shall be added as required during grinding (care being taken not to add more water) that will bring the mixed material to a consistency of stiff paste. Thoroughly wetted sand shall then be added evenly and the mixture ground for another 180 revolutions.
- 6.4 STORAGE : Mortar shall always be kept damp, protected from sun and rain till used up, covering it by tarpaulin or open sheds.
- 6.5 USE: All mortar shall be used as soon as possible after grinding. It should be used on the day on which it is prepared. But in no case mortar made earlier than 36 hours shall be permitted for use.

#### **M-7 CEMENT MORTAR :**

- 7.1 Water shall conform to specification M-1. Cement shall conform to specification M-3. Sand shall conform to M-5.
- 7.2 PROPORTION OF MIX: 11.2.1 Cement and sand shall be mixed to specified proportions, sand being measured by measuring boxes. The proportion of cement shall be by volume on the basis of 50 Kg./Bag of cement being equal to 0.0342 cu.m.  
The mortar may be hand mixed or machine mixed as directed.
- 7.3 PREPARATION OF MORTAR : 11.3.1 In hand mixed mortar, cement and sand in the specified proportions shall be thoroughly mixed dry on a clean impervious platform by turning over at least 3 times or more till a homogeneous mixture of uniform colour is obtained. Mixing platform shall be so arranged that no deleterious extraneous material shall get mixed with mortar or mortar shall flow out. While mixing, the water shall be gradually added and thoroughly mixed to form a stiff plastic mass of uniform colour so that each particle of sand shall be completely covered with a film of wet cement. The water cement ratio shall be adopted as directed.
- 7.4 The mortar so prepared shall be used within 30 minutes of adding water. Only such quantity of mortar shall be prepared as can be used within 30 minutes.

#### **M-8 BRICK BATS AGGREGATE :**

- 8.1 Brick bat aggregate shall be broken from well burnt or slightly over burnt and dense bricks. It shall be homogeneous in texture, roughly cubical in shape, clean and free from dirt of any other foreign material. The brick bats shall be of 40 mm to 50 mm size unless otherwise specified in the item. The under burnt or over burnt brick bats shall not be allowed.
- 8.2 The brick bats shall be measured by volume by suitable boxes as directed.

#### **M-9 BRICKS :**

- 9.1 The bricks shall be hard or machine molded and made from suitable clay and kiln burnt. They shall be free from cracks and flaws and nodules of free lime. They shall have smooth rectangular faces with sharp corners and shall be of uniform colour. The bricks shall be moulded with a frog of 100 mm x 40 mm and 10 mm to 20 mm deep on one of its flat sides. The bricks shall not break when thrown on the ground from a height of 600 mm.
- 9.2 The size of modular bricks shall be 190 mm x 90 mm.
- 9.3 The size of the conventional bricks shall be as under :
- 3"    3"

( 9" x 4<sup>---</sup> x 2<sup>---</sup> ) 225 x 110 x 25 mm.  
4 4

- 9.4 Only bricks of one standard size shall be used on one work. The following tolerance shall be permitted in the conventional size adopted in a particular work.

Length : = 1/8" (3.0 mm) Width : = 1/16" (1.50 mm)

Height : = 1/16" (1.50 mm)

- 9.5 The crushing strength of the bricks shall not be less than 35 Kg/Sq.cm. The average water absorption shall not be more than 20 percent by weight. Necessary tests for crushing strength and water absorption etc. shall be carried out as per I.S. 3495 (Part-I to IV) - 1976.

#### **M-10 STONE:**

- 10.1 The stone shall be of the specified variety such as Granite/ Trap stone/Quartzite or any other type of good hard stones. The stones shall be obtained only from the approved quarry and shall be hard, sound, durable and free from defects like cavities, cracks, sand holes, flaws, injurious veins, patches of loose or soft materials etc. and weathered portions and other structural defects or imperfections tending to affect their soundness and strength. The stone with round surface shall not be more than 5% of dry weight. When tested in accordance with I.S. 1134-1974. The minimum crushing of the strength of the stone shall be 200 Kg./Sq.Cm. unless otherwise specified.
- 10.2 The samples of the stone to be used shall be got approved before the work is started.
- 10.3 The khanki facing stone shall be dressed by chisel as specified in the item for khanki facing in required shape and size. The face of the stone shall be so dressed that the bushing on the exposed face shall not project by more than 40 mm. from the general wall surface and on face to be plastered it shall not project by more than 19 mm nor shall it have depressions more than 10 mm from the average wall surface.

#### **M-11 HIGH YIELD STRENGTH STEEL DEFORMED BARS :**

- 11.1 Mild steel bars reinforcement for R.C.C. work shall conform to I.S, 432 (Part-II) 1966 and shall be of tested quality. It shall also comply with relevant part of I.S. 456- 1978.
- 11.2 All the reinforcement shall be clean and free from dirt, paint, grease, mill scale or loose or thick rust at the time of placing.
- 11.3 For the purpose of payment, the bar shall be measured correct up to 100 mm length and weight payable worked out as per the rate specified below:
- |                         |                          |
|-------------------------|--------------------------|
| i) 6 mm 0.22 Kg/Rmt.    | viii) 20 mm 2.47 Kg/Rmt. |
| ii) 8 mm 0.39 Kg/Rmt    | ix) 22mm 2.98 Kg/Rmt.    |
| iii) 10mm 0.62 Kg/Rmt.  | x) 25 mm 3.85 Kg/Rmt.    |
| iv) 12 mm 0.89 Kg/Rmt.  | xi) 28 mm 4.83 Kg/Rmt.   |
| v) 14 mm 1.21 Kg/Rmt.   | xii) 32 mm 6.31 Kg/Rmt.  |
| vi) 16 mm 1.58 Kg/Rmt.  | xiii) 36 mm 7.31 Kg/Rmt  |
| vii) 18 mm 2.00 Kg/Rmt. | xiv) 40 mm 9.86 Kg/Rmt   |

#### **M-12 High Yield Strength Steel Deformed Bars [CRS - Fe 500]:**

- 12.1 High yield strength steel deformed bars shall be either cold twisted or hot rolled and shall conform to I.S. 1786-1985. CRS - Fe 500 conforming the test as described for ultimate tensile strength, bend tests and elongation tests. Steel shall be tested in approved laboratories. To samples should be

taken by the engineer in charge in presence of contractor or his authorized representative. One sample shall be got tested and other sample shall be retained by making clear identification in the sample by the engineer in charge so as to identify at a later date. Cost of testing shall be borne by the contractor.

- 12.2 Reinforcement shall be CTD of high strength deformed corrosion resistant (CRS) bars as per IS:1786-1985-Fe500. Wire mesh or fabric shall be in accordance with IS:456. Substitution of reinforcement will not be permitted except upon written approval from engineer in charge.

All reinforcement and structural steel required for construction, erection and other allied job shall be procured by the contractor at his own cost. All the reinforcement steel to be used for the RCC work for the proposed water treatment plant at all levels, shall be CRS (Corrosion Resistant Steel) type of Fe 500 Grade conforming to IS:1786 (Latest addition). The Manufacturer company shall only be RINL, SAIL, TATA, JSW Steel Ltd or Electrotherm(i) Ltd. The steel shall be purchased by the contractor directly from these manufacturers or from their authorized local dealer / distributor. In case of unavailability of steel from these manufacturers, steel may be purchased from other brands purchased/approved by Municipal Store but only after written approval from Engineer-in-charge, SMC.

If JSW or Electrotherm steel is to be used then contractor has to produce test certificate for said project named from time to time & as asked by the engineer in charge. However, Contractor has to take prior approval from engineer in charge before procurement of same.

### 12.3 STORAGE

- a. The reinforcement shall not be kept in direct contact with the ground but stacked on the top of an arrangement of timber sleepers or the like.
- b. If the reinforcing rods have to be stored for a long duration, they shall be coated with cement wash before stacking and/or be kept under cover or stored as directed by the engineer in charge.
- c. Fabricated reinforcement shall be carefully stored to prevent damage, distortion corrosion and deterioration.
- d. It should be seen that reinforcement will not be exposed to direct sunlight and preventive measures should be taken for the same.

### 12.4 Quality

All reinforcement shall be clean free from grease, oil paint, dirt, loose mill scale, loose rust, dust, bituminous materials or any other substances that will destroy or reduce the bond. All rods should be thoroughly cleaned before being fabricated. Pitted and defective rods shall not be used. No welding is approved the works shall be allowed unless approved by engineer in charge. If welding is approved the works shall be carried out as per IS: 1786-Fe500 according to the best modern practices and as directed by the engineer in charge. In all cases of important connections, tests shall be made to prove that the joints are of full strength of bars welded. Special precautions as specified by the Engineer in charge shall be taken in the welding of cold works reinforcing bars and bars other than mild steel.

- 12.5 Other provision and requirements shall conform to specification No. M-11 for Mild Steel bars.

### **M-13 High Tensile Steel Wires:**

- 13.1 The high tensile wires for use in pre-stressed concrete shall conform to I.S. 2090- 1962.
- 13.2 The tensile strength of the high tensile steel bars shall be as specified in the item. In absence of the given strength, minimum strength shall be taken as per Para. 6-1 or the I.S. 1785-1962. Testing

shall be done as per I.S. requirements.

- 13.3 The high tensile steel shall be free from loose mill scale, rust, oil, grease or any other harmful matter. Cleaning of steel bars may be carried out by immersion in solvent solution, wire brushing or passing through a pressure box containing carborundum.
- 13.4 The high tensile wire shall be obtained from manufacturers in coils having diameter not less than 350 times the diameter of wire itself so that wire springs back straight on being uncoiled.

**M-14 MILD STEEL BINDING WIRE:**

- 14.1 The mild steel wire shall be of 1.63 mm or 1.22 mm (16 or 18 gauge) diameter and shall conform to I.S. 280-1972.
- 14.2 The use of black wire will be permitted for binding reinforcement bars. It shall be free from rust, oil, paint, grease, loose mill scale or any other undesirable coating which may prevent adhesion of cement mortar.

**M-15 STRUCTURE STEEL :**

- 15.1 All structural steel conform to I.S. 226 - 1965. The steel shall be free from the defects mentioned in I.S. 226-1975 and shall have a smooth finish. The material shall be free from loose mill scale, rust pits or other defects affecting the strength and durability. Rivet bars shall conform to I.S. 1148-1973.
- 15.2 When the steel is supplied by the contractor test certificate of the manufacturers shall be obtained according to I.S. 226-1975 and other relevant Indian Standards.

**M-16 SHUTTERING :**

- 16.1 The shuttering shall be either of wooden planking of 30 mm. minimum thickness with or without steel lining or of steel plates stiffened by steel angles. The shuttering shall be supported on battens and beams and props of vertical bullies properly cross braced together so as to make the centering rigid. In places of bullie props, brick pillar of adequate section built in mud mortar may be used.
- 16.2 The form work shall be sufficiently strong and shall have camber, so that it assumes correct shape after deposition of the concrete and shall be able to resist forces caused by vibration of live load of men working over it and other incidental loads associated with it. The shuttering shall have smooth and even surface and its joints shall not permit leakage of cement grout.
- 16.3 If at any stage of work during or after placing concrete in the structure, the form sags or bulges out beyond the required shape of the structure, the concrete shall be removed and work redone with fresh concrete and adequately rigid form work. The complete form work shall be got inspected by and got approved from the Engineer-in-charge, before the reinforcement bars are placed in position.
- 16.4 The props shall consist of bullies having 100 mm minimum diameter measured at mid length and 80 mm at thin end and shall be placed as per design requirement. These shall rest squarely on wooden sole plates 40 mm thick and minimum bearing area of 0.10 Sq.m. laid on sufficiently hard base.
- 16.5 Double wedges shall further be provided between the sole plate and the wooden props so as to facilitate tightening and easing of shuttering without jerking the concrete.
- 16.6 The timber used in shuttering shall not be so dry as to absorb water from concrete and swell or bulge nor so wet to shrink after erection. The timber shall be properly sawn and planned on the

sides and the surface coming in contact with concrete. Wooden form work with metal sheet lining or steel plates stiffened by steel angles shall be permitted.

- 16.7 As far as practicable, clamps shall be used to hold the forms together and use of nails and spikes avoided.
- 16.8 The surface of timber shuttering that would come in contact with concrete shall be well wetted and coated with soap solution before the concreting is done. Alternatively coat of raw linseed oil or oil of approved manufacture may be applied in place of soap solution. In case of steel shuttering either soap solution or raw linseed oil shall be applied after thoroughly cleaning the surface. Under no circumstances black or burnt oil shall be permitted.
- 16.9 The shuttering for beams and slabs shall have camber of 4 mm per meter (1 in 250) or as directed by the Engineer-in-charge so as to offset of subsequent deflection for cantilevers the camber at free end shall be 1/50 of the projected length or as directed by the Engineer-in-charge.

**M-17 C.I. Steps :/ Poly propylene heavy duty steps**

- 17.1 Providing and fixing in concrete or brick wall C.I. steps of required length & width as per specifications etc. complete.
- 17.2 C.I. Steps for MH shall be as per IS:5455. It shall be clean, well-cast and shall be free from oil and sand holes wrapping etc. The C.I. steps shall be heavy duty type having size 300 x 150 x 25 mm portion of the step which projects from the wall of the wall/ wet well shall have a raised Chequer design to provide an adequate non-slip grip. Minimum weight of each step be as per I.S. The step shall be coated with approved bituminous paint. Poly propylene heavy duty steps should be provided with permission of engineer in charge.

**M-18 Galvanized Iron Sheets:**

- 18.1 The galvanized iron sheets shall be plain or corrugated sheets of gauge as specified in Description. The G. I. Sheets shall conform to I. S. 277 – 1992. The sheets shall be undamaged in carriage and handling either by rubbing off of zinc coating or otherwise. They shall have clean and bright surface and shall be free from dents, bends, holes, rust or white powdery deposit.
- 18.2 The length and width of G. I. sheets shall be as directed as per site condition.

**M-18A G. I. Valleys Gutter, Ridges:**

- 18-A.1 The G. I. Ridge and hips shall be of plain galvanized sheets class-3 of the thickness as specified in Description. These shall be 600 mm width and properly bent up shape without damage to the sheets in process of bending.
- 18-A.2 Valleys gutters and flashings shall be also of galvanized sheet of thickness as specified in Description. Valleys shall be over all. They shall be bent to the required shape without damage to the sheet in the process of bending.

**M-19 Teak Wood:**

- 19.1 The teak wood shall be of good quality as required for the Description to be executed. When the kind of wood is not specifically mentioned, good Indian teak wood as approved shall be used.
- 19.2 Teak wood shall generally be free from large, loose, dead or cluster knots, flaw, warps, twists, shakes, bends or any other defects. It shall generally be uniform in substance and of straight fibers as far as possible. It shall be free from rot, decay, harmful fungi and other defects of harmful nature, which will affect the strength, durability or its usefulness for the purpose for which it is required, the

colour shall be uniform as far as possible, any effort like painting, using any adhesive or resinous materials made to hide the defects shall render the pieces liable to rejection by the Engineer-in-charge.

19.3 All scantlings, planks etc. shall be sawn in straight lines and planes in the direction of grains and of uniform thickness.

19.4 The tolerances in the dimensions shall be allowed at the rate of 1.5 mm per face to be planed

19.5 First Class Teak Wood :

First class teak wood shall have no individual hard and sound knots, more than 6 sq.cm. in size and the aggregates area of such knots shall not be more than 1% of area of piece. The timber shall be closed gained.

Second Class Teak Wood:

No individual hard and sound knots shall be more than 15 sq cm in size and aggregates area of such knots shall not exceed 2% of the area of piece.

#### **M-19A Non – Teak Wood:**

M-19A.1 The non- teak wood shall be chemically treated, seasoned as per I.S. Specification and of good quality. The types of wood shall be got approved before collecting the same on site Fabrications of wooden members shall be started only after approval. For this purpose wood of Bio, Kalai, Sires, Saded, Behda, Jamun, Sisoo will be used for door frames whereas only Kalai, Siras, Halda, Kalam etc will be permitting for shutters after proper seasoning and chemical treatment.

M-19A.2 The non teak wood shall be free large, loose dead of cluster knots, flows, shakes, warps bends, or any other defect. It shall be uniform in substance and of straight fibers as per as possible. It shall be free from rots, decay, harmful fungi and other defects of similar nature which will affect the strength, durability or its usefulness for the purpose for which it is required. The colour of the wood shall be uniform as far as possible. The scantalings, planks etc. shall be sawn in straight lines and planes in the direction of grain and of uniform thickness.

M-19A.3 The department will use the agency to produce a certificate from the Forest Department in the event of a dispute and the decision of Department shall be final and binding to the contractor. The tolerance in the dimension shall be allowed at 1.5 mm. per face to be planed.

#### **M-20 Wooden Flush Doors Hutters (Solid Core):**

20.1 The solid core type flush door shutters shall be of decorative or non – decorative types as specified in the drawing. The size and thickness of the shatter shall be as specified in drawing s or directed. The timber species for core shall be used as per I.S. 2202 – (Part –I)-1991. The timber shall be free from decay and insect attack. Knots and knot holes less than half the width of cross- section of the members, pitch streaks an harmless pin holes shall be permissible expect in the exposed edge of the core members. The commercial plywood, cross bands shall conform to I.S. 303 – 1998.

20.2 The face panel of the shutter shall be formed by gluing by the hot press process on both faces of the core with either plywood or cross bands, or face veneers. The lapping, rebating opening of glazing, Venetian etc, shall be provided if specified in the drawing.

All edges of the door shutters shall be square. The shutters shall be free from twist or warp in its plan, both faces of the shutters shall be sand papered to smooth even texture.

The shutters shall be tested for ---

- i) End immersion Test: The test shall be carried out as per I.S. 2202 (Part – I) 1991. There shall be no delamination at the end of the test.
- ii) Knife Test: The face panel when test in accordance with I.S. 1659 – 1990 shall pass the test.
- iii) Glue adhesion Test: the flush door shall be tested for glue adhesive test in accordance with I.S.2202 (Part – I) – 1991. The shutters shall be considered to have passed the test if no delamination occurs in the glue lines in the Plywood and if no single delamination more than 80 mm. in length and more than 3mm. in depth have occurred in the assembly glue lines between the plywood face and the style and rail. Delamination at the corner shall be measured continuously around the corner. Delamination at the knots knot, whole and other permissible wood defects shall not be considered in assessing the sample.

20.3 The tolerance in size of solid core type flush door as under: -

In nominal thickness # 1.2 mm. In nominal height # 3 mm. The thickness of the shutters shall be uniform throughout with a permissible variation of not more than 0.8 mm. when measuring at any two points.

#### **M-21 Aluminum Doors, Windows, Ventilators:**

- 21.1 Aluminum alloy used in the manufacture of extruded window section shall conform to I.S. designation HEA – WP of I.S: 733 – 1991 and also to I.S. Designation WVG – WP of I. S.: 1285 – 1991. The sections shall be as specified the drawing and design. The fabrication shall be done as directed.
- 21.2 The hinges shall be cast or excluded aluminum hinges of same type as in window but or large size.
- 21.3 The hinges shall normally be of 50 mm projecting type non projecting type of hinges may also be used if directed. The handles of door shall be of specified design. A suitable lock for the door operable either from outside shall be provided. In double shutter door, the first closing shall have a concealed aluminum alloy bolt at top and bottom.

#### **M-22 Rolling Shutters:**

- 22.1 The rolling shutters shall conform to I. S. 6248 – 1991. Rolling shutters shall be supplied of specified type with accessories. The size of the rolling shutters shall be specified in the drawings. The shutters shall be constructed with interlocking lath section formed from cold rolled steel strips not less than 0.9 mm thick and 80 mm. wide for shutters 3.5 m. Width not less than 1.25 mm. thick and 80 mm. Wide for shutters 3.5 m. in width and above unless otherwise specified.
- 22.2 Guide channels shall be of mild steel deep channels section and of rolled pressed or built up (fabricated) joint less construction. The thickness of sheet used shall be not less than 3.15 mm.
- 22.3 Hood covers shall be made of M.S sheets not less than 0.92 mm thick. For shutters having width 3.5 mts. and above, the thickness of M.S. sheet for the hood cover shall be less than 1.25 mm.
- 22.4 The spring shall be of best quality and shall be manufactured from tested high tensile spring steel wore or strip of adequate strength to balance the shutters in position. The spring pipe shaft etc. shall be supported on strong M. S. or malleable C. I. brackets. The brackets shall be fixed on the or under lintel as specified with rawly Plugs and a screw bolts etc.
- 22.5 The rolling shutters shall be of self rolling type up to 8 sq. m. clear area without ball bearing and up to 12 sqm Clear area with ball bearing. If the rolling shutters are of larger then gear operated type shutter shall be used.
- 22.6 The locking arrangement shall be provided at the bottom of shutter at both ends. The shutters shall be opened from outside.



22.7 The shutters shall be completed with door suspension, shafts, locking arrangement, pulling hooks, handles and other accessories.

**M-23 Collapsible Steel Gate:**

23.1 The collapsible steel shall be in one or two leaves and size as per approved drawings or as specified. The gate shall be fabricated from best quality mild steel channels, flats etc. Either steel pulleys or ball bearing shall provide in every double channel. Unless otherwise specified the particulars of collapsible gate shall be as under ---

- i) Pickets: These shall be 20mm. M.S. channels of heavy sections unless otherwise shown on drawings. The distance centre to centre of Pickets shall be 12 cms. With an opening of 10 cm.
- ii) Pivoted M. S. flats shall be 20 mm. X 6 mm.
- iii) Top and bottom guides shall be from toe or flats iron of approved size.
- iv) The fittings like stoppers, fixing hold fasts, locking cleats, brass handles and cast iron rollers shall be of approved design and size.

**M-24 Plywood:**

24.1 The Plywood for general purpose shall conform I.S. 303 – 1998. Plywood is made by cementing together thin boards or sheets of wood into panels. There are always an odd number of layers 3, 3, 7, 9, Ply etc. The plies are placed so that the grain of each layer is at right angles to the grain in the adjacent layers.

24.2 The chief advantage of plywood over a single board of the same thickness is the more uniform strength of the Plywood along the length and width of the Plywood and greater resistance to cracking and slitting with change in moisture content.

24.3 Usually synthetic resins are used for gluing. Phenolic resins are usually cured in a hot press which compresses and simultaneously heats the plies between hot plates which maintain a temperature of 90-degree C. to 140-degree C. and a pressure of 11 to 14 kg./Sq.cm on the wood. The time of heating may be anything from 2 to 60 minutes depending upon thickness.

24.4 When water glue are used the wood absorbs so much water that the finished plywood must be dried carefully, when synthetic resins are used as adhesive the finished plywood must be exposed to atmosphere of controlled humidity until the proper amount of moisture has been absorbed.

24.5 According to I. S : 303 – 1998 the plywood for general purpose shall be three grades namely BWR, WWR and CWR depending upon the adhesives used for bounding the veneers and it will be further classified into six types namely AA, AB, AC, BB, BC, and CC based on the quality of the two faces, each face being of three kinds namely A, B, and C. After pressing, the finishing plywood should be reconditioned to a moisture content not less than 8 percent and not more than 16 percent.

**24.6 THICKNESS OF PLYWOOD BOARDS**

Board	Thickness	Board	Thickness
3 Ply	3 mm	7 Ply	9 mm
	4 mm		13 mm
	5 mm		16 mm
	6 mm	9 Ply	13 mm
5 Ply	5 mm		16 mm
	6 mm		19 mm
	8 mm	11 Ply	19 mm

	9 mm		22 mm
			25 mm

**M-25 Glass:**

- 25.1 All glass shall be of the best quality, free from specks, bubbles, smokes, veins air holes blisters and other defects. The kind of glass to be used shall be as mentioned in the Description or specification or in the special provisions or as shown in detailed drawings. Thickness of glass panes shall be uniform. The specification for different kinds of glass shall be as under -----
- 25.2 Sheet Glass:
- 25.2.1 In the absence of any specified thickness or weight in the Description or detailed specifications of the Description of work, sheet glass shall be weighing 7.5 kg./Sq.m. for panes up to 600 mm. X 600 mm.
- 25.2.2 For panes larger than 600 mm. x 600 mm. and up to 800 mm. glass weighing not less than 8.75 kg./Sq.m. shall be used. For bigger panes up to 900 mm. X 900 mm. glass weighing not less than 11.25 kg./sq.m. Shall be used.
- 25.2.3 Sheet glass shall be patent flattened glass of best quality and for glassing and framing purpose shall conform to I. S. 761 – 1993. Sheet glass of the specified colours shall be used, if so shown on detailed drawing or so specified. For important buildings and for panes with any dimensions over 900 mm. Plate glass of specified thickness shall be used.
- 25.3.0 Plate Glass:
- 25.3.1 When Plate glass is specified it shall be “Polished Patent Plate Glass” of best quality. It shall have both the surface ground flat and parallel and polished to obtain clear undisturbed vision and reflection. The plate glass shall be of the thickness, mentioned in the Description or as shown in the detailed drawing or as specified. In the absence of any specified thickness, the thickness of plate glass to be supplied shall be 6 mm. and a tolerance of 0.20 mm. shall be admissible.
- 25.4.0 Obscured Glass:
- 25.4.1 This type of glass transmits light so that vision is partially or almost completely obscured. Glass shall be plain rolled, figured, ribbed or fluted, or frosted glass as may be specified as required. The thickness and type of glass shall be as per details on drawings or as specified or as directed.
- 25.5.0 Wired Glass:
- Glass shall be with wire netting embedded in a sheet of plane glass. Electrically welded 13 mm. Georgian square mesh shall be used. Thickness of glass shall not be less than 6 mm. wired glass shall be of type and thickness as specified.

**M-26 Acrylic Sheets:**

- 26.1 Acrylic sheets shall be of thickness as specified in the Description and of a specified shape and size as the case may be. Panels may be flats or curved. It should be light in weight. It shall be colourless or coloured or opaque as specified in the Description. Colourless sheet shall be as transparent as the finest optical glass. Its light transmission rate shall be about 95%. Transparency shall not be affected for the sheets of larger thickness. It shall be extremely resistant to sunlight, weather and low temperatures. It shall not show any significant yellowing or change in physical properties or loss of light transmission over a longer period of use.
- 26.2 The sheet shall be impact resistant also. Sheets should be available in complete range of standard transparent, translucent and opaque colours. Sheets should be available in complete range of

standard transparent, translucent and opaque colours. Sheets shall be of such quality that they can be cut, bent and jointed as desired. Solution for the joints shall be used as per the requirement of manufacture.

**M-27 Resin Bonded Fiber Glass:**

- 27.1 The resin bonded fiber glass tile or rools shall be of approved make and shall be sizes, thickness and finish as indicated.
- 27.2 For test of material wood thermal insulation blanket I.S. 3144 – 1991 followed.
- 27.3 Insulation wool blanket shall be with the following coverings on one or both sides as indicated.
- (1) Bituminized bessian Kraft paper suitable for use in position where moisture has to be excluded.
  - (2) Hessian cloth or Kraft paper for keeping out dust.
  - (3) G.I wire netting, suitable or surfaces to be plastered over.

**M-28 Fixtures & Fastening:**

General ----

- i) The fixtures and fastenings, that is, butt, hingers, tee and strap hinges, sliding door bolts, tower bolts, door latch, bath-room latch, handles, door stoppers, casement window fasteners, casement stays and ventilator catch shall be made of the metal as specified in the Description or its specifications.
- ii) They shall be of iron, brass, aluminum Chromium plated iron, chromium plated brass, copper oxidized iron, and copper oxidized brass or anodized aluminum as specified.
- iii) The fixtures shall be heavy, medium or light type. The fixtures and fastening shall be smooth finished and shall be such as will ensure ease of operation.
- iv) The samples of fixtures and fastenings shall be got approved as regards quality and shape before providing them in position.
- iv) Brass and anodized aluminum fixtures and fastenings shall be bright finished.

**Hold fasts:**

- i) Hold fasts shall be made from mild steel flat 30 cm. length and one of the hold fasts shall be bent at right angle and two nos. 6 mm. dia. Holes shall be made in it for fixing it to the frame with screws. At the other end, the hold fast shall be forked and bent at right angles in opposite directions.

**Butt Hinges:**

- i) Railway standard heavy type butt hinges shall be used when so specified.
- ii) Tee and strap hinges shall be manufactured from M. S. sheet.

Sliding Door Bolts (Aldrops):

- i) The aldrops as specified in the Description shall be used and shall be got approved.

**Tower Bolts (Barrel Type)**

- i) Tower bolts as specified in the Description shall be used and shall be got approved.

**Door Latch:**

The size of door latch shall be taken as the length of latch.

**Bathroom Latch:**

Bathroom latch shall be similar to tower bolt.

**Handle:**

The size of the handles shall be determined by the inside grip length of the handles. Handles shall have a base plate of length 50 mm. more than size of the handle.

Door Stoppers:

- i) Door stoppers shall be either floor door stopper type or door catch type. Floor stopper shall be of overall size as specified and shall have a rubber cushion.

**Door Catch:**

- i) Door catch shall be fixed at a height of about 900 mm. from the floor level such that one part of the catch is fitted on the inside of the shutter and other part is fixed in the wall with necessary wooden plug arrangements for appropriate fixate. The catch shall be fixed 20 mm. inside the face of the door for easy operation of catch.

**Wooden Door Stop with Hinge:**

- i) Wooden doors stop of size 100 mm. X 60 mm. X 40 mm. shall be fixed on the door frame with a hinge of 75 mm. size and at a height of 900mm. from the floor level. The wooden doorstop shall be provided with 3 coats of approved oil paint.

**Casement Window Fastener**

Casement window fastener for single lead window shutter shall be left or right-handed as directed.

**Casement Stays (Straigot Peg. Stay):**

- i) The stays shall be made from a channel section having three holes at appropriate position so that the window can be opened either fully or partially as directed.

Size of the stay shall be 250 mm. to 300 mm. as directed.

**Ventilator Catch:**

- i) The Pattern and shape of the catch shall be as approved.

**Pivot:**

- i) The base and socket Plate shall be made minimum 3 mm. thick plates and projected pivot shall not be less than 12 mm. dia. and 12 mm. lengths and shall be firmly riveted to the base plate case of iron pivot and in single piece base in the case of brass pivot.

**M-29 Paints:**

**29.1 Oil Paints:**

Oil paints shall be of the specified color and shape, and as approved. The ready mixed paints shall only be used. However, if ready mixed paint or specified shade or tint is not available white ready mixed paint with approved strainer will be allowed. In such a case, the contractor shall ensure that the shade of the paint so allowed shall be uniform.

All the paints shall need with the following general requirements.

- i) Paint shall not show excessive setting in a freshly opened full can and shall easily be redispersed with paddle to a smooth homogeneous state. The paint shall show no curdling, leivering, caking or colour separation and shall be free from lumps and skins.

The paint as received shall brush easily, possess good leveling properties and show no running or sagging tendencies.

The paint shall not skin within 48 hours in three quarters filled closed container.

The paint shall dry to a smooth uniform finish free from roughness, grit unevenness and other imperfections.

Ready mixed paint shall be used exactly as received from the manufacturers and generally according to their instructions and without any admixtures whatsoever.

**29.2 Enamel Paints:**

The enamel paint shall satisfy in general requirements as mentioned in specification of oil paints. Enamel paints shall conform to I.S. 2933 – 1975.

**M-30 Marble Chips For Marble Mosaic Terrazzo:**

- 30.1 The marble chips shall be of approved quality and shades. It shall be hard, sound, dense and homogeneous in texture with crystalline and coarse grains. It shall be uniform in colour and free from strains, cracks, decay and weathering.
- 30.2 The size of various colours of marble chips ranging from the smallest up to 20 mm. shall be used where the thickness of top wearing layers is 6 mm. in size. The marble chips of approved quality and colours only as per grading as decided by the Engineer-in-charge shall be used for marble mosaic tiles or works.
- 30.3 The marble chips shall be machine crushed. They shall be free from foreign matter, dust etc. Except as above the chips shall conform to I.S. 2114 – 1990.

**M-31 Chequered Tiles:**

- 31.1 Chequered tiles shall be plain cement tiles or marble mosaic tiles. The former shall have the same specification as per (A) above and the latter as per marble mosaic tiles as per (C) except as mentioned below
- 31.2 The tiles shall be of nominal size of 250 mm. X 250 mm. or as specified. The centre-to-centre distance of the chequer shall not less than 25mm. and not more than 50mm. The overall thickness to the tile shall be 22 mm.
- 31.3 The grooves in the chequers shall be uniform and straight. The depth of the grooves shall not be less than 3mm. The chequered tiles shall be plain, coloured or mosaic as specified. The thickness of the upper layer measured from the tops of the chequers shall not be less than 6mm. The tiles shall be given the first grinding with machine before delivery to site.
- 31.4 Tiles shall conform to relevant I.S. 1237- 1990.

**M-32 Polished Kotah Stones:**

- 32.1 Polish kotah stone shall have the same specifications as per rough kotah stone except as mentioned below.
- 32.2 The stone shall have machine polished smooth surface. When brought on site, the stones shall be single polished or double polished depending upon its use. The stones for paving shall generally be single polished. The stones to be used for dado, skirting, platforms, sink, veneering, sills, steps etc. where machine polishing after the stones are fixed in situ is not possible shall be double polished.

**M-33 White Glazed Tiles:**

- 33.1 The tiles shall be of best quality as approved by the Engineer-in-charge. They shall be flat and true to shape. They shall be free from cracks, crazing, spots, chipped edges and corners. The glazing shall be of uniform shade.
- 33.2 The tiles shall be of nominal size of 150 mm. X 150 mm. X 150 mm. unless otherwise specified. The maximum variation from the stated sizes, other than the thickness of tile, shall be plus or minus

1.5mm. The thickness of the tile shall be 6mm. except as above the tiles shall conform to I. S. 777 – 1988.

**M-34 Galvanised Iron Pipes And Fittings:**

Galvanized iron pipe shall be of the medium type and of required diameter and shall comply with I.S. 1239 – 1990. The specified diameter of the pipes shall refer to the inside diameter of the bore. Clamps, screw and all galvanized iron fittings shall be the standard 'R' or equivalent make.

**M-35 Bib Cock And Stop Cock:**

35.1 A bib cock is a draw off tap with a horizontal inlet and a free outlet. A stop cock is a valve with a suitable means of connection for insertion in a pipe line for controlling or stopping the flow.

35.2 They shall be of screw down type and or brass chromium plated and of diameter as specified in the description of the Description. They shall be polished bright.

35.3 The minimum finished weight of bib cock and stop shall be as given below ---

Dia.	Bib Cock	Dia.	Bib Cock	Stop Cock
8 mm	0.25 Kg.	15 mm.	0.40 Kg.	0.40 Kg.
10 mm	0.30 Kg.	20 mm.	0.75 Kg.	0.75 Kg.

**M-36 GUN METAL WHEEL VALVE:**

36.1 The gun metal wheel valve shall be of approved quality. These shall be of gun metal fitted with wheel and be of gate valve opening full way and of the size as specified. These shall conform to I. S. 778 – 1990.

**M-37 White Glazed Procelain Wash Basin:**

37.1 Wash basin shall be of white porcelain first quality best India make and it shall conform to I.S. 2556– (Part – IV) - 1994 and I. S. 771 – 1992. the size of the wash basin shall be as specified in the Description. The wash basin shall be of one-piece construction with continued over-flow arrangements. All internal angles shall be designed so as to facilitate cleaning. Wash basin shall have single tap hole, or two holes as specified. Each basin shall have circular waste hole which is either rebated or beveled internally with 65mm. dia at top and 10m.depth to suit the waste fitting. The necessary stud slot to receive the bracket on the underside of the basin shall be provided. Basin shall have an internal so a holder recess which shall fully drain into the bowl.

37.2 White glazed pedestal of the quality and colour as that of the basin shall be provided where specified in the Description. It shall be completely recessed at the back for reception of supply and water pipe. It shall be capable of supporting the basin rigidly and adequately and shall be so designed as to make the height from the floor to top of the rim of basin 750 mm. to 800 mm. as directed.

**M-38 European Type Water Closet / With Low Level Flushing**

38.1 The European type of water closet shall be white glazed conforming to I.S. 2556 – 1994 and I.S. 771 -1692.

- 38.2 'S' trap shall be provided as required with water seal not less than 50 mm. The solid plastic seat and cover shall be of the best Indian make conforming to I.S. 2548 – 1996. They shall be made of moulded synthetic materials which shall be tough and hard with high resistance to solvents and shall be free from blisters and other surface defects and shall have chromium Plated brass hinges and rubber of suitable size.

**M-39 Glazed Earthen Ware Sink:**

The glazed earthenware sink shall be of specified size, colour and quality. The sink shall conform to I.S. 771 – Part II-1992. The brackets for sinks shall conform to I. S. 775 – 1990.

The Pipes shall conform to I. S. 1239 – Part-I-1990 and I. S. 404 – 1962. for steel and lead pipes respectively. 32 mm. brass wastes coupling of standards of pattern with brass chain and rubber plug shall be provided with sink.

**M-40 Glazed Earthen Ware Lipped Type Flat Back Urinal / Corner Type Urinal:**

The lipped type of urinal shall be flat back or corner type as specified in the Description and shall conform to I. S. 771 - 1992. It shall be of best Indian make and size as specified and approved by the Engineer-in-charge. The flats back or corner type urinal must be of first-class quality, free from any defects, cracks etc.

**M-41 Cast Iron Flushing Cistern:**

- 41.1 The cast iron flushing cistern shall be of 15 liters capacity. It shall conform to I. S. 774 - 1990. The flushing cistern shall be of best quality free from any defects.

- 41.2 The flushing cistern shall have outlet of 32 mm. diameter. The outlets shall be connected to end pipe of 32 mm. diameter. The lead pipe shall conform to I.S. 404 (Part – I) 1993. For fixing G.I. inlet pipes and overflow pipes 20 mm. dia. inlet and outlet shall be provided. The flushing cistern shall be provided with galvanized iron chain and pull of sufficient length and shall be got approved from the Engineer-in-charge. The cast iron flushing cistern shall be painted with one coat of paints the flushing cistern shall be fixed on C.I. brackets. The brackets shall conform to I.S. 775 – 1990.

**M-42 Flush Cock:**

Half turn flush cock (heavyweight) shall be gun metal chromium plated of diameter as specified in the description of the Description. The flush cock shall conform to relevant Indian Standards.

**M-43 Cast Iron Pipes And Fittings:**

- 43.1 All soil, waste, vent and antisiphonage pipes and fittings shall conform to I. S.1729 – 1991. The Pipes shall have spigot socket ends with head on spigot end. The pipes and fittings shall be true to shape, smooth, cylindrical their inner and outer surfaces being as nearly as practicable concentric. They shall be sound nicely cast and shall be free from cracks, Laps, pin holes or other imperfection shall be neatly dressed and carefully fettled.
- 43.2 The end of Pipes and fitting shall be reasonably square to their axis.
- 43.3 The sand cast iron pipes shall be the diameter as specified in the description and shall be in length of 1.5 M., 1.8 M. & 2.0 M. including socket ends of the pipe unless shorter length are either specified or required at junction etc. The pipes and fittings shall be supplied without ears unless specified or directed otherwise.

43.4 Tolerance: The standard weights and thickness of Pipes shall be as shown in the table below. A tolerance up to minus 10% may however be allowed against these standard weights.

Sr. No.	Nominal Dia. Of bore	Overall Thickness	Weight of Pipe Excluding Ears		
			1.5M. long	1.8M. long	2Mlong
1.	75 mm.	5.0 mm.	12.83 Kg.	16.52 Kg.	18.37 Kg
2.	100 mm.	5.0 mm.	18.14 Kg.	21.67 Kg.	24.15 Kg.
3.	150 mm				
4.	250 mm.				

A tolerance up to minus 15% in thickness and 20 mm. in length will be allowed. For fittings tolerance in lengths shall be plus 25 mm. and minus 10 mm.

The thickness of fittings and their socket and spigot dimensions shall conform to the thickness and dimensions specified for the corresponding sizes of straight pipes. The tolerance in weights and thickness shall be the same as for straight pipe

**M-43A P.V.C. Pipes & Fittings: -**

1. All soil, waste and vent pipes & fittings shall conform to I.S. 4985 – 1988 & I. S. 13592: 1992. The Pipes are provided with an integral rubber ring type socket at one end while the other end in kept plain, smooth & free from burrs. The pipes and fittings shall be true to shape, smooth & cylindrical. They shall be free from cracks, laps, pinholes or other imperfection and shall be nearly dressed and carefully fettled.
2. The P.V.C. Pipes shall be of the diameter as specified in the description and shall be in length of 6.0, 3.0 & 1.8 m including socket ends of the pipe unless shorter length are either specified or required at junction etc. Tolerances on specified length shall be + 10mm and - 0 mm.
3. Rubber real rings for joints Access Doors shall be Manufactured in accordance with IS : 5382 – 1998. There are made out or natural rubber with a shore 'A' hardness of 40 + 5. The mean outside diameter, outside at any point and wall thickness manufactured Plain or with socket shall be as shown in the following table:-

All dimensions in millimeters.

Sr. No.	Nominal / Outside Dia.	Mean outside Diameter.		Outside Diameter at any Point.		Wall thickness	
		Min.	Max.	Min.	Max.	Min.	Max.
1.	75	75.0	75.3	74.1	75.9	3.2	3.8
2.	110	110.0	110.4	108.6	111.4	3.2	3.8

Minimum Wall thickness of sockets on pipes & Dimensions of sliding socket of pipes shall be as shown in following table.

All dimensions in millimeters.

Sr. No.	Nominal / Outside Diameter	Minimum wall thickness of sockets on pipes.		Socket Depth Min.	Mean inside Diam. of socket at Mid-point.	
		S2, Min.	S3, Min.		Min.	Max.
1.	75	2.9	2.4	40.0	75.1	75.3
2.	110	2.9	2.4	48.0	110.1	110.4



The outside diameter of Pipe shall be obtained by the method given in IS : 12235 ( Part – 1 ) – 1998, wall thickness shall be measured by the method given in IS : 12235 ( Part -2 ) 1998.

The Permissible variation between the mean outside diameter & the nominal outside diameter of a pipe shall be positive in the form + x, where x is less than or equal to greater of the following two values.

a) 0.03 mm, and

b) 0.003 X nominal outside diameter- rounded off to the next higher 0.1 mm.

The Permissible variation between the outside diameter at any point (d1) & the nominal outside diameter (de) of a pipe shall not exceed the greater of the following two values.

a) 0.5 mm, and

b) 0.012 de round off to the next higher 0.1

The thickness of fittings and their socket & spigot dimensions shall conform to the thickness and dimensions specified for the corresponding sizes of straight pipes.

#### **M-44 Nahni Trap:**

Nahni trap shall be of PVC Multi floor Nahni trap and shall be sound and free from porosity or other defects which affect serviceability. The thickness of the base metal shall not be less than 6.5 mm. The surface shall be smooth and free from cracks, chips and other flaws or any other kind of defects which affect serviceability. The size of nahni trap shall be as specified and shall be of self-cleansing design.

The nahni trap shall be of quality approved by the Engineer-in-charge and shall generally conform to the relevant Indian Standards.

The nahni trap provided shall be deep seal, minimum 50 mm. except at places where trap with deep seal cannot be accommodated. The cover shall be S.S. jail. Perforated cover shall be provided on the trap of appropriate size

#### **M-45 Gully Trap:**

Gully trap shall conform to I.S 651 -1992. It shall be sound free from defect such as fire cracks or hair cracks. The glaze of the traps shall be free from crazing they shall give a sharp clear note when struck with light hammer. There shall be no broken blisters. The size of the gully trap shall be as specified in the Description.

Each gully trap shall have one C.I. grating of square size corresponding to the dimensions, of inlet of gully trap. It will also have a water tight C.I. cover with frame inside dimensions 300mm. X 300mm. the cover weighting not less than 4.53 Kg and the frame not less than 2.72 kg. The grating cover and frame shall be of shall be sound and good casting and shall have truly square machined seating faces.

#### **M-46 Glazed Stone Ware Pipe And Fittings:**

The pipes and fitting shall be of best quality as approved by the Engineer-in- charge. The pipe shall be best quality manufactured from stone-ware of fire clay, salt glazed thoroughly burnt through the whole thickness, of a close even texture, free from air blows, fire blisters, cracks and other imperfections which affect the serviceability. The inner and outer shall be smooth and perfectly glaze. The pipe shall be capable to withstand pressure of 1.5m lead without showing signs of leakage. The thickness of the wall shall not be less than (1/12)th of the internal dia. The depth of

socket shall not be less than 38 mm. The socket shall be sufficiently large to allow a joint of 6 mm. around the pipes. The pipes shall generally conform to relevant I. S. 651 – 1992.

**M- 47 Wall Peg Rail:**

47.1 The aluminum wall peg rail shall have three aluminum pegs of approved quality and size. It shall be fixed on teakwood plank of size 450 mm. X 7 mm. X 20 mm. the teak wood shall be French polished or oil painted as specified.

**M-48 Asbestos Cement Pipe (A.C. Pipe):**

48.1 The asbestos cement pipe of diameter as specified in the description of the Description shall conform to I. S. 1926 – 1980. Special like bends, shoes cowl, etc. shall conform to relevant Indian Standards. The interior of pipe shall have a smooth finish, regular, surface and regular internal diameter. The tolerance in all dimensions shall be as per I. S. 1926 – Part-I- 1980.

**M-49 Crydon Ball Valve:**

Ball valve of screwed type including polythene float and necessary lever etc. shall be of the size as mentioned in the description of Description and shall conform to I.S. 1703 – 1989.

**M-50 Bitumen Felt For Water Proofing And Damp Proofing:**

50.1 Bitumen felt shall be the fiber base and shall be of type 2, self-finished felt grade -2 and shall conform to I.S. 1322 – 1998.

**M-51 Selected Earth:**

51.1 The selected earth shall be that obtained from excavated material or shall have to be brought from outside as indicated in the Description. If Description does not indicate anything the selected earth shall have to be brought from outside.

51.2 The selected earth shall be good yellow soil and shall be got approved from the Engineer-in-charge. In no case black cotton soil or similar expansive and shrinkable soil shall be used. It shall be clean and free from all rubbish and perishable materials, stones or brick bats. The clods shall be broken to a size of 50 mm. or less. Contractor shall make his own arrangements at his own costs for land for borrowing selected earth. The stacking of materials shall be done as directed by the Engineer-in- charge in such a way as not to interfere with any constructional activities and in proper stacks.

51.3 When excavated material is to be used, only selected stuff got approved from the Engineer-in-charge shall be used. It shall be stacked separately and shall comply with all the requirements of selected earth mentioned above.

**M-52 Crack seal:**

Crack seal manufactured by Chemistic / Chemisol Indian Ltd., is an acrylic base ready application compound.

**M-53 Cast Iron Steps:**

The cast iron steps shall be clean, well-cast and they shall be free from air and sand holes, colds shuts and warping which are likely to impair the utility of the castings. The portion of the step which projects from walls of the manhole shall have a raised required designed above the general plan of

the top surface of the step along the edges of the tread to provide adequate non-slip grip. The steps shall be of dimensions 375 mm x 150 mm x 25 mm with necessary holding arrangement and carting minimum weight of 4.5 Kg. conforming to I.S. 5455 – 1992 or its latest version.

The cast iron steps shall be coated with a material having tar base or a place bituminous composition of cashew-nut shall liquid. The coating shall be smooth and tenacious. It shall not flow when exposed to a temperature of 0-degree C.

**M-54 Vitrified Floor Tiles:**

Vitrified floor ties shall be of the best quality like Granamite or equivalent as approved by the Architect / Consultant and Engineer-in-charge.

They shall be monolithic and available in smooth, mirror polished and anti-skid finishes, in size 24" x 24". They shall have a size tolerance of + / - 0.5%, in length and width and + / - 5% in thickness. Allowable warpage shall be + / -0.2%. Allowable squareness wedging shall be + / -0.5%. Their water absorption rate shall be less than 0.5%. They shall offer hard- working and hard-wearing floors for homes, public building, apartments and airports.

They shall be extremely strong, breaking strength of the tile being 1600 Kg/Sq.cm. flexural strength 200 Kg/Sq.cm. and bonding strength of 2500 KG/Sq.cm. They shall offer good resistance to abrasion, i.e. greater than 100. they shall be scratch resistant, their hardness on the Moh's scale shall be minimum 7. They shall be able to resist thermal shock up to 10 cycles. They shall have bond strength of 2500 Kg/Sq.cm. and shall have 0.60 co-efficient of Friction for the polished / unpolished surfaces. All joints of the slabs shall align in both directions.

**M-55 Stainless Steel Railing:**

The Stainless-Steel railing pipe shall be specified size and quality. The S.S. railing pipe shall conform to steel of grade designation 312 conforming to IS 13983.

The S.S. pipe shall be of 50 mm dia and of 16-gauge (1.62 mm) thickness with S.S. plate of 2.00 mm thickness.

The S.S. rod and flat shall be of steel grade AISI 312.

**M-56 Acrylic Emulsion Paints:**

It shall be from ICI, Nerolac, Asian Paints, Berger, as approved by the Engineer in charge and Engineer-in-Charge. It shall conform to the relevant IS codes.

It shall be used on both interiors and exteriors, on all different types of plaster, wooden surfaces, stone, brickwork, asbestos cement sheets, hard and soft boards, etc. It shall render rich smooth finish and shall provide a tough film that forms a suitable protection against all elements.

It shall be water thinnable. It shall require no primer. On a well-prepared surface, it shall be applied, after one coat of cement primer, in case it is an interior surface and waterproof cement coating in case it is an exterior surface. On a new but highly absorbent surface, a thin coat of the same shall be applied by adding two parts of water by volume to two parts of acrylic emulsion by volume. On previously painted surfaces, one coal of the same shall be applied by thinning four parts of the emulsion with one or two parts of water. It shall be applied by brush, roller or spray. It shall have a covering capacity of 25 - 30 S.Mts./Liter, depending on the surface and shade used. It can be washed to remove the day-to-day dirt, after the surface has been painted, minimum for a month.

**M-57 Barbed Wire:**

The barbed wire shall be of galvanized steel, and it shall generally conform to I.S. 278-1978. The barbed wire shall be of type-I whose nominal diameter for line wire shall be 2.5 mm. and point wire 2.24 mm. The nominal distance between two bars shall be 75 mm. unless otherwise specified in the item. The barbed wire shall be formed by twisting together two-line wires, one containing the barbs. The size of the line and point wires and barb spacing's shall be as specified above. The permissible deviation from the nominal diameter of the line wire and point wire shall not exceed  $\pm 0.08$  mm.

The barbs shall carry four points shall be formed by twisting two-point wires, each two turns, lightly round one line wire, making altogether four complete turns. The barbs shall be so finished that the four points are -set and looked at right angles to each other. The barbs shall have a length of not less than 13 mm. and not more than 18 mm. The point shall be sharp and cut at an angle not greater than 35 degree of the axis of the wire forming the barbs.

The line and point wire shall be circular section free from scale and other defects and shall be uniformly galvanized. The line wire shall be in continuous length and shall not contain any weld other than those in the rod before it is drawn. The distance between two successive splices shall not be less than 15 meters.

The lengths per 100 Kg. of barbed wire I.S. type I shall be as under Nominal 1000 meter Minimum 834 Meter Maximum 1066 Meter.

**M-58 Water Bound Distemper**

It shall be from Asian, Berger or Asian or equivalent as approved by Architect. It shall conform to relevant IS codes.

It can be in powder form or liquid form as per the manufacture's specification. If it is in powder form, it can be prepared by adding warm water in the proportion recommended by the manufacture.

It shall be applied by the conventional distemper brush to all plastered surfaces. It shall be applied by the conventional distemper brush to all plastered walls, ceilings and woodwork. Priming coat shall be applied before applying the paint.

**M-59 Plastic Emulsion Paint**

Plastic emulsion paint shall conform to IS: 5411 of approved brand and manufacture and of the required shade shall be used.

The plastic emulsion paint is not suitable for application on external, wood and iron surface and surfaces which are liable to heavy condensation. These paints are to be used on internal surfaces except wooden and steel.

**M-60 Cement Paint**

The cement paint shall be (conforming to IS: 5410) of approved brand and manufacture.

The cement paint shall be brought to the site of work by the contractor in its original container in sealed condition. The material shall be brought by the contractor at a time in adequate to suffice for the whole work or at least for a fortnight's work. The material shall be kept in joint custody of Architect and engineer-in-charge. Empty tins shall not be removed from the site of work, till this item of work has been completed and passed by the engineer-in-charge.

It shall be manufactured from selected range of raw materials and a special cement, so the it shall be suitable for both indoors and outdoors. It shall be suitably used on concrete renderings, cement/sand renderings, cement/lime/sand renderings, asbestos sheets, fiber boards, brickwork, etc. It shall offer matt finish. It shall require no primer and shall be water thinkable. It shall offer a covering capacity as per manufacture's specification, depending on the surface and shade used. It shall preferably not be applied under direct sunlight to avoid patchy effect.

**M-61 Textured Wall Finish**

It shall be from Bakelite Hilum Ltd or equivalent as approved by Architect or engineer-in-charge. It shall conform to relevant IS codes. It shall be granules, flakes, granite flakes and granules and flakes mix. It shall be of two component, or one component as specified by the Architect or engineer-in-charge. It shall be easily applicable by trained applicators. The single coat shall be 1.5 mm thick as specified in the item description. It shall be weather and fade resistant, water and damp resistant, durable and highly washable. It shall be acid and alkali resistant, high abrasion resistant, non-toxic and shall be capable to taking any shape. It can be applied on wide variety of surface like cement mortar, plywood, plaster board, AC sheet, Asbestos board, gypsum plaster or any other materials, to get homogenous layer.

It shall be water thinkable to avoid water contamination, incombustible and flexible. It shall be good fire-resistant, anti-fungal, good impact resistant having adhesion strength more than 8 kg./cm<sup>2</sup>. There shall not be any development of hair line cracks and no peeling off shall occur, after the maximum drying time of 4 hours and curing period of 2 days.

**M-62 Galvanised iron pipes and fittings**

Galvanised iron pipe shall be of the medium type and of required diameter and shall comply with I.S.I 239-1979. The specified diameter of the pipes shall refer to the inside diameter of the bore. Clamps, screw and all galvanised iron fittings shall be of the standard 'R' or equivalent make.

**M-63 Select Earth**

The selected earth shall be that obtained from excavated material or shall have to brought from outside as indicated in the item. If item does not indicate anything, the selected earth shall have to be brought from outside. The selected earth shall be good yellow soil and shall be got approved from the Engineer-in-charge.

In no case black cotton soil or similar expansive and shrinkable soil shall be used. It shall be clean and free from all rubbish and perishable materials, stones or brick bats. The clods shall be broken to a size of 50. mm or less, Contractor shall make his own arrangement at his own cost for land for borrowing selected earth. The stacking of material shall be done as directed by the Engineer-in-charge in such a way as not to interfere with any constructional activities and in proper stacks. When excavated material is to be used, only selected stuff got approved from the Engineer-in-charge shall be used. It shall be stacked separately and shall comply with all the requirements of selected earth mentioned above

SIGNATURE OF THE CONTRACTOR:  
NAME AND ADDRESS:

EXECUTIVE ENGINEER,  
BHAVNAGAR MUNICIPAL CORPORATION,  
BHAVNAGAR

## 14.0 GENERAL TECHNICAL SPECIFICATION FOR BUILDING WORKS

### GENERAL :

1. In the specification "as directed"/"Approved" shall be taken to mean "as directed"/approved by the Engineer-in-charge.
2. Wherever a reference to any Indian Standard appears in the specifications, it shall be taken to mean as a reference to the latest edition of the same in force on the date of agreement.
3. In "Mode of Measurement" in the specification wherever a dispute arises in the absence of specific mention of a particular point or aspect, the provisions on these particular point or aspects in the relevant Indian Standards shall be referred to.
4. All measurements and computations, unless otherwise specified, shall be carried out nearest to the following limits :
 

(i) Length, width and depth (height)	..... 0.01 Mt.
(ii) Areas	..... 0.01 Sq.Mt.
(iii) Cubic Contents	..... 0.01 Cu.Mt.

In recording dimensions of work.  
The sequence of length, width and height (depth) or thickness shall be followed.
5. The distance which constitutes lead shall be determined along the shortest practical route and not necessarily the route actually taken. The decision of the Engineer-in-charge in this regard shall be taken as final.
6. Where no lead is specified, it shall mean "all leads".
7. Lift shall be measured from Original Ground level.
8. Upto "floor two level" means actual height of floor (Maxi. 4 M.) upto 3 Mt. above plinth level.
9. Definite particulars covered in the items of work, though not mentioned or elucidated in its specifications shall be deemed to be included therein.
10. Reference to specifications of materials as made in the detailed specification the items of works is in the form of a designation containing the number of the specification of the material and prefix 'M' e.g. 'M-5'.
11. Approval of the samples of various materials given by the Engineer-in-charge shall not absolve the contractor from the responsibility of replacing defective material brought on site or materials used in the work found defective at a later date. The contractor shall have no claim to any payment or compensation whatsoever on account of any such materials being rejected by the Engineer-in-charge.
12. The contract rate of the item of work shall be for the work completed in all respects .
13. No collection of materials shall be made before it is got approved from the Engineer-in-charge.
14. Collection of approved materials shall be done at site of work in a systematic manner. Materials shall be stored in such a manner as to prevent damage, deterioration or intrusion of foreign matter and to ensure the preservation of their quality and fitness for the work.
15. Materials, if and when rejected by the Engineer-in-charge, shall be immediately removed from the site of work.
16. No materials shall be stored prior to, during and after execution of a structure in such a way as to cause or lead to damage on overloading of the various components of the structure.
17. All work shall be carried out in a workmanlike manner as per the best techniques for the particular item.
18. All tools, templates, machinery and equipment for correct execution of the work as well as for checking lines, levels, alignment of the works during execution shall be kept in sufficient numbers and in good working condition on the site of the work.
19. The mode procedure and manner of, execution shall be such that it does not cause damage or over-loading of the various components of the structure during execution of after completion of the structure.
20. Special modes of construction not adopted in general Engineering practice, if proposed to be adopted by the Contractor, shall be considered only if the contractor provides satisfactory evidence that such special mode of construction is safe, sound and helps in speedy construction and

completion of work to the required strength and quality. Acceptance of the same by the Engineer-in-charge shall not, however, absolve the contractor of the responsibility of any adverse effects and consequences of adopting the same in the course of execution of completion of the work.

21. All installations pertaining to water supply and fixtures thereof as well as drainage lines and sanitary fittings shall be deemed to be completed only after giving satisfactory tests by the Contractor.
22. The contractor shall be responsible for observing the rules and regulations imposed under the "Minor Minerals Act", and such other laws and rules prescribed by Government from time to time.
23. All necessary safety measures and precautions (including those laid down in the various relevant Indian Standards) shall be taken to ensure the safety of men, materials and machinery on the works as also of the work itself.
24. The testing charges of all materials shall be borne by the Contractor unless recovery at one percent towards using charges is separately made.
  
25. Approval to any or the executed items for the work does not in any way relieve the contractor of his responsibility for the correctness, soundness and strength of the structure as per the drawings and specifications.

SIGNATURE OF THE CONTRACTOR.

EXECUTIVE ENGINEER,  
BHAVNAGAR MUNICIPAL CORPORATION,  
BHAVNAGAR

## 15.0 ITEMWISE DETAILED TECHNICAL SPECIFICATIONS

### SCHEDULE- B

#### CONSTRUCTION OF STORE AREA FOR DRAINAGE DEPARTMENT, BMC AT F.P. NO. 66 UNDER T.P. SCHEME NO. 7 ADHEWADA, BHAVNAGAR

#### Item No. 1:

**Boring holes 3.5 m deep in ordinary soil (for cast in situ piles) and getting out the soil and disposal of the surplus excavated soil as directed within a lead of 50 Meter for following diameter of pipes.(ii) 250 mm.**

#### **Workmanship**

The ground shall be roughly leveled and after make in to the position of piles the holes shall be bored with as spiral angle to the 3.5 M depth and specified diameter using boring guide.

The bore holes shall be truly vertical and uniform bore thought of specified diameter. After boring to the required depth the bore shall be cleared off the soil and disposal of surplus excavated stuff as directed within a lead of 50 M.

#### **Mode of measurement of payments**

The rate for boring holes shall include:

- (a) Roughly leveling the ground in position where piles are to be provided.
- (b) Making the position of piles by pegs and boring guide and also for shifting of boring guide.
- (c) Bailing out water, if any with during boring.
- (d) Disposal of surplus excavated soil within a lead of 50 M. and
- (e) All tools plants, equipment and labour required of satisfactory completion work.

The rate shall be for a unit of one Number

#### Item No. 2:

**Extra for under reaming inside the bore Holes for under reamed piles of following Diameter. (ii) 250 mm**

#### **General**

Any soil which generally yields to the application of pickaxes and shovels or jumpers or scarifies phawaras rakes or any such implement or organic soil, gravel, silt sand turf loam, clay peat etc. fall under this category.

Excavation shall be start after making trial pit aprox.200mt dist. If any damage of service line or any types of other property charges born by the contractor.

#### **Clearing of Sites**

The site on which the pipe is to be laid shall be cleared and all obstructions, like loose, materials and rubbish of all kind, bush, wood and trees shall be removed as directed. The materials so obtained shall be conveyed and stacked as directed with 50 m. lead. The roots of the trees coming in the site shall be cut and coated with a hot asphalt.

The rate of site clearance is deemed to be included in the rate of earth work for which no extra payment will be paid.

Excavation shall be start after making trial pit aprox.200mt dist.

If any damage of service line or any types of other property shall be reinstate/repair by the contractor. All cost of such repair/reinstate shall be born by the contractor.

#### **Setting Out**

All the center line of pipe trenches shall be given by the Engineer-in-charge and it will be the responsibility of the contractor to install substantial reference marks, bench marks etc. and maintain them as long as required true to line, level, curve & slopes. The contractor shall assume full responsibility for



alignment, elevation and dimensions of each and all parts of the work. The labour, materials etc. required for setting out and establishing benchmarks and other reference marks shall be arranged by the contractor at his own cost.

**Excavation**

The excavation for the drain trenches shall include removal of all materials of whatsoever nature and whether wet or dry, necessary for the laying of pipe lines/construction of box drain and sub-structure exactly in accordance with lines, levels, grades and curves shown on the plans L-sections or as directed by the Engineer-in-charge. Trenches shall be excavated to the exact width at of lowest portion of the trench and the sides shall be left vertical as far as possible or according to the angle of repose of various soils. The contractor shall notify the Engineer before starting excavation to enable him to take cross sectional levels for purpose of measurements before the ground is disturbed.

Excavation shall be carried out in strata's specified in item of schedule 'B'. The lift will be also as specified in Schedule 'B'. Excavated material shall be stacked at a minimum distance of 1.5 meters away from the edge of the trench or as directed. Sight rails and boning rods shall be used for checking the gradients of bed or trenches. Before the trench excavation is started, sight rails made of good timber shall be fixed truly vertical at a uniform height, above the invert as per the instruction of the Engineer-in-charge. The center line shall be clearly marked on the sight rails. Depth of excavation shall be checked by bonning rods of suitable size and length as per instructions of the Engineer-in-charge. All the sight rails shall be painted alternatively with two different colors so as to provide better visibility.

The bottom of the trenches shall be leveled both longitudinally and transversely or stepped as directed by the Engineer. The contractor shall, at his own cost, remove such portion of boulders or rock, as required to make the bottom of the trench level. No filling shall be allowed to be the bottom of the trench in level. If by contractor's mistake, Excavation is made deeper than shown on the plan ordered by the Engineer, the extra depth shall be duly watered and rammed as directed by the Engineer as at the cost of the contractor. All rock or other hard foundation shall be cleared off, all soft and loose material cut to a firm surface, either level, stepped as directed by the Engineer. The Engineer may order such changes in the dimensions and elevation of bottom of trenches and may be deemed necessary to secure satisfactory laying of pipelines. The contractor shall at his own expense, make provision for all pumping, dredging bailing out of draining water and the trenches shall be kept free of water, during construction work.

Extra excavation required for collar pit to given dimensions as it is included in the item without any extra cost. After each excavation is completed, the contractor shall notify the Engineer to that effect and no trench will be allowed to be filled up until the Engineer or his authorized agent approved the depths and dimensions of excavation and the nature of the strata met with and the level and/or measurements are recorded.

The work measured shall be maintained till completion and in case of collapse of sides or bottom of trenches due to any reasons, it shall be made good without any extra cost.

**Protection**

In case of excavation is to be done with sloping of stopping sides (i.e. to the given angle) as per the drawing details, then the rates for shoring and strutting shall be considered included in this item. Wherever required the shoring strutting may be done as directed by Engineer-in-charge.

The drainage trenches shall be strongly fenced, and red-light signals shall be kept at night in charge of watchmen to prevent accidents. Sufficient care and protective measure shall be taken to see that the excavation shall not affect or damage the adjoining structure. The contractor shall be entirely responsible for any injury to life and damage to the properties etc. Necessary protection work such as guide ropes, crossing places, barricades, caution Boards etc. shall be provided by the Contractor. The wooden planks for crossing trenches by public as per requirement shall be provided by the contractor without any extra cost.

**Additional Requirements**

At the joints drain the trench shall be excavated to an additional depth of 15 Cms. and width of 30 Cms. and length of 15 Cms. beyond the edge of collar on both the sides or as directed by Engineer-in-charge. The rate includes for such extra excavation made at the joints. The trenches shall be excavated perfectly in straight line. The bottom of trench shall be kept as per invert level or as directed. In obtaining formation on the bottom trench, the usual method of sight rails and bonning rods shall adopted. The contractor shall have to provide and fix and maintain sight rails and bonning rod without any extra cost. If case of emergencies such as unexpected rains, important public occasions, dangers to properties etc. the contractor shall be required to fill up the excavation with necessary consolidation, which may be re excavated for hydraulic test and refilled for which no extra claim for payment shall be entertained. If contractor fails or makes delay to give the hydraulic test of the pipe line laid line any of the section, without any genuine reasons, he shall be responsible to get re excavate any part of the length of trenches refill in such case (i.e. before testing for safety of pedestrian and / or vehicular traffic) as found necessary be the Engineer-in-charge without any extra cost, if found necessary and as directed by the Engineer-in-charge. The contractor shall have to excavate the refilled trenches, during hydraulic test without any extra cost.

In case of excavation across a road, permission of road authorities shall have to be obtained. At all road crossings, trenches shall be excavated only for half width of the road and pipe shall be laid. The other half shall be excavated only after back filling over the laid pipeline making it suitable for the traffic. The contractor shall provide diversion when the pipeline is to be laid along the road as required and shall maintain the diversion or any part of it, of damaged without any extra cost. At all road crossings, the pipe shall be laid below the crust of the road.

The contractor shall break the road surface by Excavation of chiseling to the exact width and length as shown on the drawing or as directed by the Engineer-in-charge. Separate provision made for cutting of road surface and the rate of excavation shall include the breaking of road surface (macadam, tar, road, cement concrete roof, stone paving etc.)

The excavated stuff shall be deposited in uniform layers to avoid mixing with other kind of materials at no objectionable place or as directed by the Engineer-in-charge. The contractor shall have to make his own arrangements for taking trial pits etc. at his own cost, as directed by the Engineer-in-charge.

If necessary, temporary arrangements shall have to be made to divert or convey across all-natural water ways or build up drains etc. Without any extra cost.

All gas/water pipes, cables; any structure shall be protected by the contractor as directed by the Engineer-in-charge, if met during excavation. Any damage caused shall be rectified without any extra cost. It is the responsibility of contractor to get acquainted with various service lines, in case of any damage to such service line, it shall be got repairs by the contractor himself at his cost. The Contractor shall have to pay the bills of reinstatement or compensation or loss of earning on account of such damages to the department/authority concern.

Breaking of brick structures/R.C.C. works, cement concrete etc. coming in excavation shall be considered as excavation in strata shown in the item, as above and will be paid at the same rate.

All safety precautions shall have to be made by the Contractor.

Excavation shall be start after making trial pit aprox.200mt dist.

If any damage of service line or any types of other property charges born by the contractor.

The excavation in narrow streets, lanes shall have to be carried out with full precautions so as that no property may be damaged. Any compensation to be paid to the other party will be paid by the contractor for which the SNAA will not be responsible.

All obstacles, structures etc. shall be removed and made good without further claim or extra cost.

#### **Disposal of Excavated Stuff**

No excavated stuff from foundation trenches of whatever kind they shall be placed even temporarily nearer 1.5-meter distance prescribed by the Engineer from the outer edge of excavation. All

excavated materials will be the property of the GUDA. The rate of excavation includes sorting out of useful materials and stacking them separately as directed within specified lead. The material suitable and useful for backfilling or other use shall be stacked in convenient places but not in such a way as to obstruct free of movement of men, animals and vehicles or encroach upon the area required for constructional purpose. The site shall be kept clean of all debris on completion of the work.

Disposal of excavated materials is subject to the following. Unsuitable obtained from clearing site and excavation shall be disposed off within a lead of 50 meters as directed. Useful materials obtained from cleaning site and excavation shall be stacked within a lead of 50m. beyond the building area as directed. Materials suitable for back filling shall be stacked at convenient places within a lead of 50 m from the structure for reuse. Useful stones from excavation shall be stacked nearly within lead of 50 m. and will allowed to be used by the Contractor on payment at rates laid down in the contract or if not so laid down at scheduled rates of the SNAA or at a mutually agreed rates if there no such rates in the schedule of rates.

#### **Dewatering**

The rate of excavation includes bailing or pumping out all water which may accumulate in the excavation during the progress of the work, either, by percolation, seepage, springs, rain or any other cause and diverting surface flow if any by earthen binds or by any other means. The bunds shall be removed as soon as the work is completed.

The Contractor at his own cost shall have to provide, maintain and operate sufficient number of pumping equipment of approved capacity to keep the area of construction free from water and any sub soil water arising during the construction period.

Pumping shall be so controlled to dispose of water from adequate drainage ditches and shall not be rated so as to make in convenience in constructional operations in general. Precaution shall be taken by the Contractor to prevent any damage to the trench, pipeline of adjustment structure.

The excavation shall be kept free from water by the contractor (1) During excavation (2) When pipe laying and construction of joints are in progress and till the Engineer-in-charge considers that the mortar is sufficiently set. (3) During hydraulic testing inspection and measurements.

#### **Refilling**

The earth to be used for filling shall be free from salts, organic or other foreign matter. All clods of earth shall be broken.

As soon as the work of pipe lying has been completed and measured the site of drain shall be cleared of all debris, brick bats, mortar droppings etc. and filling with earth in layers not exceeding 20 Cms. Each layer shall be adequately watered, rammed and consolidated before the succeeding layer is laid. The earth shall be rammed with iron or wooden rammers where feasible and with the but tends of crow, bars, where rammer cannot be used. When filling reaches finished level, the surface shall be flooded with water for at least 24 hours and allowed to dry and then rammed and consolidated and then rammed and consolidated the finish level of filling shall be kept the shape intended to be given to road surface.

In case where Engineer-in-charge feel necessary the consolidation may be done by power rollers. The extent of consolidation required shall be specified or as directed.

#### **Mode of Measurement and Payment**

The payment of a various classes of excavation, depending upon the depth of excavation, shall be made at the unit rate per cubic meter for the quantity actually excavated and accepted by the Engineer limited to dimensions shown in the sanctioned plans L-Section or as directed by the Engineer. Excavation in excess of the sanctioned dimensions shall not be measured nor paid for and if so, ordered by the Engineer. The contractor shall have to fill up the excess depth with selected excavated stuff duly watered and rammed as directed by the Engineer-in-charge without any extra payment to the Contractor.

Dimension shall be measured correct to two places of decimals of a meter and individual quantity shall be calculated to two places of decimals of a cubic meter.

The maximum permissible width of excavation for the pipe trenches shall not be greater than the internal diameter of the pipe to be laid plus 0.30 meter working space on either side of the pipeline as measured at the top of the trench.

The minimum width of a pipe trench at top shall be 0.60 meter irrespective of the diameter of the pipe below 150 mm.

Wherever extra width of excavation shall be necessary for shoring and strutting, of the trenches, on account of the nature of the soil, such extra width required to accommodate the shoring board shall not be paid separately.

The rate for the item of excavation shall include (Unless and otherwise mentioned).

Clearing of site.

- Setting out work including all materials and labour.
- Dewatering of excavation pit trench during the progress of work
- Dismantling the existing road surfaces of concrete/ asphalt / or any other type of road surface including removing and stacking boulders materials etc.
- Excavation & removal, sorting and stacking of all excavated stuff as directed.
- Refilling the drain trenches with approved materials up to original ground level.
- Necessary protection arrangements including labour, materials equipment etc. it ensure safety and protection against risk or accident.
- Providing facilities for inspection and measurements at any time by the concerned BMC.

Compensation for injury to life and damage to property or to any services if caused during progress of work.

All measurement shall be take true vertical depth from the fixed invert of drain. The depth shall be measured from invert of drain up to G.L. bottom of road leveling. No extra shall be paid for thickness of pipe and collar pits.

The rate shall be paid for a unit of one cum.

#### **Item No.5 & 6:**

**Excavation for pipe line trenches for water supply, sewerage line, manhole etc. all with shoring and strutting if required as per required gradient and line including safety provisions using site rails and stacking excavated stuff including up to all required lead cleaning the site etc. complete for all lifts and strata as specified. etc. Completed as per director.**

**0.00 to 1.50 mt depth**

**b) in hard murrum, boulders incl. macadam road.**

**1.5 to 3.0 mt depth**

**b) in hard murrum, boulders incl. macadam road.**

The depth of Excavation and classification of strata will be as approved by EIC. In no case, width of excavation shall be paid the approved plan of excavation as enclosed along with this tender. It should be the responsibility of the contractor to collect copy of approved plan of excavation before executing the project. Excess excavation than approved excavation plan shall not be measured and paid. However, if required, agency shall have to make excess excavation good by placing lean concrete not less than M-10 grade or as directed by concerned EIC.

#### **Clearing Of Sites**

The rate of site clearance is deemed to be included in the rate of earth work for which no extra payment will be paid.

#### **Setting Out**

All the centre line of pipe trenches shall be given by the Engineer-in-charge and it will be the responsibility of the contractor to install substantial reference marks, bench marks etc. and maintain them as long as

required true to line, level, curve & slopes. The contractor shall assume full responsibility for alignment, elevation and dimensions of each and all parts of the work. The labour, materials etc. required for setting out and establishing bench marks and other reference marks shall be arranged by the contractor at his own cost.

**Excavation**

The excavation for the drain trenches shall include removal of all materials of whatsoever nature and whether wet or dry, necessary for the laying of pipe lines/construction of box drain and sub-structure exactly in accordance with lines, levels, grades and curves shown on the plans L-sections or as directed by the Engineer-in-charge. Trenches shall be excavated to the exact width at of lowest portion of the trench and the sides shall be left vertical as far as possible or according to the angle or repose of various soils. The contractor shall notify the Engineer before starting excavation to enable him to take cross sectional levels for purpose of measurements before the ground is disturbed.

Excavation shall be carried out in strata specified in item of schedule `B'. The lift will be also as specified in Schedule `B'. Excavated material shall be stacked at a minimum distance of 1.5 meters away from the edge of the trench or as directed. Sight rails and boning rods shall be used for checking the gradients of bed or trenches. Before the trench excavation is started, sight rails made of good timber shall fix truly vertical at a uniform height, above the invert as per the instruction of the Engineer-in-charge. The centre line shall be clearly marked on the sight rails. Depth of excavation shall be checked by boning rods of suitable size and length as per instructions of the Engineer-in-charge. All the sight rails shall be painted alternatively with two different colours so as to provide better visibility.

The bottom of the trenches shall be levelled both longitudinally and transversely or stepped as directed by the Engineer. The contractor shall, at his own cost, remove such portion of boulders or rock, as required to make the bottom of the trench level. No filling shall be allowed to being the bottom of the trench in level. If by contractor's mistake, Excavation is made deeper that shown on the plan ordered by the Engineer, the extra depth stuff duly watered and rammed as directed by the Engineer as at the cost of the contractor. All rock or other hard foundation shall be cleared off, all soft and loose material cut to a firm surface, either level, stepped as directed by the Engineer. The Engineer may order such changes in the dimensions and elevation of bottom of trenches and may be deemed necessary to secure satisfactory laying of pipe lines. The contractor shall at his own expense, make provision for all pumping, dredging bailing out of draining water and the trenches shall be kept free of water, during construction work.

Extra excavation required for collar pit to given dimensions as it is included in the item without any extra cost. Agency should have to excavate all pipe line trenches in all strata & depth as mentioned in BOQ.

After each excavation is completed, the contractor shall notify the Engineer to that effect and no trench will be allowed to be filled up until the Engineer or his authorised agent approved the depths and dimensions of excavation and the nature of the strata met with and the level and/or measurements are recorded. The work measured shall be maintained till completion and in case of collapse of sides or bottom of trenches due to any reasons, it shall be made good without any extra cost.

**Protection**

In case of excavation is to be done with sloping of stopping sides (i.e. to the given angle) as per the approved drawing details, then the rates for shoring and strutting shall be considered included in this item. Wherever required the shoring strutting may be done as directed by Engineer-in-charge.

The drainage trenches shall be strongly fenced and red-light signals shall be kept at night in charge of watchmen to prevent accidents. Sufficient care and protective measure shall be taken to see that the excavation shall not affect or damage the adjoining structure. The contractor shall be entirely responsible for any injury to life and damage to the properties etc. Necessary protection works such as guide ropes, crossing places, barricades, caution Boards etc. shall be provided by the Contractor. The wooden planks for crossing trenches by public as per requirement shall be provided by the contractor without any extra cost.

**Additional Requirements**

At the joints the trench shall be excavated to an additional depth of 15 Cms. and width of 30 Cms. and length of 15 Cms. beyond the edge of collar on both the sides or as directed by Engineer-in-charge. The rate includes for such extra excavation made at the joints. The trenches shall be excavated perfectly in straight line. The bottom of trench shall be kept as per invert level or as directed. In obtaining formation on the bottom trench, the usual method of sight rails and boning rods shall be adopted. The contractor shall have to provide and fix and maintain sight rails and boning rod without any extra cost.

If case of emergencies such as unexpected rains, important public occasions, dangers to properties etc. the contractor shall be required to fill up the excavation with necessary consolidation, which may be re excavated for hydraulic test and refilled for which no extra claim for payment shall be entertained.

If contractor fails or makes delay to give the hydraulic test of the pipe line laid line any of the section, without any genuine reasons, he shall be responsible to get re excavate any part of the length of trenches refill in such case (i.e. before testing for safety of pedestrian and / or vehicular traffic) as found necessary be the Engineer-in-charge without any extra cost, if found necessary and as directed by the Engineer-in-charge. The contractor shall have to excavate the refilled trenches, during hydraulic test without any extra cost.

In case of excavation across a road, permission of road authorities shall have to be obtained. At all road crossings, trenches shall be excavated only for half width of the road and pipe shall be laid. The other half shall be excavated only after back filling over the laid pipe line making it suitable for the traffic. The contractor shall provide diversion when the pipe line is to be laid along the road as required and shall maintain the diversion or any part of it, of damaged without any extra cost. At all road crossings, the pipe shall be laid below the crust of the road.

The contractor shall break the road surface by Excavation of chiselling to the exact width and length as shown on the drawing or as directed by the Engineer-in-charge. Separate provision made for cutting of road surface and the rate of excavation shall include the breaking of road surface (macadam's, tar, road, cement concrete roof, stone paving etc.)

The excavated stuff shall be deposited in uniform layers to avoid mixing with other kind of materials at no objectionable place or as directed by the Engineer-in-charge.

The contractor shall have to make his own arrangements for taking trial pits etc. at his own cost, as directed by the Engineer-in-charge.

If necessary, temporary arrangements shall have to be made to divert or convey across all natural water ways or build up drains etc. without any extra cost.

All gas/water pipes, cables; any structure shall be protected by the contractor as directed by the Engineer-in-charge, if met during excavation. Any damage caused shall be rectified without any extra cost. It is the responsibility of contractor to get acquainted with various service lines, In case of any damage to such service line, it shall be get repairs by the contractor himself at his cost. The Contractor shall have to pay the bills of reinstatement or compensation or loss of earning on account of such damages to the department/authority concern.

Breaking of brick structures/R.C.C. works, cement concrete etc. coming in excavation shall be considered as excavation in strata shown in the item, as above and will be paid at the same rate.

All safety precautions shall have to be made by the Contractor.

The excavation in narrow streets, lanes shall have to be carried out with full precautions so as that no property may be damaged. Any compensation to be paid to the other party will be paid by the contractor for which the UT of D D & DNH will not be responsible.

All obstacles, structures etc. shall be removed and made good without further claim or extra cost.

#### **Disposal of Excavated Stuff**

No excavated stuff from foundation trenches of whatever kind they shall be placed even temporarily nearer 1.5-meter distance prescribed by the Engineer from the outer edge of excavation. All excavated materials will be the property of the client. The rate of excavation includes sorting out of useful materials and stacking

them separately as directed within specified lead. The material suitable and useful for backfilling or other use shall be stacked in convenient places but not in such a way as to obstruct free of movement of men, animals and vehicles of encroach upon the area required for constructional purpose. The site shall be kept clean of all debris on completion of the work.

**Disposal**

Disposal of excavated materials is subject to the following. Unsuitable excavated stuff obtained from clearing site and excavation shall be disposed of within a lead of BOQ item meters as directed. Useful materials obtained from cleaning site and excavation shall be stacked within a lead of 50m if sufficient storage area is available for stacking. As most of the lanes of Diu are narrow, it may happen that part or whole of the excavated stuff is required to be transported to storage area much beyond the BOQ limit of 50M during excavation and brought back after pipes are laid. Necessary bulkage allowance shall be allowed in excavated quantity. Efforts shall be made to stack the materials suitable for back filling at convenient places within a lead of 50 m from the structure for reuse. Boulders and stones obtained from excavation up to 150 mm size shall be allowed to be used by the Contractor during refilling provided pipes are protected by layers of soft earth first surrounding pipes and no pipe is in direct contact with such large size stone.

**Dewatering**

The rate of excavation includes bailing or pumping out all water which may accumulate in the excavation during the progress of the work, either, by percolation, seepage, springs, rain or any other cause and diverting surface flow if any by earthen binds or by any other means. All such accumulation of water in the trench which can be removed without use of mechanical equipment is already included under item of excavation and will not be paid separately. Only those excavation where mechanical pumps are deployed qualifies to get compensation. The bunds shall be removed as soon as the work is completed.

The Contractor at his own cost shall have to provide, maintain and operate sufficient number of pumping equipment of approved capacity to keep the area of construction free from water and any sub soil water arising during the construction period. However, payment for dewatering shall be made only on Cum of excavation made including dewatering.

Pumping shall be so controlled to dispose of water from adequate drainage ditches and shall not be rated so as to make in convenience in constructional operations in general. Precaution shall be taken by the Contractor to prevent any damage to the trench, pipe line of adjustment structure.

The excavation shall be kept free from water by the contractor (1) During excavation (2) When pipe laying and construction of joints are in progress and till the Engineer-in-charge considers that the mortar is sufficiently set. (3) During hydraulic testing inspection and measurements.

**Refilling**

The earth to be used for filling shall be free from salts, organic or other foreign matter. All clods of earth shall be broken.

As soon as the work of pipe lying has been completed and measured the site of drain shall be cleared of all debris, brick bats, mortar droppings etc. and filling with earth in layers not exceeding 20 Cms. Each layer shall be adequately watered, rammed and consolidated before the succeeding layer is laid. The earth shall be rammed with iron or wooden rammers where feasible and with the battens of crow, bars, where rammer cannot be used. When filling reaches finished level, the surface shall be flooded with water for at least 24 hours and allowed to dry and then rammed and consolidated and then rammed and consolidated the finish level of filling shall be kept the shape intended to be given to road surface.

In case where Engineer-in-charge feels necessary the consolidation may be done by power rollers. The extent of consolidation required shall be specified or as directed.

**Excavation In Soft Rock Not Requiring Blasting (In Soft Rock And Masonry In Cm Or Lm Or Lime Concrete)**

The excavation in soft or disintegrated rock shall be carried out by crow bars, pickaxes or pneumatic drills or any other suitable means If contractor desires to resort to blasting, he can do so with permission of the

Engineer-in-charge but nothing extra shall be paid to him. The materials available from soft excavation shall be properly stacked within 50 M. lead and 1 5 m. lift and shall be the property of department. The classification of strata of the foundation soil shall be done by the Engineer-in-charge and shall be acceptable to the contractor.

**HARD ROCK, CC 1:2:4 AND RCC WITH BLASTING, BREAKING, CHISELING ETC.**

However, this shall include the type of rock and boulder which may quarried or split with crow bars. Laterite and conglomerate also come under this category.

Excavation shall be done by blasting to the dimensions shown in the drawings or as directed. The blasting shall be carried out only with written permission of the Engineer-in-charge. All the laws, regulations etc, - pertaining to the precautions, acquisition, transport, landing and use of explosive shall be rigidly followed. The Magazine for the storage for the explosive shall be built to the design and specifications of explosive authority and located at the approved site No unauthorised persons shall be admitted into the magazine and when not in use it shall be kept securely locked No matches or inflammable materials shall be allowed in Magazine. The Magazine shall have an effective lightning conductor. The rules of explosive 1940 revised from time 10 time shall be followed strictly for obtaining starting, handling, undertaking blasting work.

The contractor shall be responsible for damage to property, workmen public due to any accident due to use of explosives and operations.

**Precautions for Blasting**

1. The blasting operation shall remain in charge of competent and experienced supervisor and workmen who are thoroughly acquainted with the detail of handling explosive and blasting operations. The blasting shall be carried out during fixed hours of the day, preferably during the mid-day lunch hours or at the close of the work as ordered in writing by the Engineer-in-charge. The hours of blasting shall be notified in advance to the people in the vicinity. All the charges shall be prepared by the man in charge only.
2. Red danger flags shall be displayed prominently in all direction during the blasting operations.
3. People except those who actually light the fuse shall be prohibited from entering into this area. The flags shall be stationed at 200 m. from the firing-site in all directions and all persons including workmen shall be excluded from the flagged area at least 1.0 minutes before the firing warning whistle being sounded for this purpose
4. During excavation in rock by blasting, the lowest 15 cm. of stratus shall be blasted with light charge so as not to shatter or weaken the underlying rock on which the foundation will be actually laid If excavation in rock is done to large widths and length than those shown on the drawings or as directed, no payment shall be made for such over break. If excavation is done to depths greater than shown on the drawings or directed, excess depth shall be made up with foundation grade concrete as directed at the contractor's cost.
5. The charged hole shall be drilled to the required depth and in suitable places when blasting is done with powder, the fuse cut to the required length shall be inserted in the holes and the powder dropped in. The powder shall be gently tamped with copper rod with rounded ends. The explosive powder shall then be covered with trapping materials which shall be tamped lightly out firmly. When blasting is done with dynamite and other high explosive, dynamite cartridges shall be prepared by inserting the square cut ends of fuse into the detonator, and finished with dippers at the open ends The detonator should be gently pushed into the detonator and finished with dippers at the opened ends. The detonator should be gently pushed explosive. Bore holes shall be of such size that the cartridges can be easily passed down. The holes shall be cleared of all debris and explosive inserted The space for about 20 cms, above the charge shall then be gently filled with dry clay pressed home and rest of tamping is with firmed any convenient materials gently packed with a wooden cover.
6. At a time not more than 10 such charge shall be prepared and fired. The man in charge shall blow a whistle in a recognised manner for cautioning the people. All the people shall then be required to move to



number of explosions. He shall satisfy himself that all the charges have been exploded before allowing the workmen to go to the work site.

7. The contractor shall be fully responsible to strictly follow the prevailing rules and procedures regarding blasting procedures

Misfire

1. In case of a misfire the following procedure shall be observed:

2. Sufficient time shall be allowed to account for the delayed blast. The man in charge shall inspect all the charges and determine the missed charge.

3. If it is the blasting powder charge it shall be completely flooded with water. A new hole shall be drilled at, about 45 cm. from the old and fired. This should blast the old charge Should<sup>^</sup> it not blasts the old charge; the procedure shall be repeated till the old charge is blasted.

4. In case of charge of gelatines, dynamite etc, the man in charge shall gently remove the tamping and the primer with detonator and primer shall then be used to blast the charge. Alternatively, the hole may be cleared of one foot of tamping and the direction then ascertained by placing a stick in the hole Another hole may then be drilled 15 cm away and parallel to it. The man in charge shall report to the office all cases of misfire and cause of the same and what steps were taken in connection therewith.

5. If a misfire has been found to be due to defective or dynamite, the whole quantity in the box from which defective article was taken must be sent to authority as directed for inspection to ascertain whether all the remaining materials in the box are also defective or not.

**Accidents:**

1. The contractor shall be solely responsible for any accident during the entire procedure of handling explosive and blasting and shall pay necessary compensation to persons affected or damage to lands or property etc, due to the blasting, without extra claims on the department.

Account of explosives:

1. A careful and day to day account of explosives shall be maintained by the contractor in an approved manner and shall be open to inspection of the Engineer-in charge Surprise visits may also be paid by the Engineer-in-charge to the storage and in case of any unaccountable shortage or unsatisfactory accounting, the contractor shall be liable to be penalised by forfeiture of part or whole of his Security Deposit or by cancellation of tender in which case he shall not be entitled for any compensation .

**Mode of Measurement and Payment:**

The payment of a various classes of excavation, depending upon the depth of excavation, shall be made at the unit rate per cubic meter for the quantity actually excavated and accepted by the Engineer limited to dimensions shown in the sanctioned plans L-Section or as directed by the Engineer. Excavation in excess of the sanctioned dimensions shall not be measured nor paid for and if so ordered by the Engineer. The contractor shall have to fill up the excess depth with selected excavated stuff duly watered and rammed with concrete of grade M-10 or higher grade as directed by the Engineer-in-charge without any extra payment to the Contractor.

Dimension shall be measured correct to two places of decimals of a meter and individual quantity shall be calculated to two places of decimals of a cubic meter.

The maximum permissible width of excavation for the pipe trenches shall not be greater than the internal diameter of the pipe to be laid plus 0.30 meter working space on either side of the pipe line as measured at the top of the trench or as laid down in excavation plan. It is responsibility of the contractor to seek copy of approved excavation plan before excavating.

The minimum width of a pipe trench at top shall be 0.60 meter irrespective of the diameter of the pipe below 150 mm.

Wherever extra width of excavation is necessary for shoring and strutting of the trenches on account of the nature of the soil, such extra width required to accommodate the shoring board shall be paid separately subject to condition that written approval of EIC is taken before laying of pipes.

The rate for the item of excavation shall include (Unless and otherwise mentioned).

- General clearing of site.
- Setting out work including all materials and labour.
- Dewatering of excavation pit trench during the progress of work by manual means
- Dismantling the existing road surfaces of concrete/ asphalt / or any other type of road surface including removing and stacking boulders materials etc.
- Excavation in all sort of soil e.g., – hard murrum, boulders, soft rock, hard rock / masonry, road etc.& removal, sorting and stacking of all excavated stuff as directed without any extra cost.
- Refilling the drain trenches with approved materials up to original ground level.
- Necessary protection arrangements including labour, materials equipment etc. it ensures safety and protection against risk or accident.
- Providing facilities for inspection and measurements at any time by the concerned District Panchayat Officials.
- Compensation for injury to life and damage to property or to any services if caused during progress of work.

All measurement shall be taken true vertical depth from the fixed invert of pipe. The depth shall be measured from invert of pipe up to G.L. bottom of road levelling. No extra shall be paid for thickness of pipe and collar pits.

Rate shall be for a unit of one Cubic Meter.

**Item No.7:**

**Dewatering In all sorts of soil and soft murrum, hard Murrum and boulders, Soft Rock, Hard Rock, beyond 1.5 mt. depth from G. L.**

**1.5 to 3.0 mt depth**

**Materials & Workmanship**

The relevant specification of excavation shall be followed including work to be carried out up to 6.0 mt depth or more. The dewatering shall be continuously carried out during excavation to avoid any interruption in carrying out excavation work. Agency will have to arrange for required pumping machinery suitable on the site of various capacities as per requirement to pump available quantity without loss of time.

**Scope**

This specification covers the general requirements of dewatering excavations in general.

**General**

All excavations shall be kept free of water. Grading in the vicinity of excavations shall be controlled to prevent surface water running into excavated areas. Contractor shall remove by pumping or other means approved by Engineer any water inclusive of rain water and subsoil water accumulated in excavation and keep all excavations dewatered until the foundation work is completed and backfilled. Sumps made for dewatering must be kept clear of the excavations required for further work. Method of pumping shall be approved by Engineer but any case; the pumping arrangement shall be such that there shall be no movement of subsoil or blowing in due to differential head of water during pumping. Pumping arrangement shall be adequate to ensure no delays in construction. It is to be noted that District Panchayat will not provide any electricity or any facility to run these pump set/s. It is contractor responsibility to run these pump set/s at its own cost.

When there is a continuous inflow of water and quantum of water to be handled is more that can be handled manually in the opinion of engineer in charge, mechanised pumps or well point system-single stage or multistage, shall be adopted for dewatering. Contractor shall submit to engineer his scheme of pump deployment or well point system including the stage, the spacing, number and diameter of well points,

heads etc. and the number, capacity and location of pumps of approval of EIC. Unless separately provided for in the schedule of prices and written approval of EIC is sought before deployment of pumping machinery, the cost of dewatering shall be deemed to have been included in the item rate for excavation.

#### **Mode of measurements & payment**

Extra payment against dewatering shall be made based on excavation in wet soil condition subject to conditions mentioned above.

The rate shall be for unit of cubic meter. For all lifts specified under the item.

#### **Item No.8:**

**Providing bedding incl. ramming, watering, levelling, consolidating etc. Complete as per standard and instruction of engineer incharge. As above with required quality Sand brought from outside including all lead**

#### **Scope:**

The filling around the pipe immediately after the pipes have been laid and the jointing material has hardened. The sand shall be cleaned, free from boulders, large roots excessive amount of sods or other vegetable matter, and lumps and shall be approved by the engineer. Backfilling up to 300mm above the top of pipe shall be carefully done and the sand thoroughly rammed, tamped or vibrated in layer not exceeding 150mm, particular care being taken to thoroughly consolidate the materials under the haunches of the pipe. Approved pneumatic or light mechanical tamping equipment can be used.

Sand shall be natural sand, clean well graded, hard strong, durable, and gritty particles free from injurious amounts of dust, clay, kankar nodules, soft or flaky particles shale, alkali, salts organic matter, loam. Mica or other deleterious substance and shall be got approved from the Engineer-in-charge. The sand shall not contain more than 5 per cent of silt as determined by field test. If necessary, the sand shall be washed to make it clean.

The fineness modulus of coarse sand shall be less than 2.5 and shall not exceed 3.0. The sieve analysis of coarse shall be as under.

I.S Sieve Weight Designation	Percentage by weight Passing sieve	I.S Sieve Designation	Percentage by Passing sieve
4.75 mm	100	600 Micron	30-100
2.36 mm	90 to 100	300 Micron	5-70
1.18 mm	70 to 100	150 Micron	0-50

#### **Fine Sand**

The fineness modulus shall not exceed 1.0. The sieve analysis of fine sand shall be as under.

I.S Sieve weight Designation	Percentage by Weight Passing sieve	I.S Sieve Designation	Percentage by Passing sieve
4.75 mm	100	600 Micron	40-85
2.36 mm	100	300 Micron	5-50
1.18 mm	75 to 100	150 Micron	0-10

#### **Measurements for Payment**

The Sand filling shall be measured in **cubic meter** for the complete item of work.

#### **Item No.9:**

**Earthwork for embankment including breaking clods, dressing with all lead and lift and including watering rolling and consolidation of subgrade in layers at O.M.C. to required dry density including filling**

**the depression which occur during the process using power roller 8T to 10T.(E) From Borrow area within 3.0KM. lead**

The item shall cover the general requirement of earth work; Borrow Areas with good earth suitable for embankment brought from outside for constructing the earthen working platform at the site of intake well as shown in the drawing and as directed by Engineer in charge of work. This specification covers the general requirement of earthwork for site grading, filling for construction of earthen bund, widening and strengthening of earthen bunds of existing bunds & ancillary intake well works and all other operations covered within the intent and purpose of this specification and are at variance with the corresponding requirements.

**General**

Contractor shall furnish all tools, plants, instruments, qualified supervisory personnel, labour, materials, any temporary works, consumables, any and everything necessary whether or not such items are specifically stated herein for completion of the job in accordance with specification, requirements, etc. The agency shall provide gunny bags at core portion of filling to prevent incoming outside water and dewater it if coming in to working portion of intake well.

Throughout the execution of this work the contractor shall at his own cost establish, construct, protect and maintain all bench marks and reference points to the satisfaction of District Panchayat's engineers & provide all the necessary assistance in taking & recording the measurements by the District Panchayat's engineers. The contractor shall provide necessary leveling & other equipment, printed books for taking the initial and final levels jointly, for establishing benchmarks and lines invariably.

Contractor shall carry out the necessary precise survey before commencing / after completion of the said works by taking accurate levels along the proposed route at 5m intervals or nearer as determined by Engineer based on the ground profile. Initially before starting the work, the contractor will carry out the contour layout of the full area by taking vertical & horizontal coordinates with the help of precise equipment like total station and contour intervals marked or as directed by Engineer in charge, at 0.5M and spot levels will be on grid of 5M x 5M both ways. Contractor shall also carry out the survey during the progress of the work assessment of the progress made as well as for progressive payments jointly with District Panchayat's Engineers as directed by the Engineer in charge from time to time. These levels and survey shall be checked by District Panchayat's Engineers and thereafter properly recorded. The cost of such survey is deemed to be included in Contractor's quoted rates.

Such checking by the District Panchayat's site engineers or any agency appointed as Project Management Consultant on behalf of DISTRICT PANCHAYAT shall not relieve the contractor from his responsibility of maintaining the accuracy of work. Any discrepancy or error detected during the course of execution of the work and/or at the end of the work, the contractor shall be responsible to set right the errors as per the instructions of the District Panchayat's site engineers without any extra cost.

**Preparation of Embankment Areas (Site Clearance)**

All areas required for embankment shall be cleared of all trees and stumps, roots, bush rubbish and other objectionable material. Particular care shall be taken to exclude all organic matter from the material to be placed in the bund embankment. All cleared materials shall be disposed off as directed. The cleared areas shall be maintained free of vegetation growth during the progress of the work.

The area to be filled shall be cleared of fences, trees with roots & plants of any diameter, logs, stumps, bush vegetation, rubbish etc. and other objectionable matter. Where earth fill is intended, the area shall be stripped of all loose / soft patches, top soil containing objectionable matter / material / before fill commences. The cost of such site clearing is deemed to have been including in Contractor's quoted rates. The cut trees and removed roots shall be the property of the DISTRICT PANCHAYAT and usable materials shall be credited to the DISTRICT PANCHAYAT as per directive of Engineer in charge.

To avoid the entry of water of running nalas / entry of rain/ monsoon water into the construction site where digging is to be carried out, the contractor shall maintain earthen bund which will be constructed by him,

for which no extra payment will be made or shall make preventive measures to avoid entry of such water at his own cost.

In case the contractor desires to form a ramp on either side of embankment to facilitate for transporting of materials, then the contractor shall do so with permissions of Engineer in charge. No separate payment shall be made for such ramps and has to remove the same if required. The item also includes preparation & maintenance of haul/approach roads in the borrow pit as well as up to dumping place throughout the contract period & no separate payment shall be made for the same.

The contractor shall have to survey, layout and establish baselines, benchmarks and grades etc. and provide all necessary labours, materials, tools and tackles etc. and all co-operation to the District Panchayat's site Engineer, for which the contractor shall not claim any extra payment to check the alignment, grade, levels, whenever & every time they are asked for all work areas at his cost. Payment shall be made for filling only based on volume calculations by prismoid AI formula considering depth as the difference in levels between the bottom of the actual excavated area and existing ground levels and for that joint levels will be taken in grid of 5.0 M x 5.00 M or nearer as directed by Engineer in charge, before starting the filling and after carrying out the filling at required elevation.

The contractor shall protect during construction of the embankment and in the event of its being washed away by rain or damaged in any other way, the contractor shall at his own cost restore any part & make it good to the satisfaction of the DISTRICT PANCHAYAT.

Necessary key, rubble pitching, drain etc., as shown in the drawing or as directed by Engineer in charge of work shall be provided as per site condition and shall have to be carried out in this item, before starting the filling for earthen embankment. The surplus earth will have to be spread, to make up the adjacent ground (if necessary) or otherwise shall be removed from the site and disposed off, as directed by the Engineer in charge within a lead of 500 M. No separate payment shall be made for this.

Material required for the embankment shall be brought from approved borrow areas. The depths of cut in all parts of the borrow areas will be determined by the Engineer depending on the site condition and the cuts shall be made to such depths only. The excavation of materials from borrow areas shall be done with Poclain/ Hitachi or by any approved mechanical means.

Borrow area shall not be opened within a distance of ten times the height of embankment continuous to the heel or the toe of the embankment or 30 meters, whichever is more. Borrow area shall be operated so as not to impair the usefulness or mar the appearance of any part of the work or any other property. The excavation surfaces and surface of waste materials shall be left in a reasonable smooth and even condition.

#### **Stripping of Embankment Area**

Embankment areas shall be removed of top material, sodic or organic matter and any black cotton soil that is unsuitable for the embankment. The borrow area is to be excavated for stripping shall be disposed off at the place and in manner at the discretion of the Engineer in charge and as directed by him. The minimum depth of stripping shall be 500 MM and will be paid under item of excavation.

#### **Borrow area watering / dewatering**

The natural moisture content of material in the borrow area as well as the optimum moisture content corresponding to the maximum dry density (Standard Proctor) for the material in the particular borrow area shall be obtained from laboratory tests. Additional moisture if required shall be introduced into the borrow area by watering well in advance of excavation, to ensure uniformity of moisture content. If in any borrow area before or during excavation there is excess moisture, steps shall be taken to reduce the moisture by the selective excavation to secure the materials of required moisture by excavating drainage ditches, by allowing adequate time for drying or by other means. To avoid formation of pools in the borrow areas during excavation operations, drainage ditches from borrow areas to the nearest outlet shall be excavated.

#### **Fill Materials and Method of filling**

##### **Earth Fill**

The Earth fill material for embankment shall be mainly available selected excavated material from the bund borrow pit area.

All fill material will be subject to Engineer's approval. If any material is rejected by Engineer, contractor shall remove the same forth with from the site as directed by the Engineer.

The Contractor shall conduct at his cost such tests as the Engineer may consider necessary both initially and during the progress of work to ensure the suitability of the material for use on the works. The tests involved in general are mechanical analysis, consistency limits, soil classifications, proctor density and test for optimum moisture content. Such suitability test shall be carried out by the Contractor at his own cost on the samples from the excavated borrow area / bund area. For all fill materials, the contractor shall determine optimum moisture content to achieve maximum compaction by conducting suitable laboratory tests on samples of all material used for filling. The cost of all samples, tests etc. that the Engineer may consider necessary is deemed to be included in contractors quoted rates.

The fill materials shall be transported from the bund excavation borrow pit areas directly to the bund bund area by using dumpers, truck or any other approved mechanical means.

#### **Embankment**

The embankment shall be constructed to the lines and grades shown on the drawings. Placement of fill shall be done in an orderly way and in an efficient and workman like manner, so as to produce fills having such density, strength and permeability as will ensure the highest practicable degree of stability and performance of the embankment.

For the portion of filling to strengthen the bund of the existing bund, necessary compaction shall have to be carried out to the satisfaction of the Engineer in charge at no extra cost. However, when an existing embankment is to be widened, continuous horizontal benches each at least 0.5 M wide shall be cut into the existing slope for ensuring adequate bond with the fresh embankment material to be added. The material obtained from the cutting of benches, if of good quality, can be utilized in widening of the embankment. No extra payment shall be made for such cuttings etc.

No bushes, roots, sods or other perishable or unsuitable materials, organic materials etc. shall be placed in the embankment. The suitability of each part of the foundation for placing embankment materials thereon and of all materials for use in embankment construction shall be determined by the Engineer. The bund may be constructed in separate portions or reaches provided that:

The slopes of the bonding surfaces between the previously completed portion of the embankment and materials to be placed in each zone shall not be steeper than 4 horizontal to 1 vertical (in longitudinal direction), and the embankment is constructed right across the whole section in each portion or reach.

#### **Placing the fill material**

Before placing the fill, the foundation shall be prepared / compacted as per closed "Stripping of Embankment Area". Prior to placing the first layer of embankment on the foundation, moistening the surface shall be done. The distribution and gradation of materials throughout the fill shall be as shown in the drawings or as directed. The fills shall be free from lenses, pockets, streaks or layers of material differing substantially in texture or gradation from the surrounding material. The combined excavation and placing operations shall be such that the materials when compacted in the fill will be blended sufficiently to produce the best practicable degree of compaction and stability.

No stones, cobbles or rock fragments, having maximum dimensions more than 100 mm shall be placed in the fill. Such stones and cobbles shall be removed either at the borrow pit or after being transported to the fill but before the materials in the fill are rolled and compacted. Such stones or cobbles shall be placed in other portions of embankment, if found suitable or rejected as directed.

The materials shall be placed in the fill using dozers in continuous horizontal layers stretching right across the whole section not more than 300 mm in compacted thickness and rolled as herein specified.

#### **Formation of Extra width for adequate compaction**

In order to ensure adequate compaction, the earth layers shall be constructed to a minimum extra width of 0.5 m on both sides, then the design profile indicated in the construction drawing. This extra width shall be trimmed / dressed to the design profile indicated in the construction drawing, at no extra cost.

During construction a small transverse slope from center towards the edges should be given to avoid pools of water forming due to rains. Before placing the subsequent layer, the surface of previous layer shall be moistened and/or worked with harrow, scarifiers or other suitable equipment in an approved manner to a sufficient depth to provide a satisfactory bonding between two successive layers. If the rolled surface of any fill is found to be too wet for proper compaction, it shall be raked up, allowed to dry or shall be worked with a harrow or any other approved equipment to reduce the moisture content to the required amount and then it shall be re-compacted before the next layer is placed. Before compacting earth layers, the placed material shall be mixed thoroughly using a tiller to ensure uniform moisture content. Earth surfaces are likely to become dry in short intervals and hence enough moisture shall be added between different passes to ensure proper compaction.

When placing the soils against steep rock abutment or walls or masonry or concrete structure, the construction surface of embankment shall be sloped away from rock or masonry or concrete structure for a distance of 3 m to 4m at an inclination not steeper than 6 horizontals to 1 vertical. If the foundation surface is too irregular to allow the use of a large roller directly against a structure or rock out crop, the roller shall be used to compact the soil as close to the structure or the out crop as possible and the portion of the embankment directly against the rock / structure shall be compacted with pneumatic hand tampers in thin layers. The moisture content of the earth placed against the rock / structure shall be high enough to allow it to be compacted into all irregularities of the rock / structure. Care shall be taken in placing the first layer of the fill so that no damage is caused by the hauling machinery to the base grade as this may get concealed by the spread layer or fill. Heavy rollers shall not be employed for compacting the fill over masonry / concrete structure till the thickness of the layers already compacted by other means is at least 500 mm thick. The soil for the first layer shall be at moisture content sufficient to enable bonding of the fill with the rock surface.

#### **Weather Conditions**

Embankment materials shall be placed only when the weather conditions are satisfactory to permit accurate control of the moisture content in the embankment materials. No fill material shall be placed when it is raining.

#### **Moisture Control**

Prior to and during compacting operations, the material in each layer of earth shall have moisture content about 2% less than the optimum moisture content unless the field trials have demonstrated a different practical value. Laboratory investigations may impose some restrictions on the lower limits of the practicable moisture contents on the basis of studies of compaction in embankment. As far as practicable the materials shall be brought to the proper moisture content in the borrow area before excavation. If additional moisture content is required, it shall be added on the embankment by sprinkling water before rolling the layer. The contractor shall make his own arrangements for distribution of water from District Panchayat's supply. If the moisture content is greater than required, the material shall be spread and allowed to dry before starting rolling. The moisture content shall be uniform throughout the layer of material and ploughing, discing, harrowing or other methods of mixing may be required to obtain uniform distribution. If the moisture content is more than or less than the range of the required practicable moisture content, or if it is not uniformly distributed throughout the layer, rolling shall be stopped and shall be started again only when the above conditions are satisfied. In no case the moisture content shall be more than Optimum Moisture Content.

#### **Compaction Equipment**

##### **Pneumatic Rollers**

Pneumatic rollers shall have four wheels equipped with pneumatic tyres, and a body suitable for ballast loading so that the load per wheel may be varied as necessary from 7000 kgs to 11000 kgs. Tyre pressure shall not exceed 2.5 kgs / sq. cm as greater pressure tends to cut earth surface. The tyres shall be of such size and ply as can be maintained during rolling operations; a tyre pressure not greater than 2.5 kgs / sq. cm for a 11000 kgs wheel load. The roller wheels shall be located abreast and each wheel and tyre shall be mounted in such a way that all wheels exert approximately equal loads, when traversing uneven grounds. The spacing of the wheels shall be such that the distances between the nearest edges of adjacent tyres at the imprint will not be greater than 50 percent of the width is attached to a tractor, the entire tractor and roller unit shall be capable of executing a 180° turn on a 5-metre radius.

**Vibratory Rollers**

Vibratory rollers shall have static linear load 20 to 35 kg / cm<sup>2</sup> (dead weight 10 to 20 tones) and the vibrators shall have frequency between 1100 and 1800 pulses per minute and amplitude of vibration shall be 1.6mm.

**Rolling and Tamping****Test Section**

Before starting actual rolling / compaction of the fill material in the embankment proper, the contractor shall form a test section, using the fill material from the same borrow area, as for the embankment of at least 25m width and about 1 meter height to establish the number of passes required, to achieve a dry density equal to 95% of maximum dry density (Standard Proctor)

The test results shall be submitted to the engineer for his approval.

Actual compaction of the fill material shall start after the satisfactory performance of the compaction equipment has been established and the test report as mentioned above has been approved by the Engineer.

**Rolling**

When each layer of material has been conditioned so as to have the proper moisture content uniformly distributed throughout the material, it shall be compacted by passing the roller. The exact number of passes shall be decided after necessary field tests. The layers shall be compacted in strips overlapping not less than 0.6m. The rollers or loaded vehicles shall travel in a direction parallel to the axis of the bund. Turns shall be made carefully to ensure uniform compaction. Rollers shall always be pulled. Density tests shall be made after rolling each layer and the dry density attained shall be not less than 95% of maximum dry density (Standard Proctor) obtained in the Laboratory for the type of material used. Wherever the test results indicated that the desired compaction has not been achieved, the layers shall be further compacted until the specified compaction has been achieved. Approval from District Panchayat's site engineer shall be obtained before placing the new layer.

The earth fill shall commence on dry portions of existing bund. In no case, the earth fill shall commence on swampy region. Dry working area shall be formed & maintained by the contractor at his cost and no extra payment shall be made in this regard.

Surplus fill material, if any, after the completion of work shall be deposited or disposed off as directed by the District Panchayat's Site Engineers without any extra payment.

**Tamping**

Rollers will not be permitted to operate within 1.0 meter of concrete and masonry structures. In locations where compaction of the earth fill material by means of the roller is impracticable or undesirable, the earth shall be specially compacted as specified herein at following locations:

- a) Portions of the earth fill in bund adjacent to masonry / concrete structures.
- b) Earth fills in bund adjacent to steep abutments.
- c) Earth fill in bund around concrete/HDPE drain pipes embedded in floor/embankment in the vicinity of 0.6 m and
- d) Earth fills at locations specially designated by the Engineer.



Fill shall be spread in layers not more than 100 mm in compacted thickness and shall be moistened to have the required moisture content. When each layer of material has been conditioned to have the required moisture content, it shall be compacted to achieve the dry density of not less than 95% of maximum dry density (Standard Proctor) by hand held vibratory tampers and all equipment and methods used shall be subject to approval based on evidence of actual performance. The moisture control and compaction shall be equivalent to that obtained in the earth actually placed in the bund embankment in accordance with clause "Moisture Control" and "Rolling and Tamping".

#### **Inspection and Tests**

Control tests shall be carried out in established laboratory from time to time to determine whether the earth layers produced by methods employed satisfies the requirements of the specifications. Routine field tests shall also be carried out by the Engineer and the work shall be inspected regularly. Field density tests either by core cutter method or sand replacement method shall be carried out. Field density test should be particularly and specially made in the following areas:

At least one:

- I. Where the degree of compaction is doubtful.
- II. Where embankment operations are concentrated i.e. where 2 or more layers are placed one over the other on the same day.
- III. To represent every 500 Cmt. of earth placed in the embankment.
- IV. At least one test for every full or part shift of compaction operations.
- V. At least one test for every 50 m length of bund in each layer.

Test for every 500 sq. meters area of the trimmed slopes.

The Engineer shall determine whether the desired results are being obtained.

The Contractor shall provide all facilities such as labour, conveyance, equipment (other than those actually required for testing) to enable the owner and all such tests are to be carried out by the contractor, at his own risk and cost. No extra payment shall be made.

The contractor shall get test of compaction done in Govt. or Semi Govt. approved laboratory at least one test for 0.2 mt compacted layer of every full length of embankment.

#### **Dressing and Trimming of the Slopes**

The construction of earthen embankments/ bunds shall have 0.50 m extra width than the design and drawing after compaction. The both side slopes of the embankment shall be neatly dressed on both sides to the design profile as indicated in the construction drawing after the complete height of bund is constructed in a particular reach. Compaction shall extend over the full width of the embankment and the material in the slopes shall be compacted as for the rest of structure. The work shall not be accepted until the trimming work and slope compacted using mechanical means like dozers, slope compactors, etc. to achieve a dry density not less than 95% of maximum dry density (Standard Proctor) for each. Slopes shall be maintained until final completion and acceptance. Any material that is lost by weathering or due to any other cause shall be replaced. The trimmed earth is permitted for reuse in the embankment under the classification of available excavated earth. No separate payment shall, however be made for forming extra width, offsets, slope compaction and trimming the slopes and the unit rates quoted for the embankment work shall, therefore, include for the same.

During the formation of side slopes every precaution shall be exercised by the Contractor to prevent slips. In case of such slips take place, the slipped material shall be removed & slope dressed to a modified stable slope, at no extra cost.

#### **Rates & Measurements**

##### **Rates**

- 1) The unit rate quoted for the formation of bund shall include the earth placing in layers, watering / dewatering, compacting the fill material as specified above.

- 2) It shall also include the cost of forming extra width of 0.50 m on both sides of embankment as specified above in clause “Formation of Extra width for adequate compaction” and dressing / trimming and compaction of slopes as specified in the clause “Dressing and Trimming of the Slopes”. The extra width of 0.50 m shall not be considered for payment.
- 3) It shall also include the cost of facilities for carrying out tests as required by DISTRICT PANCHAYAT, in approved laboratory as well as for conducting field tests.

**Measurements**

Measurement for formation of earthen embankment shall be in volume in **cubic meter** correct up to second place of decimal for payment by prismoid Al formulae. For calculating quantity of earthen embankment, the length of bund formed along the centerline shall be measured for correct to 1 cm. Before obtaining earth for the embankment from the borrow areas, the useful material excavated for the cut off trench and foundations of water escape structures, etc., shall be first utilized for forming of the embankment.

**Item No.10:**

**Providing, laying and spreading of compacted thickness of 200mm Hard Murrum and binding material to compact to the required density with 8 - 10 tonne vibratory roller , maintaining the required slope & grade during the operation as approved by the engineer in charge & watering to the proper moisture content and sprinkled with the help of truck mounted water tank fitted with suitable arrangement etc completed as per specification .**

**Scope**

This work shall consist of laying and compacting approved material on prepared sub grade/ stabilize base in accordance with the requirements of these Specifications. The material shall be laid in one or more layers as lower sub-base and (termed as sub-base hereinafter) as necessary according to lines, grades and cross-sections shown on the drawings or as directed by the Engineer.

**Materials**

The material to be used for the work shall be crushed gravel, crushed stone or combination thereof depending upon the requirement. The material shall be free from organic or other deleterious constituents.

**Construction Operation**

**Rolling**

Rolling shall be done with a 8-10 tonne roller/ 10-15 tonne vibratory. Rolling is continued till the required density achieved is at least 98 % of MDD the material determined by Proctor density as per IS 2720 Pt.VII) and a smooth surface obtained without leaving any roller marks on the surface. During rolling surface should be checked for grade and camber and irregularities corrected.

**Surface Irregularities**

The finish surface should be checked for line, level and grade and surface finish. The maximum permissible undulation in longitudinal profile shall not exceed 15 mm when checked with 3 meter straight edge and in cross profile the variation from specified profile shall not exceed 12 mm.

**Surface Finish and Quality Control of Work**

The surface finish of construction shall conform to the requirement as under:

Hard Murrum	CBR or unconfined Compressive Strength test on a set of 3specimens	As required/ Minimum one Test/1000m length
	Moisture content prior to compaction	One set of two tests per 500sqm
	Density of compacted layer	One set of two tests per 500sqm
	Deleterious constituents	As required

**Strength**

When hard murrum is used for improving the sub grade, the hard murrum material shall be tested for its CBR Value as per given in items description.

**Item No.11:**

**Providing & laying of 150mm compacted thickness Granular sub base (GSB) in grading V in table 400-1 of the specification MORT&H fifth revision and compactor to the required density with 8 - 10 tonne vibratory roller with plain drum or heavy pneumatic tyred roller of minimum 200 to 300 KN weight in all seasons as per MORT&H , maintaining the required slope & grade during the operation as approved by the engineer in charge & watering to the proper moisture content and sprinkled with the help of truck mounted water tank fitted with suitable arrangement .( fully saturated having CBR value greater or equal to 30)**

**Scope**

This work shall consist of laying and compacting well-graded material on prepared sub grade in accordance with the requirements of these Specifications. The material shall be laid in one or more layers as sub-base or lower sub-base and (termed as sub-base hereinafter) as necessary according to lines, grades and cross-sections shown on the drawings or as directed by the Engineer.

**Materials**

The material to be used for the work shall be crushed gravel, crushed stone or combination thereof depending upon the grading required. The material shall be free from organic or other deleterious constituents and shall conform to the grading given in Table 400-1 and physical requirements given in Table 400-2. The grading to be adopted for a project shall be as specified in the Contract. Where the sub-base is laid in two layers as upper sub-base and lower sub-base, the thickness of each layer shall not be less than 150mm.

If the water absorption of the aggregates determined as per IS: 2386(Part 3) is greater than 2 percent, the aggregates shall be tested for Wet Aggregate Impact Value (AIV) (IS:5640). Soft aggregates like Kankar, brick ballast and laterite shall also be tested for Wet AIV (IS:5640).

**Table 400-1: Grading for Granular Sub-base Materials**

IS Sieve Designation	Percent by Weight Passing the IS Sieve					
	Grading I	Grading II	Grading III	Grading IV	Grading V	Grading VI
75.0 mm	100	-	-	-	100	-
53.0 mm	80-100	100	100	100	80-100	100
26.5 mm	55-90	70-100	55-75	50-80	55-90	75-100
9.50 mm	35-65	50-80	-	-	35-65	55-75
4.75 mm	25-55	40-65	10-30	15-35	25-50	30-55
2.36 mm	20-40	30-50	-	-	10-20	10-25
0.85 mm	-	-	-	-	2-10	-
0.425 mm	10-15	10-15	-	-	0-5	0-8
0.075 mm	< 5	< 5	< 5	< 5	-	0-3

**Table 400-2 : Physical Requirements for Material for Granular Sub-base**

Aggregate Impact Value (AIV)	IS:2386 (Part 4) or IS:5640	40 maximum
Liquid Limit	IS:2720 (Part 5)	Maximum 25
Plasticity Index	IS:2720 (Part 5)	Maximum 6

CBR at 98% dry density (at IS:2720-Part 8)	IS:2720 (Part 5)	Minimum 30 unless otherwise specified in the Contract
--	------------------	---

### Construction Operations

#### Preparation of Sub-grade

Immediately prior to the laying of sub-base, the sub grade already finished to Clause 301 or 305 of MoRT&H Fifth Revision as applicable shall be prepared by removing all vegetation and other extraneous matter, lightly sprinkled with water, if necessary and rolled with two passes of 80-100 kN smooth wheeled roller.

#### Spreading and Compacting

The sub-base material of the grading specified in the Contract and water shall be mixed mechanically by a suitable mixer equipped with provision for controlled addition of water and mechanical mixing. So as to ensure homogenous sand uniform mix. The required water content shall be determined in accordance with IS: 2720 (Part 8). The mix shall be spread on the prepared sub grade with the help of a motor grader of adequate capacity, its blade having hydraulic controls suitable for initial adjustment and for maintaining the required slope and grade during the operation, or other means as approved by the Engineer.

Moisture content of the mix shall be checked in accordance with IS: 2720 (Part 2) and suitably adjusted so that, at the time of compaction, it is from 1 to 2 percent below the optimum moisture content.

Immediately after spreading the mix, rolling shall be done by an approved roller. If the thickness of the compacted layer does not exceed 100mm, a smooth wheeled roller of 80 to 100 kN weight may be used. For a compacted single layer up to 200mm the compaction shall be done with the help of a vibratory roller of minimum 80 to 100 KN static weight capable of achieving the required compaction. Rolling shall commence at the lower edge and proceed towards the upper edge longitudinally for portions having unidirectional cross fall or on super-elevation. For carriageway having cross fall on both sides, rolling shall commence at the edges and progress towards the crown.

Each pass of the roller shall uniformly overlap not less than one-third of the track made the preceding pass. During rolling, the grade and the cross fall (camber) shall be checked and any high spots or depressions which become apparent, corrected by removing or adding fresh material. The speed of the roller shall not exceed 5 km per hour.

Rolling shall be continued till the density achieved is at least 98 percent of the maximum dry density for the material determined as per IS:2720 (Part 8). The surface of any layer of material on completion of compaction shall be well closed, free from movement under compaction equipment and from compaction planes, ridges, cracks or loose material. All loose, segregated or otherwise defective areas shall be made to the full thickness of layer and re-compacted.

#### Surface Finish and Quality Control of Work

The surface finish of construction shall conform to the requirement of Clause 902 of MoRT & H Fifth Revision. Control on the quality of materials and works shall be exercised by the Engineer in accordance with Section 900 of MoRT&H Fifth Revision.

#### Table 900-3 Control Tests and their Minimum Frequency for Sub-Bases and Bases (Excluding Bitumen Bound Bases)

Sr. No & Type of Construction	Test	Frequency (min.)
1) Granular	Gradation	One test per 400 cum
	Atterberg Limits	One test per 400 cum
	Moisture content prior to compaction	One test per 400 cum
	Density of compacted layer	One test per 1000sqm
	Deleterious constituents	As required
	CBR	As required

**Control of alignment, level and surface regularity: -**

For checking GSB top surface levels shall be taken on a grid of points placed at 6.25 Mt. longitudinally and 3.5 Mt. transversely. For any 10 consecutive measurements taken longitudinally or transversely, not more than one measurement shall be permitted to exceed the tolerance given in table 900.1 of dense bituminous macadam item in this document. This one measurement being not in excess of 5 mm above the permitted tolerance.

**Arrangement for Traffic**

During the period of construction, arrangements for the traffic shall be provided and maintained in accordance with Clause 112 of MoRT&H Fifth Revision.

**Mode of Measurements for Payment**

Granular sub-base shall be measured as finished work in position in cubic meters. The protection of edges of granular sub-base extended over the full formation as shown in the drawing shall be considered incidental to the work of providing granular sub-base and as such no extra payment shall be made for the same.

GSB construction shall be measured separately by taking cross sections at suitable intervals in the original position before the work starts and after its completion and computing the volumes in **cubic meters**

**Rate**

The Contract unit rate for granular sub-base shall be payment in full for carrying out the required operation including full compensation for:

- i) Making arrangements for traffic to Clause 112 of MoRT&H Fifth Revision except for initial treatment to verges, shoulders and construction of diversion;
- ii) Supplying all materials to be incorporated in the work including all royalties, fess rents where applicable with all leads and lifts;
- iii) All labour, tools, equipment and incidentals to complete the work to the Specification;
- iv) Carrying out the work in part widths of road where directed; and
- v) Carrying out the required tests for quality control.

The rate shall be for a unit of one cubic meter.

**Item No.12:**

**Filling in foundation and plinth with murrum or selected soil in layers of 20cm. thickness including watering, ramming and consolidating etc. complete.**

**Material**

The Selected soil shall be confirm to M-63 and clean, of good binding quality, and of approved quality obtained from approved Pits / quarries of disintegrated rocks which contain siliceous material and natural mixture of yellow soil.

**Workmanship**

The Selected soil to be used for filling shall be free from salts, organic or other foreign matter. All cloud of the selected soil shall be broken.

As soon as the work in foundation has been completed and measured the site of foundation shall be cleared of all debris, bricks bats, mortar dropping etc. and filled with the selected soil in layers not exceeding 20 cms. Each layers shall be adequately watered, rammed and consolidated before the succeeding layer is laid. The murrum shall be rammed with iron rammers where feasible and with the butt ends of crowbars, where rammers cannot be used.

The plinth shall be similarly filled with the selected soil in layers not exceeding 20 cms. Adequately watered and consolidated by ramming with iron or wooden rammers. When filling reaches finished level, the surface shall be flooded with water for at least 24 hours and allowed to dry and then rammed and consolidated.

The finished level of filling shall be kept to shape intended to be given to the floor.

In case of large heavy duty flooring like factory flooring, the consolidation may be done by power rollers, where so specified. The extent of consolidation shall also be as specified.

The excavated stuff of the selected type shall be allowed to be used in filling the trenches and plinth. Under no circumstances black cotton soil shall be used for filling the plinth.

**Mode of measurement and payment**

The payment shall be made for filling in plinth and trenches. No deduction shall be made for shrinkage of voids if consolidated as instructed above.

The rate includes cost of collecting and carting the selected soil of approved quality with all lead and labour required for filling in trenches and plinth with consolidation.

The rate shall be for a unit of one cubic meter.

**Item No.13:**

**Refilling of Pipeline trenches**

**Refiling of the pipeline trenches/ foundation incl. ramming, watering , consolidating disposal of surplus stuff as directed within state limit as directed**

The detail specification to be followed as per Item No.12

**Item No.14:**

**Providing and filling sand and Lime mixture below R.C.C. Raft in Layers including ramming and watering complete.**

**Material**

The Selected lime shall be confirm to M-2 and sand shall be confirming to M-4.

**Proportion of Mix**

The Lime required in 1.00 Cum. Of Sand is 10% of Total Volume = 0.10 Cu.m.

**Workmanship**

Sand Lime mixture shall be filled in layers not exceeding 20 Cms. Each layer shall be adequately watered, rammed and consolidated before the succeeding layer is laid. The sand lime mixture shall be rammed with iron rammers where feasible and with the butt ends of crow-bars, where rammer cannot be used.

**Mode of measurement and payment:**

The payment shall be made for filling in foundation trenches. The rate includes cost of collecting carting sand and lime mix with all lead and labour for filling the same in plinth under floors.

The rate shall be for a unit of one cubic metre.

**Item No.15:**

**Providing and laying cement concrete 1:3:6 (1-Cement : 3- coarse sand : 6- hand broken stone aggregates 40 mm nominal size) and curing complete excluding cost of formwork in (A) Foundation and Plinth**

**Materials**

Water shall conform to M-1. Cement shall conform to M-3 Sand shall conform to M-4. Stone aggregate 40 mm nominal size shall conform to M-5A.

**Workmanship**

**General**

Before starting concreting the bed of foundation trenches shall be cleared of all loose materials, leveled, Watered and rammed as directed.

**Proportion of Mix**

The proportion of cement, sand coarse aggregate shall be one part of cement, 3 parts of sand 6 parts of stone aggregate shall be measured by volume.

**Mixing**

The concrete shall be mixed in a mechanical mixer is the site of work. Hand mixing may however be allowed for smaller quantity of work if approved by Engineer-in-charge. When hand mixing is permitted by the Engineer-in-charge in case of breakdown of machineries and in the interest of the work, it shall be carried out a water tight platform and care shall be taken to ensure that mixing is continued until the mass is uniform in colour and consistency. However in such case 10% more cement than otherwise required shall have to be used without any extra cost. The mixing in mechanical mixer shall be done for a period 1 to 2 minutes. The quantity of water shall be just sufficient to produce dense concrete of required workability for the purpose.

**Transporting and placing the concrete**

The concrete shall be handed from the place of mixing to the final position in not more than 15 minutes by the method as directed and shall be placed into its final position, compacted and finished within 30 minutes of mixing with water i.e. before the setting commences

The concrete shall be laid in layers of 15 cms to 20 cms.

**Compacting**

The concrete shall be rammed with heavy iron rammer and rapidly to get the required compaction and to allow the interstices to be filled with mortar.

**Curing**

After the final set, the concrete shall be kept continuously wet, if required by pending for a period of not less than 7 days from the date of placement.

**Mode of Measurements and Payment**

The concrete shall be measured for its length breadth and depth, limiting dimensions to those specified on plan or as directed.

The rate shall be for a unit of one cubic meter.

**Item No.16:**

**Providing & laying controlled cement concrete M200 and curing complete including the cost of formwork but excluding the cost of reinforcement for reinforced concrete work in (A) Foundation, footing, base of columns and Mass concrete.**

**Materials:**

Water shall conform to M-1. Cement shall conform to M-3. Sand shall conform to M-4, Grit shall conform to M-5. Coarse aggregate conform to M-5A

**General**

The concrete mix is not required to be designed by preliminary tests. The proportion of the concrete mix shall be 1:2:4 (1 cement: 2 coarse sand ; 4 graded stone aggregate 10 mm. nominal size) by volume. Concrete work shall have exposed concrete surface or as specified in the item.

The designation ordinary M-100, M-150, M-200, M-250 specified as per. I.S. Corresponding approximately to 1 : 3 : 6, 1 : 2 : 4, 1 : 1 <sup>1/2</sup> : 3 and 1:1:2 nominal mix of ordinary concrete by volume respectively.

The ingredients required for ordinary concrete containing one beg of cement of 50 Kg. by weight (0.0342 Cu. M.) for different proportions of mix shall be as under:

Grade of Concrete	Total quantity of dry aggregate by volume per 50 Kgs. of cement to be taken as the sum of individual volume of fine and coarse aggregates, maximum	Proportion of fine aggregate to the coarse aggregate	Quantity of water per 50 Kgs. of cement maximum.
1	2	3	4

M-100(1:3:6)	300 Liters	Generally 1:2 for fine aggregate to coarse aggregate by volume but subject to and upper limit of 1: 1 ½ and lower limit 1:3	34 Liters
M-150(1:2:4)	220 Liters		32 Liters
M-200(1:1 ½ :3)	160 Liters		30 Liters
M-250(1:1:2)	100 Liters		27 Liters

The water cement ratios shall not more than those specified in the above table. The cement content of the mix specified in the Table shall be increased if the quantity of water in a mix has to be increased to overcome the difficulties of placement and compaction so that the water-cement-ratio specified in the Table is not exceeded.

Workability of the concrete shall be controlled by maintaining a water-cement-ratio that is bound to give a concrete mix which is just sufficiently wet to be placed and compacted without difficulty with the means available.

The maximum size of coarse aggregate shall be as large as possible within the limits specified but in no case greater than one fourth of the minimum thickness of the member, provided that the concrete can be placed without difficulty so as to surround all reinforcement thoroughly and to fill the comers of the form.

For reinforced concrete work, coarse aggregates having a nominal size of 20 mm. are generally considered satisfactory.

For heavily reinforced concrete members as in the case of ribs of main beams, the nominal maximum size of coarse aggregate should usually be restricted to 5 mm. less than the minimum, clear distance between the main bars, or 5 mm. less than the minimum cover to the reinforcement whichever is smaller.

Where the reinforcement is widely spaced as in solid slabs, limitations of size of the aggregate may not be important and the nominal maximum size may sometimes be as great as OF greater than the minimum cover.

Admixture may be used in concrete only with approval of Engineer-in-charge based upon the evidence that with the passage of time, neither the compressive strength of concrete is reduced nor are other requisite qualities of concrete and steel impaired by the use of such admixtures.

The concrete mix shall be designed from preliminary tests, the proportioning of cement and aggregates shall be done by weight and necessary precautions shall be taken in the production to ensure that the required work cube strength is attained and maintained. The controlled concrete shall be in grades of M-100, M-150, M-200, M-250, M-300, M-350, & M-400, with prefix controlled added to it. The letter 'M' refers to mix and numbers specify 28 days works cube compressive strength of 150 mm. cubes of the mix expressed in Kg./Cmt.

The proportion of cement, sand and coarse aggregates shall be determined by weight, the weight batch machine shall be used for maintaining proper control over the proportion of aggregates as per mix design. The strength requirements of different grades of concrete shall be as under:

Grade of Concrete	Compressive strength of 15 cms. 28 days, conducted in accordance Preliminary test Work test. Min.	cubes in Kg./Cmt. At with I.S. 516-1959. Min.
M-150	200	150
M-200	260	200
M-250	320	250
M-300	380	300
M-350	440	350



M-400

500

400

In all cases, the 28 days compressive strength specified in above table above be the criteria for acceptance or rejection of the concrete.

Where the strength of a concrete mix as indicated by tests, lies in between the strength of any two grades specified in the above table, such concrete shall be classified in for all purposes-as concrete belonging to the lower of the two grades between which its strength lies.

### **Workmanship**

#### **The bars shall be kept in position by the following methods:**

In case of beam and slab construction, sufficient number of precast cover blocks in cement mortar 1:2(1 cement: 2coarse sand) about 4 cms. x 4 cms. section and of thickness equal to the specified cover shall be placed between the bars and shuttering as lo secure and maintain the requisite cover of concrete over the reinforcement.

In case of cantilevered or doubly reinforce beams of slabs, the main reinforcing bars shall be held in position by introducing chain spacers or supports bars at 1.0 to 1.2 metres centres.

In case of columns and walls, the vertical bars shall be kept in position by means of timber temphates with slotes accurately out in them The temphates shall be removed after concreting has been done below it. The bars may also be suitably tied by means of annealed steel wires to the shuttering to maintain their position during concreting.

All bars projecting from pillars, columns, beams, slabs, etc., to which other bars and concrete are to be attached or bounded to later on, shall be protected with a coat of thin neat cement grout, if the bars are not likely to be incorporated with succeeding mass of concrete within the following 10 days. This coat of thin neat cement shall be removed before concreting.

### **Proportioning**

Proportioning shall be done by volume, except cement which shall be measured in terms of bags of 50 Kg. weight. The volume of one such bag being taken as 0.0342 Cu. metre. Boxes of suitable sizes shall be used for measuring sand aggregate. The size of the boxes (internal) shall be 35 cms. x 25 cms. and 40 Cms. deep. While measuring the aggregate and sand, the box shall be filled without shaking ramming or hammering. The proportioning of sand shall be on the basis of its dry volume and in case of damp sand, allowances for bulkage shall be made.

The proportions for ingredients chosen shall be such that concrete has adequate workability for conditions prevailing on the work in question and can be properly compacted with means available except where it can be shown to the satisfaction of the Engineer-in-charge, that the supply of properly graded aggregate of uniform quality can be maintained till the completion of work. Grading of aggregate shall be controlled by obtaining the coarse aggregates, in different sizes and being in them in the right proportions as required. Aggregate of different sizes shall be stocked in separate stock piles. The required quantity of material shall be stock piled several hours, preferably a day before use. The grading of coarse and fine aggregate shall be checked as frequently as possible, the frequency for a given job being determined by the Engineer-in-charge to ensure that the suppliers are maintaining the uniform grading as approved for samples used in the preliminary tests.

In proportioning concrete, the quantity of both cement and aggregate shall be determined by weight. Where the weight of cement is determined by accepting the maker's weight per bag a reasonable number of bags shall be weighted separately to check the net weight. Where cement is weighted from bulk stocks at site and not by bags, it shall be weighted separately from the aggregates. Water shall either be measured by volume in calibrated tanks or weighed. All measuring equipment's shall be maintained in clean, and serviceable condition. Their accuracy shall be periodically checked.

It is most important to keep the specified water cement ratio constant and at its correct value. To this end, moisture content in both fine and coarse aggregates shall be determined by the Engineer-in-charge, according to the weather conditions. The amount of mixing water shall then be adjusted to compensate for

variations in the moisture content. For determination of moisture, content in the aggregates, I.S. 2389 (Part-III) shall be referred to. Suitable adjustments also be made in the weights of aggregates due to variation in their moisture content. Minimum quantity of cement used in concrete shall not be less than 220 Kg./M<sup>3</sup> in plain concrete and not less than 250 Kg./M<sup>3</sup> in reinforced concrete.

**Mixing:**

For all work, concrete shall "be mixed in a mechanical mixer which along with other accessories shall be kept in first class working condition and so maintained throughout the construction. Measured quantity of aggregate, sand, cement required for each batch shall be poured into the drum of the mechanical mixer while it is continuously running. After about half a minute of dry mixing, measured quantity of water required for each batch of concrete mix shall be added gradually and mixing continued for another one and a half minute. Mixing shall be continued till materials are uniformly distributed and uniform colour of the entire mass is obtained and each individual particle of the coarse aggregate shows complete coating of mortar containing its proportionate amount of cement. In no case shall the mixing be done for less than 2 minutes after all ingredients have been put into the mixer.

When hand mixing is permitted by the Engineer-in-charge for small jobs or for certain other reasons, it shall be done on the smooth watertight platform large enough to allow efficient turning over the ingredients of concrete before and after adding water. Mixing platform shall be so arranged that no foreign material gets mixed with concrete nor does the mixing water flow out. Cement in required number of bags shall be placed in a uniform layer on top of the measured quantity of fine and coarse aggregate, which shall also be spread in a layer of uniform thickness on the mixing platform. Dry coarse and fine aggregate and cement shall then be mixed thoroughly by turning over to get a mixture to uniform colour. Specified quantity of water shall then be added gradually through a rose-can and the mass turned over till a mix of required consistency is obtained. In hand mixing, quantity of cement shall be increased by 10 percent above that specified.

Mixers which have been out of use for more than 30 minutes shall be thoroughly cleaned before putting in a new batch. Unless otherwise agreed to by the Engineer-in-charge the first batch of concrete from the mixture shall contain only two thirds of normal quantity of coarse aggregate. Mixing plant shall be thoroughly cleaned before changing from one type of cement to another.

**Consistency:**

The degree of consistency which shall depend upon the nature of the work and methods of vibration of concrete, shall be determined by regular slump tests in accordance with I.S. 1199-1959. The slump of 10 mm. to 25 mm. shall be adopted when vibrators are used and 80 mm. when vibrators are not used.

**Inspection:**

Contractor shall give the Engineer-in-charge due notice before placing any concrete in the forms to permit him to inspect and accept the false work and forms as to their strength, alignment, and general fitness but such inspection shall not relieve the contractor of his responsibility for the safety of men, machinery, materials and for results obtained. Immediately before concreting, all forms shall be thoroughly cleaned.

Centering design and its erection shall be got approved from the Engineer-in-charge. One carpenter with helper shall invariably be kept present throughout the period of concreting. Movement of labour and other persons shall be totally prohibited for reinforcement laid in position. For access to different parts, suitable mobile platforms shall be provided so that steel reinforcement in position is not disturbed. For ensuring proper cover, mortar blocks of suitable size shim be cast and tied to the reinforcement. Timber, kapachi or metal pieces shall not be used for this purpose.

**Transporting and laying:**

The method of transporting and placing concrete shall be as approved. Concrete shall be so transported and placed that no contamination segregation or loss of its constituent material takes place.

All form work shall be cleaned and made free from standing water, dust, snow or ice immediately before placing of concrete. No concrete shall be, placed in any part of the structure until the approval of the Engineer-in-charge has been obtained.

Concreting shall proceed continuously over the area between construction joints. Fresh concrete shall not be placed against concrete which has been in position for more than 30 minutes unless a proper construction joint is formed. Concrete shall be compacted in its final position within 30 minutes of its discharge from the mixer. Except where otherwise agreed to by the Engineer-in-charge concrete shall be deposited in horizontal layers to a compacted depth of not more than 0.45 metre when internal vibrators are used and not exceeding 0.30 metre in all other cases.

Unless otherwise agreed to by the Engineer-in-charge, concrete shall not be dropped into place from a height exceeding 2 metres. When trucking or chutes are used they shall be kept close and used in such a way as to avoid segregation. When concreting has to be resumed on a surface which has hardened, it shall be roughened, swept clean, thoroughly wetted and covered with a 13 mm. thick layer of mortar composed of cement and sand in the same ratio as in the concrete mix itself. This 13 mm. layer of mortar shall be freshly mixed and placed immediately before placing of new concrete. Where concrete has not fully hardened, all laitance shall be removed by scrubbing the wet surface with wire or bristle brushes, care being taken to avoid dislodgement of any particles of coarse aggregate. The surface shall then be thoroughly wetted, all free water removed and then coated with neat cement grout. The first layer of concrete to be placed on this surface shall not exceed 150 mm. in thickness and shall be well rammed against old work, particular attention being given to corners and close spots.

All concrete shall be compacted to produce a dense homogeneous mass with the assistance of vibrators unless, otherwise permitted by the Engineer-in-charge for exceptional cases, such as concreting under water, where vibrators cannot be used. Sufficient vibrators in serviceable condition shall be kept at site so that spare equipment is always available in the event of breakdowns.

Concrete shall be judged to be compacted when the mortar fills the spaces between the coarse aggregate and begins to cream up to form an even surface. Compaction shall be completed before the initial setting starts i.e. within 30 minutes of addition of water to dry mixture. During compaction, it shall be observed that needle vibrators are not applied on reinforcement which is likely to destroy the bond between concrete and reinforcement.

**Curing:**

Immediately after compaction, concrete shall be protected from weather, including rain, running water, shocks, vibration, traffic, rapid temperature changes, frost and drying out process. It shall be covered with wet sacking, hassain or other similar absorbant material approved, soon after the initial set and shall be kept continuously wet for a period of not less than 14 days from the date of placement. Masonary work over foundation concrete may be started after 48 hours of its laying but curing of concrete shall be continued for a minimum period of 14 days.

**Sampling and Testing of concrete :**

Samples from fresh concrete shall be taken as per I.S. 1199-1959 and cubes shall be made, cured and tested at 7 days or 28 days as per requirements in accordance with I.S. 516-1959. A random sampling procedure shall be adopted to ensure that each concrete batch shall have a reasonable chance of being tested i.e. the sampling should be spread over the entire period of concreting and cover all mixing units. The minimum frequency of sampling of concrete of each grade shall be in accordance with following :

Quantity of concrete in the work	No. of samples	Quantity of concrete in the works	No. of samples
1-5 Cmt.	1	16-30Cmt.	3
6-15 Cmt.	2	31-50	4
51 and above 4 + one additional for each additional 50 M. or part thereof.			

**Note :** At least one sample shall be taken from each shift. Ten test specimens shall be made from each sample, five for testing at 7 days and the remaining five at 28 days. The samples of concrete shall be taken

on each day of the concreting as per above frequency. The number of specimens may be suitably increased as deemed necessary by the Engineer-in-charge when procedure of tests given above reveals a poor quality of concrete and in other special cases.

The average strength of the group of cubes cast for each day shall not be less than the specified cube strength of 150 Kg/Cm at 28 days. 20% of the cubes cast for each day may have value less than the specified strength provided the lowest value is not less than 85% of the specified strength. If the concrete made in accordance with the proportions given for a particular grade does not yield the specified strength, such concrete shall be classified as belonging to the appropriate lower grade concrete made in accordance with the proportions given for a particular grade shall not, however, be placed in a higher grade on the ground that the test strength are higher than the minimum specified.

**Stripping:**

The Engineer-in charge shall be informed in advance by the contractor of his intention to strike the form work. While fixing the time for removal of form work, due consideration shall be given to local conditions, character of the structure, the weather and other conditions that influence the setting of concrete and of the materials used in the mix. In normal circumstances (generally where temperatures are above 20 ° C) and where ordinary concrete is used, forms may be struck after expiry of periods specified in item No. 9.1 (A) for respective item of form work.

All form work shall be removed without causing any shock or vibration as would damage the concrete. Before the soffit and struts are removed, the concrete surface shall be exposed, where necessary in order to ascertain that the concrete has sufficiently hardened. Centring shall be gradually and uniformly lowered in such manner as to permit the concrete to take stresses due to its own weight uniformly and gradually. Where internal metal ties are permitted, they or their removable parts shall be extracted without causing any damage to the concrete and remaining holes filled with mortar. No permanently embedded metal part shall have less than 25 mm. cover to the finished concrete surface. Where it is intended to re-use the form work, it shall be cleaned and made good to the satisfaction of the Engineer-in-charge. After removal of form work and shuttering, the Executive Engineer shall inspect the work and satisfy by random checks that concrete produced is of good quality.

Immediately after the removal of forms, all exposed bolts etc., passing through the cement concrete member and used for shuttering or any other purpose shall be cut inside the cement concrete member to a depth of at least 25 mm. below the surface of the concrete and the resulting holes be filled by cement mortar. All fine caused by form joints, all cavities produced by the removal of form ties and all other holes and depressions honeycomb spots, broken edges or corners and other defects shall be thoroughly cleaned, saturated with water and carefully pointed and rendered true with mortar of cement and fine aggregate mixed in the proportions used in the grade of concrete that is-being finished and of as dry consistency as is possible to use. Considerable pressure shall be applied in filling and pointing to ensure thorough filling in all voids. Surfaces which are pointed shall be kept moist for a period of 24 hours.

If rock pockets/honeycombs in the opinion of the Engineer in-charge are of such an extent or character to affect the strength of the structure materially or to endanger the life of the steel reinforcement, he may declare the concrete defective and require the removal and replacement of the portions of the structure affected.

**Mode of measurement and payment:**

The consolidated cubical contents of concrete work as specified in item shall be measured. The concrete laid in excess of section shown on drawings or as directed shall not be measured. No deduction shall be made for

- (a) Ends of dissimilar materials such as joists, beams, posts, girders, rafters, purline trusses, corbels and steps etc up to 500 Sq. Cm. in section.
- (b) Opening up to 0.1 Sq. M.

The rate includes cost of all materials, labour, tools and plant required for mixing, placing, position, vibrating and compacting, finishing, as directed, curing and all other incidental expenses for producing concrete lied strength The rate excludes the cost of form work.

The volume occupied by reinforcement shall not be deducted from R.C.C. work.

The rate shall be for a unit of one cubic metre.

#### **Item No.17**

**Providing & laying controlled cement concrete M200 and curing complete including the cost of formwork but excluding the cost of reinforcement for reinforced concrete work in Column, Beam, Coping Etc.**

#### **Reinforced Cement Concrete (RCC) Mix Design ( M:20)**

The Contractor shall get the concrete mix designed confirming to various design parameters given in these specifications and latest revision of IS:10262 for each grade of concrete mentioned above by a Government approved laboratory. The cost / charge of the MIX DESIGN work shall be borne by the Contractor.

The MIX DESIGN shall be got approved from the engineer in charge. No volume batching shall be allowed at site. The concrete mix at site shall be The proportion of cement, sand and coarse aggregates, water and admixtures if any shall be determined by weight. The Contractor shall make arrangements to automatic batch mix plant at the site.

The Contractor shall follow the following specifications for mix design reinforced cement concrete work.

##### **1.1 Proportioning Mix:**

The mix of fine and coarse aggregate, cement and water as per the DESIGN MIX shall give the most dense concrete confirming to minimum quantity of cement paste and maximum water cement ratio for binding the materials to give required strength, Water content and the water cement ratio shall give the specified strength with the materials proposed for use in actual work carried out before the work is started, adopting the consistency suitable for the work and method of compaction that will be actually used on site subject to the water cement Ratio as Tabulated separately.

##### **1.2 Test:**

Tests shall confirm to the specifications laid down in I.S. 456 – 2000. These tests shall be got done in an approved laboratory at the cost of Contractor. **Target strength for M20 as per IS 456 latest version.**

##### a) Preliminary tests :

In preliminary test, three separate tests shall be carried out on samples collected from different stacks. Each test shall be carried out with six samples of 15 cm. (About 6”) cubes and 3 of these shall be tested at 7 days and 3 at 28 days. In preliminary tests the average crushing strength attained shall be 33 percent higher than that required on work tests.

##### b) Work test:

For each of the work test, 6 samples shall be prepared from the concrete being used on the site, 3 samples being tested at 7 days and the remaining 3 samples at 28 days. Work tests shall be carried out on each of the first six days and subsequently once in three working days or for every 60 cu.m. of concrete which ever is less and also whenever the quality or grading of the materials is changed. When a relation between the strengths at 7 days and 28 days is established, only 3 samples may be prepared and tested at 7 days only. This number of controlled specimen tests may be increased if the Engineer-in-charge considers it necessary.

##### **1.3 Field Mix :**

In the work tests, bulkage of sand due to moisture, if any, should be allowed for different batches according to the moisture actually present at the time of mixing. The moisture will be taken into account in controlling the mixing water also. The proportions once fixed by preliminary tests shall not be changed so long as the materials are the same, subject only to the quantities of fine aggregate and water being adjusted to compensate for bulkage due to the moisture in sand and free water in fine aggregate at the time of use. No change of materials shall be allowed unless fresh tests with new materials show satisfactory results.

Water and cement content per batch or concrete as determined MIX DESIGN shall be maintained constant except for suitable allowances to be made for surface moisture of the aggregates at the time of actual use. Immediately upon the receipt of the award of the contract, the Contractor shall inform the Engineer-in-charge the exact location of the sources of the acceptable materials which he proposes to use and get approved materials to be used. The CONCRETE MIX shall be got designed in an approved laboratory by the Contractor with minimum water cement ratio to give specified strength in the preliminary tests and the proportions got approved by the Engineer-in-charge in writing. These proportions shall be used so long as the materials contains to be of the same quality and from the same source subject only to slight changes in the relative quantities of fine and coarse aggregates for the purpose of promoting workability provided the works tests require the same. If during the progress of the work, the Contractor wishes to change the materials, the proportion shall be fixed on the basis of fresh MIX DESIGN to give the required strength after the Engineer-in-charge is satisfied that the materials satisfy the specifications. No adjustment of cost shall be made for change of proportions of cement fixed in the original preliminary tests.

#### 1.4 Maximum Water Cement Ratio :

Sr. No	Types of concrete	Mix Strength	Maximum Water Cement Ratio
1	Reinforced Concrete	M-30	0.45
		M-25	0.50
		M-20	0.55
		M-15	0.60

3.1.5 All structural members shall be kept continuously wet for a minimum period of 14 days by ponding and covering the surfaces by jute cloth and such other means.

#### DETAILED SPECIFICATONS FOR CONCRETE:

##### 2.1 INGREDIENTS

###### 1.Cement :

The cement shall be ordinary Portland Cement confirming to IS:269. Under special circumstances other cements may be used with prior approval of Engineer-in-charge. Cement shall conform to M-3

###### 2.Aggregate:

Aggregates shall comply with the requirements of IS:383. Generally aggregates having a nominal size of 20 mm shall be used. Coarse and Fine aggregate shall be weigh batched separately. Sand shall conform to M-4, Grit shall conform to M-5, Graded stone aggregate of design size shall confirm to M-5A and M-10.

###### 3.Water :

Water shall conform to M-1. Water used for mixing and curing shall be as per Clause 5.4 of IS:456-2000.

##### 2.2 Grades of concrete to be used shall be M20

Minimum cement content for different grades of concrete shall be as follows :

Grade	Minimum cement content in kg.
M-10	220
M-15	290
M-20	360
M-25	380
M-30	410

2.3 All reinforcement shall be free from loose mill scale, loose rust, and coats of paints, oil, mud or other coatings. The Contractor shall get the reinforcement cleaned by using wire brush, rubbing with gunny bags, light acid itching etc. as required.

2.4 Workability of concrete shall be as per Clause 6.0 of IS:456.

2.5 Durability :

In order to provide / produce durable concrete with low permeability, it must have an adequate cement content and a low water cement ratio. By using strong dense, aggregates, sufficient low water cement ratio,

ensuring thorough compaction and sufficient hydration of cement through proper curing methods, a sufficient low permeability is achieved. Therefore cement content shall be sufficient to provide adequate workability with a low water cement ratio so that concrete can be completely compacted with the means available.

The permissible limits of chlorides and sulphate in concrete shall be as per Table 1 of IS-456-2000.

### Concrete Mix Proportioning

The Concrete mix should be so proportioned that when the concrete is hardened it shall be of the required strength, durability and surface finish. For this purpose the Contractor shall establish a well equipped concrete testing laboratory at site. The results of these shall be sent to Consultant for their comments / approval / suggestion for modification of Design Mix.

### 3.1 Strength Requirement of Concrete :

Where ordinary Portland cement conforming to IS:269 or Portland blast furnace cement conforming to IS:455 is used, the compressive strength requirements for various grades of concrete, controlled as well as ordinary shall be as given in Table-1. Where rapid hardening Portland cement is used, the 28 days compressive strength requirement specified in Table-1 shall be met at 7 days. For controlled concrete, the mix shall be so designed as to attain in preliminary tests, a strength at least 33 percent higher than that required on work tests, for concrete mix up to and including M-25 and 25 percent higher for higher strengths. Preliminary tests need not be made in case of "ordinary concrete".

Table-1

Grade of concrete	Compressive work strength in Kg/cm <sup>2</sup> on 150 mm cubes as per Testing conducted in accordance with IS:516.	
	min.at 7 days	min.at 28 days
M-10	70	100
M-15	100	150
M-20	135	200
M-25	170	250
M-30	200	300
M-35	235	350

Note: In all cases, the 28 days compressive strength specified in Table-1 shall be the criterion for acceptance or rejection of the concrete.

When the strength of a concrete mix as indicated by test, lies in between the strength for any two grades specified in Table-1 such concrete shall be classified

for all purpose as concrete belonging to the lower of the two grades between which its strength lies.

Field Test cubes shall be taken as per IS 456 required / or directed by Engineer In Charge. The same shall be tested in approved laboratory & results shall comply with required strength of mix used. The cost of taking cubes and testing shall be included in rates quoted.

### 3.2 Nominal Mix Concrete:

Under special circumstances nominal mix concrete for grades of M20 or lower may be used with prior approval of Engineer-in-charge. Nominal Mix concrete shall be as per Table 9 of IS 456:2000

### Construction Tolerances

#### (a) Length

- |      |                                    |                 |
|------|------------------------------------|-----------------|
| (i)  | Members upto 3 mt length           | + 3mm to -6mm   |
|      | 3 mt to 4.5 mt length              | + 3mm to -8 mm  |
|      | More than 4.5 mt length            | + 3 mm to -10mm |
| (ii) | Cross-Sectional Dimensions         |                 |
|      | Dimensions up to 15 cm             | + 2mm           |
|      | Dimensions between 15 cm and 23 cm | + 3mm           |
|      | Dimensions greater than 23 cm      | + 4mm           |

- (b) Straightness : When a straight edge or line is applied to the member it shall not show concavity or convexity exceeding.
- |                           |        |
|---------------------------|--------|
| For length upto 4.5 mt    | 4.5 mm |
| For length between 4.5 mt | 6.0 mm |
| For length exceeding 6 mt | 8.0 mm |
- (c) Shape of Cross Section – No line on the cross section of a member shall deviate from its correct position by an angle exceeding 1 Degree. Vertical members shall not deviate in verticality from its true position by more than 5% of vertical length subject to maximum of 20 mm.  
Member which do not confirm to above mentioned constructional tolerances shall be removed and redone or modified / strengthened as per instructions of Engineer-in-charge / Consultant.

### **Specifications For Formwork, Centering And Scaffolding**

Materials :

Formwork shall be in plywood, sawn timber or steel as required for walls, stairs, slab, beams, columns, parapets, etc. for all concrete work.

Workmanship :

The formwork shall conform to the shape, lines and dimensions as shown on the drawings and shall be so constructed so as to remain sufficiently rigid and water-tight, during placement and compaction of the concrete. Adequate arrangement shall be made by the Contractor to safe guard against any settlements of the formwork during the course of concreting and after concreting.

Centering :

The centering, which has been got approved should be sufficiently strong and safe before, during and after pouring concrete and should be so erected that it would allow removal of forms in proper sequence without damaging either the concrete or the forms to be removed.

The props of centering shall be provided on firm foundation or base of sufficient strength to carry the loads, without any settlement.

Scaffolding :

All scaffolding, hoisting arrangements and ladders etc, required for facilitating of concrete shall be provided and removed on completion work by Contractor, at his own expense. The scaffolding, hoisting arrangement, ladders etc shall be strong enough to withstand all live, dead and impact loads expected to act. The Contractor shall be solely responsible for the safety of the scaffolding, hoisting arrangement, ladders, work and workmen etc.

The scaffolding, hoisting arrangement and ladders shall allow easy approach to the work spot and afford easy inspection.

### **Mode Of Measurement And Payment**

6.1 The Consolidated cubical contents of concrete work as specified in item shall be measured. The concrete laid in excess of section shown on drawings or as directed shall not be measured. No deductions shall be made for.

- a) Ends of dis-similar materials such as joints, beams, posts, girders, rafters, purlins, trusses, corbels and steps etc. up to 500 Sq. cm. in section.
- b) Opening up to 0.1 sq. m.
- c) The volume occupied by reinforcement shall not be deducted from R.C.C. work.

6.2 The rate include cost of all materials labour, tools and plant required for mixing, placing in position vibrating and compacting, finishing as directed, curing and all other incidental expenses as well as test charges for producing concrete of specified strength. The rate includes the cost of form work but excluding the cost of reinforcement.

6.3 The rate shall be for a unit of one **cubic meter**.



Providing form work of ordinary timber planking so as to give a rough finish including centering, shuttering strutting and propping etc. Height of propping and centering below supporting floor to ceiling and removal of the same for in site reinforced concrete and plain concrete work in [a] Foundation, footing Bases of columns [b] columns, [c] Beams [d] Slabs [e] Lintels [f] Chajjas [g] Staircases [h] Staircases Landings [i] Vertical and Horizontal fins [j] Mass concrete etc.comp.

**Materials :**

The shuttering to be provided shall be of ordinary timber planks and shall conform to M-26.

The dimensions of scantlings and battens shall conform to the dising. The strength of the wood shall not be less than that assumed in the design.

**Workmanship :**

8.1 The form work shall conform to the shape lines and dimensions as shown on the plans and be so constructed as to remain sufficiently rigid during the placing and compacting of the concrete. Adequate arrangements shall be made by the contractor to safe-guard against any settlement of the formwork during the course of concreting and after concreting. The form work of shuttering, centering, scaffolding, bracking etc. shall be as per design.

**Cleaning and Treatment of forms :**

8.3 All rubbish, particularly chippings shaving and saw dust shall be removed from the interior of the form before the concrete is placed and the form work in contact with concrete shall be cleaned and thoroughly wetted or treated. The surface shall be then coated with soap solution applied before concreting is done. Soap solution for the purpose shall be prepared by dissolving Yellow soap in water to get consistency of paint. Alternatively a coat of raw linseed oil/or form oil of approved manufacturer may be applied in case steel shuttering is used. Soap solution or raw linseed oil shall be applied after thoroughly cleaning the surface.

8.4 Care shall be taken that the coating does not get on construction joint surface and reinforcement bars.

**Stripping Time :**

In normal circumstances and where ordinary cement is used forms may be struck after expiry of following period :

	<b>Period</b>	
[a] Sides of wall columns and vertical faces of beams.	24 to 48 hours	
[b] Beams soffits [Props.left under]	07 days	
[c] Removal of props under slabs		
[i] Slabs spanning upto 4.5 Mt.	07 days	
[ii] Spanning over 4.5 Mt.	14 days	
[d] Removal of props to beams and Arches		
[i] Spanning upto 6 Mt.	14 days	
[ii] Spanning over 6 Mt.	21 days	

**Procedure when removing the form work :**

All form work shall be removed without such shock or vibrations as would damage the reinforced concrete surface. Before the soffit form work and struts are moved, the soffits and the concrete surface shall be exposed where necessary in order to ascertain that the concrete has sufficiently hardened.

**Centering :-**

11.1 The centering to be provided shall be got approved. It shall be sufficiently strong to ensure absolute safety of the form work and concrete work before, during and after pouring concrete. Watch should be kept to see that behaviour of centring and form work is satisfactory during concreting. Erection should also be such that it would all allow removal of forms in proper sequence without damaging either the concrete or the forms to be removed.

11.2 The props of centring shall be provided on firm foundation or base of sufficient strength to carry the loads without any settlement.

11.3 The centring and form work shall be inspected and approved by the Engineer-in-charge before concreting. But this will not relieve the contractor of his responsibility for strength, adequacy and safety of form work and centering.

11.4 If there is a failure of form work or centering, contractor shall be responsible for the damages to the work, injury to life and damage to property

**Scaffolding :-**

12.1 All scaffolding, hoisting arrangement and ladders etc. required for the facilitating of concreting shall be provided and removed on completion of work by contractor at his own expense. The scaffolding hoisting arrangement and ladders etc. shall be strong enough to withstand all live, dead and impact loads expected to act and shall be subject to the approval of the Engineer-in-charge. However, contractor shall be solely responsible for the safety of the scaffolding, hoisting arrangements, ladders, work and workmen etc.

12.2 The scaffolding, hoisting arrangements and ladders shall allow easy, approach to the work spot and afford easy inspection.

12.3 The rate is applicable to all conditions of working The rate shall include the cost of materials and labour for various operations involved such as :

[a] Splayed edges, notching, allowance for overlaps and passing at angle, battens centring, shuttering, propping bolting, Nailing, wedging, easing, striking and removal.

[b] Filletting to form stop chamfered edges of splayed external angles not exceeding 20 mm width to beams, columns and the like.

[c] Temporary openings in the forms for pouring concrete, if required, removing rubbish etc.

[d] Dressing with oil to prevent adhesion of concrete with shuttering, and

[e] Raking or circular cutting.

12.4 **Re-Use:-** Before- re- use all forms shall be inspected by Engineer-in-charge and their suitability ascertained. The forms shall be scarred, cleaned and joints gone over, repaired. Inside surface shall be retreated to prevent adhesion of concrete.

**Mode of measurement and payment :**

The Consolidated cubical contents of concrete work as specified in item shall be measured. The concrete laid in excess of section shown on drawings or as directed shall not be measured. No deductions shall be made for.

Ends of dis-similar materials such as joints, beams, posts, girders, rafters, purlins, trusses, corbels and steps etc. up to 500 Sq. cm. in section.

Opening up to 0.1 sq. m.

The volume occupied by reinforcement shall not be deducted from R.C.C. work.

The rate include cost of all materials labour, tools and plant required for mixing, placing in position vibrating and compacting, finishing as directed, curing and all other incidental expenses as well as test charges for producing concrete of specified strength. The rate includes the cost of form work but excluding the cost of reinforcement.

The rate shall be for a unit of one **cubic meter**.

**Item No. 18, 19 & 20**

**Providing & laying controlled cement concrete M250 and curing complete including the cost of formwork but excluding the cost of reinforcement for reinforced concrete work :**

**(A) For Foundation, Footing, Base of columns and Mass concrete.**

**(B) columns, pillars posts and struts, up to floor two level.**

**(C)Slabs, landing, shelves, Balconies, Lintels, Beams, Girders and Cantilever upto floor two level.**

The detail specification to be followed as per Item No.17

**Item no. 21****Providing TMT bar FE-500D reinforcement work including bending, binding & placing in position complete up to floor two level.****Materials**

Reinforcement shall conform to M-19 and Binding wire shall conform to M-21. Quality and grade of material to be procured shall be as mentioned in BOQ.

**Workmanship**

The work shall consist of furnishing and placing reinforcement to the shape and dimensions shown as on the drawing or as directed.

Steel shall be clean and free rust and loose mill scale at the time of fixing in a positions and subsequent concreting.

Reinforcing steel shall conform accurately to the dimensions given in the bar bending scheduled shown on relevant drawings. Bars shall be bent cold to specified shape and dimensions or /directed using a proper bar bender, operated by hand or power to attain proper radius of bends, Bars shall not be bent or straightened in matter that will injure the material. Bars bent during transport of handling shall be straightened before being used on the work. They shall not be heated to facilitate bending. Unless otherwise specified a "type hook at the end bar shall invariably be provided to main reinforcement. The radius of the bend shall not be less than twice the diameter of the bar beyond the end of the curve shall be at least four time the diameter of the round bar. In case of bars which are not round and in case of deformed bars, the diameter shall be takes as the diameter of circle having an equivalent effective area. The hooks shall be suitably excused to prevent any splitting of the concrete.

All the reinforcement bars shall be accurately placed in exact position shown on the drawings, and shall be securely held in position during placing of concrete by annealed binding wire not less than 1 mm in size and by using stay blocks or metal chair spacers, metal hanger supporting wires or other approved devices at sufficiently close intervals. Bars shall not be allowed to sag between supports nor displaced during concreting or any other operations of the work. All devices used for positioning shall be of no corrodible material. Wooden and metal supports shall not extent to the surface of concrete except where shown on drawings. Placing bars on layers of freshly laid concrete as the work progress for adjusting bar spacing shall not allowed. Pieces of broken stone or brick and wooden blocks shall not be used. Layers of bars shall be separated by spacer bars, precast mortar blocks or other approved devices, reinforcement after being placing position shall be maintained in a clean condition until completely embedded in concrete. Special care shall be exercised to prevent and displacement of reinforcement in concrete already placed. To prevent reinforcement from corrosion, concrete cove shall be provided as indicated on drawings. All the bars precluding from concrete and to which other areas to be splice and which are likely to be exceeding 10 days shall be protected by a thick cement of neat cement grout.

Bars crossing each other where required shall be secured by binding wires ( annealed ) of size not less than 1 mm in such a manner that they do not slip over each other at the time of fixing and concreting.

As far as possible, bars of full length shall be used. In case this is not possible, overlapping of bars shall be done as directed. When practicable overlapping bars shall not tough each other, but be kept part by 95 mm or 1.25 times the maximum size of the coarse aggregate whichever is greater by concrete between them. Where not feasible, overlapping bars shall be bound with annealed wires, not less than 1 mm thick twisted tight. The overlaps shall be staggered for different bars and located at points along then span where neither shear nor bending moment is maximum.

Whenever indicated on the drawing or desired by the Engineer-in-charge, bars shall be joint by couplings which shall have a cross-section sufficient to transmit the full stresses of bars. The ends of the bars that are joined by coupling shall be up set for sufficient length so not less than the nominal cross- section of the bar. Threads shall be standard threads. Steel for coupling shall conform to IS 226.

When permitted or specified on the drawings, joints of reinforcement. Bars shall butt-weld so as to transmit their full stresses. Welded joints shall preferably be located at points when steel will not be subject to more than more than 75 percent of the maximum permissible stresses and welds so staggered that at any one section not more than 20 percent of the rods are welded. Only electric arc welding a process which excludes air from the molten metal and conforms to any or all other special provisions for the work shall be accepted. Suitable means shall be provided for holding bars securely in position during welding. It shall be ensured that no voids are left in welding and when welding is done is two or three stages. Provisions surface shall be cleaned properly. Ends of the bars shall be cleaned of all loose scale, rust grease, paint and other foreign matter before welding. Only competent welders shall be employed on the work. The M.S. electrodes used for welding conform to IS 814 weld pieces of reinforcement shall be rested. Specimen shall be taken from the actual site and number and frequency of test shall be as directed.

Colds twisted steel bars shall be used with or without hooks at the ends. Deformed bars without hooks shall, however comply with relevant anchorage requirement.

#### **Mode of Measurement and Payment**

From the length so measured, the weight of reinforcement shall be calculated in kilograms on the same basis of as per, M-19 even though steel is supplied to the contractor by the department on actual weight. Length shall include hooks at the ends. Wastage and annealed steel wire for binding shall not be measured and the cost of these Descriptions be deemed to be included in the rate for reinforcement.

The rate for reinforcement includes cost of steel binding wires its carting from department store to site of work, including, cutting, bending, placing, binding, welding, lapping and fixing in position as shown on the drawings and as directed. It shall also include all devices for keeping reinforcement in approved positions, cost of joining as per approved method and all wastage and spacer bars.

The rate shall be for a unit of **one MT** of work completed. Without wastage

#### **Item No. 22**

**Providing and fixing remoulded compressible filler board in black colour confirming to MoRT&H Specifications (Clause 1015), having minimum density 95Kg./Cu.m. non-staining with less than 1% water absorption & compression recovery of 93% minimum as per specification for 20 mm wide expansion joint including cutting to required size and shape at all levels etc. complete as directed.**

The CAPCELL HD - 100 pre-moulded compressible filler board is black colour soft board impregnated with special grade of bitumen. It is a pre-moulded high performance joint filler board and made of from perfect base material for expansion joint filers and confirming to IS 1938 (part 1) 1983. Thickness of the pre-moulded joint filler shall be 25 m. unless otherwise specified.

The rate includes cost of all materials, labour, tools and plant required for placing in position, groove cutting, cleaning etc.

#### **Item No. 23**

**Providing and fixing pre-cast Rubber Dye / steel Dye inter locking concrete block 60mm thick with grade of concrete M300 pneumatic compressed / vibrated mechanically and as per approved design Confirming to IS 15658 : 2006 including 35 mm Sand layer for levelling and filling the joint with sand in proper line and level as per guidelines of IRC : SP 63-2018 etc. Complete.**

#### **Raw Material**

**Cement:-**

The cement used in the manufacture of high quality precast concrete paving block shall be conforming to IS 12269 (53 grade) ordinary Portland Cement or IS 8112 (43 grade ordinary Portland cement). The minimum cement content in concrete used for making paver blocks should be 310 kg/Cu.M. And the upper limit of cement shall not be more than 425kg/Cu.M.

**Aggregates :-**

The fine and coarse aggregates shall consist of naturally occurring crushed or uncrushed materials which, apart from the grading requirements comply with IS 383-1970. The fine aggregates used shall contain a minimum of 25% natural silicon sand. Lime stone aggregates shall not be used. Aggregates shall contain no more than 3% by weight of clay and shall be free from deleterious salts and contaminants.

**Water :-**

The water shall be clean and free from any deleterious matter. It shall meet the requirements stipulated in IS:456-2000.

**Other Materials :-**

Any other material/ingredients used in the concrete shall conform to latest IS specifications.

**Paver Blocks Characteristics**

The concrete pavers should have perpendicular ties after release from the mould and the same should be retained until the laying.

The surface should be of anti-skid and anti glare type. The paver should have uniform chamfers to facilitate easy drainage of surface run off.

The pavers should have uniform interlocking space of 2 mm to 3 mm to ensure compacted sand filling after vibration on the paver surface.

The concrete mix design should be followed for each batch of materials separately and automatic batching plant is to be used to achieve uniformity in strength and quality.

The pavers shall be manufactured in single layer only.

Skilled labour should be employed for laying blocks to ensure line and level for laying, desired shape of the surface and adequate compaction of the sand in the joints.

The pavers are to be skirted all round with kerbing using solid concrete blocks of size 100 mm x 200 mm x 400 mm or as directed by the Engineer. The kerbing should be embedded for 100 mm depth.

The concrete used for kerbing shall be cured properly for 7 days minimum.

**Laying Of Paver Blocks :-****Priming :-**

It will be responsibilities of the Contractors to ensure that the manhole/pipeline cable trenches/circular drainage system etc. raised to driveway level using the requisite materials as per instruction of Engineer incharge. The areas of potholes/deep depressions at the isolated locations also have to be filled up before laying the paver blocks. No extra payments will be made for this purpose.

It will be the responsibility of the Contractors to ensure that undulations on the paver blocks are eliminated after the traffic is allowed on it. Proper slope for drainage of water needs to be ensured by the Contractor. All necessary materials, tools, tackles are required to be arranged by the Contractor.

**Bedding Sand Course :-**

The bedding sand shall consist of a clean well graded sand passing through 4.75 mm sieve and suitable for concrete. The bedding should be from either a single source or blended to achieve the following grading.

In sieve size	% passed
9.52 mm	100
4.75 mm	95-100
2.36 mm	80-100

1.18 mm	60-100
600 microns	25-60
300 microns	10-30
150 microns	5 - 15
75 microns	0 - 10

Contractor shall be responsible to ensure that single-sized, gap graded sands or sands containing an excessive amount of fines or plastic fines are not used. The sand particles should preferably be sharp not rounded as sharp sand possess higher strength and resist the migration of sand from under the block to less frequently areas even though sharp sands are relatively more difficult to compact than rounded sands, the use of sharp sands is preferred for the more heavily trafficked driveways. The sand use for bedding shall be free of any deleterious soluble salts or other contaminants likely to cause efflorescence.

The sand shall be of uniform moisture content and within 4%-8% when spread and shall be protected against rain when stock piled prior to spreading. Saturated sand shall not be used. The bedding sand shall be spread loose in a uniform layer as per drawing. The compacted uniform thickness shall be of 45 mm and within +/- 5 mm. Thickness variation shall not be used to correct irregularities in the base course surface.

The spread sand shall be carefully maintained in a loose dry condition and protected against pre-compaction both prior to and following screeding. Any pre compacted sand or screeded sand left overnight shall be loosened before further laying of paving blocks take place.

Sand shall be slightly screeded in a loose condition to the predetermined depth only slightly ahead of the laying of paving unit.

Any depressions in the screeded sand exceeding 5 mm shall be loosened, raked and rescreeded before laying of paving blocks.

**Laying Of Interlocking Paver Blocks :-**

Paver blocks shall be laid in herringbone laying pattern throughout the pavement. Once the laying pattern has been established, it shall continue without interruption over the entire pavement surface. Cutting of blocks, the use of infill concrete or discontinuities in laying pattern is not be permitted in other than approved locations.

Paver blocks shall be placed on the uncompacted screeded sand bed to the nominated laying pattern, care being taken to maintain the specified bond through out the job. The first row shall be located next to an edge restraint. Specially manufactured edge paving blocks are permitted or edge blocks may be cut using a power saw, a mechanical or hydraulic guillotine, bolster or other approved cutting machine. Paver blocks shall be placed to achieve gaps nominally 2 to 3 mm wide between adjacent paving joints. No joint shall be less 1.5 mm not more than 4 mm. Frequent use of string lines shall be used to check alignment. In this regard the "laying face" shall be checked at least every two meters as the face proceeds. Should the face become out of alignment, it must be corrected prior to initial compaction and before further laying job is proceeded with.

In each row, all full blocked shall be laid first. Closure blocks shall be cut and fitted subsequently. Such closer blocks shall consist of not less than 25% of a full blocks.

To infill spaces between 25 mm and 50 mm wide concrete having screened sand, coarse aggregate mix shall be used. Within such mix the nominal aggregate size shall not exceed one third the smallest dimension of the infill space. For smaller spaces dry packed mortar shall be used.

Except where it is necessary to correct any minor variations occurring in the laying bond, the paver blocks shall not be hammered into position. Where adjustment of paver blocks necessary care shall be taken to avoid premature compaction of the sand bedding.

**Initial Compaction :-**

After laying the paver blocks, they shall be compacted to achieve consolidation of the sand bedding and brought to design levels and profiles by not less than Two (2) passes of a suitable plate compactor.

The compactor shall be a high-frequency, low amplitude mechanical flat plate vibrator having plate area sufficient to cover a minimum of twelve paving blocks. Prior to compaction all debris shall be removed from the surface.

Compaction shall proceed as closely as possible following laying and prior to any traffic. Compaction shall not, however, be attempted within one metre of the laying face. Compaction shall continue until lipping has been eliminated between adjoining blocks. Joints shall then be filled and recompact as described in Cl. 3.5.

All work further than one metre from the laying face shall be left fully compacted at the completion of each day's laying.

Any blocks that are structurally damaged prior to or during compaction shall be immediately removed and replaced.

Sufficient plate compactors shall be maintained at the paving site for both bedding compaction and joint filling.

**Joint Filling And Final Compaction :-**

As soon as possible after compaction and in any case prior to the termination of work on that day and prior to the acceptance of vehicular traffic, sand for joint filling shall be spread over the pavement. Joint sand shall pass a 2.36 mm (No.8) sieve and shall be free of soluble salts or contaminants likely to cause efflorescence. The same shall comply with the following grading limits.

In sieve size	% passed
2.36 mm	100
1.18 mm	90-100
600 microns	60-90
300 microns	30-60
150 microns	15-30
75 microns	10-20

The Contractor shall supply a sample of the jointing sand to be used in the contract prior to delivering any such materials to site for incorporation into the works. Certificates of test results issued by a recognized testing laboratory confirming that the samples conform to the requirements of this specifications shall accompany the sample.

The jointing sand shall be broomed to fill the joints. Excess sand shall then be removed from the pavement surface and the jointing sand shall be compacted with not less than one (1) Pass by the plate vibrator and joints refilled with sand to full depth.

This procedure shall be repeated until all joints are completed filled with sand. No traffic shall be permitted to use the pavement until all joints have been completely filled with sand and compacted. Both the sand and paver block shall be dry when sand is spread and broomed into the joints to prevent premature setting of sand.

The difference in level (lipping) between adjacent blocks shall not exceed 3 mm with not more than 1% in any 3 m x 3 mm area exceeding 2 mm. Pavement which is deformed beyond above limits after final compaction shall be taken out and reconstructed to the satisfaction of the Engineer.

**Edge Restraint :-**

Edge restrains need to be sufficiently robust to withstand override by the anticipated traffic, to withstand thermal expansion and to prevent loss of the laying course material from beneath the surface course. The edge restraint should present a vertical face down to the level of the underside of the laying course. The surface course should not be vibrated until the edge restraint, together with any bedding or concrete haunching, has gained sufficient strength. It is essential that edge restraints are adequately secured.

**Sampling And Testing Procedures For Paver Blocks :-****Sample Size:-**

Internal - Average of minimum 3 samples per 5000 blocks - for paver block manufacturers.

External - Minimum 2 blocks per 10000 blocks. Average of minimum 8 blocks per site - for captioned contractors.

**Sampling For Testing :-**

Sampling for testing of paver blocks shall be done in accordance with Appendix-A.

**Compressive Strength :-**

Testing for 28 days compressive strength shall be undertaken in accordance with Appendix-B. The average compressive strength of 60 mm thick paver blocks tested shall be 31.8 MPa.

Note:- 10% lower tolerance limit in compressive strength shall be allowed.

**Water Absorption :-**

Testing for water absorption shall be in accordance with IS 2185:1979:Part I (Specifications for concrete masonry blocks) Appendix C

**APPENDIX -A****Sampling Of Paver Blocks :-**

Method of Sampling:

The paver blocks required for carrying out the tests, a sample of 20 block shall be taken from every consignment of 4000 blocks or part thereof the same size, shape and thickness and the same batch of manufacture from these samples the blocks shall be taken at random for conducting the tests.

**Marking And Identification :-**

All samples shall be clearly marked at the time of sampling in such a way that the designated section of Part thereof and the consignment represented by the sample, are clearly defined.

The sample shall be dispatched to the approved test laboratory taking precaution to avoid damage to the paving in transit. Protect the paving from damage and contamination until they have been tested.

The samples shall be stored in water at 20°C + 5°C for 24 hours prior to testing.

**APPENDIX - B****Procedure For Testing Of Compressive Strength For Paver Block :**

Reference: BS 6717 Part I (1993) Specification for Paver Blocks B-1 Testing Machine: The testing machines shall be of suitable capacity for the test and capable of applying the load at the rate specified. It shall comply, as regards repeatability and accuracy with the requirements of relevant IS specification.

B-2 Procedure - The sample specimens shall be tested in wet condition after being stored at least 24 hours, in water maintained at a temperature of 20°C + 5°C before the specimens are submerged in water, the necessary area shall be determined.

The plates of the testing machine shall be wiped clean and any loose grit or other material removed from the contact faces of the specimen. Plywood nominally 4 mm thick, shall be used as packing between the upper and lower faces of the specimen and the machine plates, and these boards shall be larger than the specimen by a margin of at least 5 mm at all points. Fresh packing shall be used for



each specimen tested. The specimen shall be placed in the machine with the wearing surface in a horizontal plane and in such a way that the axes of the specimen are aligned with those of the machines plates. The load shall be applied without shock and increased continuously at the rate of approximately 15 N/sqmm per minute until no greater load can be sustained. The maximum load applied to the specimen shall be recorded.

**B-3 ALL CULATION OF CORRECTED STRENGTH:-**

The compressive strength of each block specimen shall be calculated by dividing the maximum load by full cross section area and multiplying by an appropriate factors.

Thickness and Chamfer Correction Factors

For Compressive Strength

Work Size		Correction Factors	
Thickness in mm		Plain Block	Chamfered
60	1.00	1.06	
80	1.12	1.18	
100	1.18	1.24	

**B-4 COMPRESSIVE STRENGTH CALCULATION:-**

The average corrected compressive strength for the designed block section shall be calculated.

**APPENDIX -C**

**Method For The Determination Of Water Absorption:-**

The test specimens shall be completely immersed in water at room temperature for 24 hours. The specimens shall then be weighed, while suspended by a metal wire and completely submerged in water. They shall be removed from the water and allowed to drain for one minute. Visible surfaces water being removed with a damp cloth and immediately weighed.

Subsequent to saturation, all specimens shall be dried in a ventilated oven at 100 to 115oC for not less than 24 hours and until two successive weightings at intervals of 2 hours show an increment of loss not greater, than 0.2 percent of the last previously determined mass of the specimen.

Calculate the absorption as follows:

$$\text{Absorption, kg/m}^3 \text{ A-B} = \frac{\text{A-B}}{\text{B-C}} \times 10000$$

$$\text{Absorption percent A-B} = \frac{\text{A-B}}{\text{B}} \times 100$$

- A = wet mass of unit in kg
- B = dry mass of unit in kg. And
- C = suspended immersed mass of unit in kg.

**Item No 24**

**A Pick and Carry Hydraulic Mobile Crane (Old Generation Hydra Crane with Rear Mounted Cabin) is a heavy-duty lifting machine with a hydraulic telescopic boom mounted on articulated chassis, powered by hydraulic systems for precise lifting and positioning of heavy loads in construction, agriculture, mining, forest, industry and others.**

**Engine Maximum Power Range at Rated RPM (kW) ≤ 37**

**Lift Capacity at one and a half mtr radius from center of front wheel should be 12000 kilogram**

**The vehicle should have Power Steering. Mounting of Cabin Rear mounted fully enclosed wide view cabin**

**The Boom should be in 3 Part hydraulically operated**

**Item No 25**

**Brick work using common burnt clay building bricks having crushing strength not less than 35 Kg./Sq.Cm. in Cement Mortar 1:6 (1- Cement : 6 -fine sand)(B) Conventional  
(A) In Foundation and Plinth**

**Materials:**

Water shall conform to M-1. Cement shall conform to M-3. Sand shall conform to M-4. Brick shall conform to M-9. Cement mortar shall conform to M-7.

**Workmanship:****Proportion:**

The proportion of the cement mortar shall be 1:6 (1 cement: 6 fine sand) by volume.

**Wetting of bricks:**

The bricks required for masonry shall be thoroughly wetted with clean water for about two hours before use or as directed. The cessation of bubbles, when the bricks are wetted with water is in indication of through wetting of bricks.

**Laying:**

Bricks shall be laid in English bond unless directed otherwise. Half or cut bricks shall not be used except when necessary to complete to bond; closers in such case shall be cut to required size and used near the ends of walls.

A layer of mortar shall be spread on full width for suitable length of the lower course. Each brick shall first be properly bedded and set home by gently tapping with handle of trowel or wooden mallet. Its laid face shall be flushed with mortar before the next brick is laid and pressed against it. On completion of course, the vertical joints shall be filled from the top with mortar.

The walls shall be taken up truly in plumb. All courses shall be laid truly horizontal and all vertical joint shall be truly vertical. Vertical joints in alternate course shall generally be directly one over the other. The thickness of brick course shall be kept uniform.

The brick shall be laid with frog upwards. A set of tools comprising of wooden straight edges, mason's spirit level, square half metre rub, and pins, string and plumb shall be kept on the site of work for frequent checking during the progress of work.

Both the faces of walls of thickness greater than 23 cms. Shall be kept in proper place. All the connected brick work shall be kept not more than one metre over the rest of the work. Where this is not possible the work shall be raked back according to bond (and not left toothed) at an angle not steeper than 45 degrees. All fixtures, pipes outlets of water, hold fasts of doors and windows etc. which are required to be unit in wall shall be embedded in cement mortar.

**Joints:**

Bricks shall be so laid that all joints are quite flush with mortar. Thickness of joints shall not exceed 12 mm. The face joints shall be raked out as directed by taking tools daily during the progress of work, when the mortar is still green so as to provide key for plaster or pointing to done.

The face of brick shall be cleaned the very day on which the brick work is laid and all mortar dropping removed.

**Curing:**

Green work shall be protected from rain suitably. Masonry work shall be kept moist on all the faces for a period of seven days. The top of masonry work shall be kept well wetted at the close of the day.

**Preparation of foundation bed:**

If the foundation is to be laid directly on the excavated bed, the bed shall be levelled, cleared of all loose materials, cleaned and wetted before starting masonry. If masonry is to be laid on concrete footing, the top of concrete shall be cleaned and moistened. The contractor shall obtain the engineer's approval for the foundation bed, before foundation masonry is started. When pacca flooring is to be provided flush with the top to plinth, the inside plinth offset shall be kept lower than the outside plinth top by the thickness of the flooring.

**Mode of measurements and payment:**

The measurements of this item shall be taken for the brick masonry fully completed in foundation up to plinth. The limiting dimensions not exceeding those shown on the plans or as directed shall be final. Battered, tapered and curved portions shall be measured net.

No deductions shall be made from the quantity of brick work, nor any extra payment made for embedding in masonry or making holes in respect of following items: (1) Ends of joints, beams. Posts, girders, rafters, purlins, trusses, corbel steps etc. where cross sectional area does not exceed 500 Sq. Cm. (2) Opening not exceeding 1000 Sq. Cm. (3) Wall plates and bed plates, bearing of slabs, chhajjas and the like whose thickness does not exceed 10 cms. and the bearing does not extend to the full thickness of wall. (4) Drainage holes, and recesses for cement concrete blocks to embed hold fasts for doors, windows etc. (5) Iron fixtures, pipes up to 300 mm. dia hold fasts and doors and windows built into masonry and pipes etc for concealed wiring. (6) Forming chases of section not exceeding 350 Sq. Cm. in masonry.

Apertures for fire places shall not be deducted nor shall extra labour required to make splaying of jambs, throating and making Arches over the aperture be paid for separately.

The rate shall be for a unit of one **cubic metre**.

**Item No. 26**

**(B) In Superstructure above plinth level up to floor two level**

The relevant specification should be followed by Item No. 25

**Item No. 27**

**Filling available excavated earth (excluding rock) in trenches. plinth, sides of foundations etc. in layers not exceeding 20 cm. in depth consolidating each deposited layer by ramming and watering.**

**Workmanship:**

The earth to be used for filling shall be free from salts, organic or other foreign matter. All clods of earth shall be broken.

As soon as the work in foundation has been completed and measured, the site of foundation shall be cleared of all debris bricks bats, mortar dropping etc. and filled with earth in layer not exceeding 20 cms. Each layer shall be adequately watered rammed and consolidated before the succeeding layer is laid. The earth shall be rammed with iron rammers where feasible and with the butt ends of crowbars, where rammer cannot be used.

The plinth shall be similarly filled with earth in layer not exceeding 20 cms. Adequately watered and consolidated by ramming with iron or wooden rammers, when filling reaches finished level, the surface shall be flooded with water for at least 24 hours and allowed to dry and then rammed and consolidated.

The finished level of filling shall be kept to shape intended to be given to floor.

In case of large heavy-duty flooring like factory flooring, the consolidation may be done by power rollers; where so specified. The extent of consolidation required shall also be as specified.

The excavated stuff of the selected type shall be allowed to be used in filling the trenches and plinth. Under no circumstances black cotton soil be used for filling the plinth.

**Mode of measurement and payment:**

The payment shall be made for filling in plinth and trenches. No deduction shall be made for shrinkage or voids if consolidated as instructed above.

The rate shall be for a unit of one cubic meter.

**Item No. 28**

**Cement Plaster (20 mm thick)**

**A) Cement plaster 20 mm thick in C.M. 1:2 using water proofing compound of approved quality including finishing etc. complete.**

**Materials:-**

Water shall conform to M-1 cement mortar shall conform to M-7.

**Workmanship:-**

The work of 20 mm thick plaster shall be carried out in two coats whereas 10 to 15 mm thick plaster work shall be carried out in single coat. If BOQ mentions, water proofing compound shall be mixed in cement mortar at a rate as specified by manufacturer of compound during application of both coats.

When plaster thickness is up to 15 mm, it shall be applied in one coat. Ratio and thickness of cement mortar shall be as per BOQ.

For 20 mm thick plaster work, the backing coat [basecoat] shall be 12 mm thick. Ratio of cement mortar shall be as per BOQ for both coats. Before the first coat hardens its surface shall be beaten up by edges of wooden tappers and close dents shall be made on the surface subsequent coat shall be applied after this coat has been allowed to set for 3 to 5 days, depending upon the weather conditions. The surface shall not be allowed to dry during this period.

The second coat shall be completed to 8 mm thickness in C.M. 1:1 as described above, including raising sand facing by bushing. The sample of sand face plaster shall be got approved before the work is started. The whole work shall be carried out uniformly as per sample approved.

**Curing:-**

The curing shall be started overnight after finishing of plaster. The plaster shall be kept wet for a period of 7 days. During this period, it shall be protected from all damages.

**Mode of Measurements and payment:-**

Plaster work in above ground level shall be measured and paid under this item on Sqm basis.

**Item No. 29**

**Providing 10mm thick cement plaster in single coat on brick/concrete walls for interior plastering upto floor two level and finished even and smooth in (i)Cement mortar 1:3 (1-cement:3-sand)**

The relevant specification should be followed by Item No. 28

**Item No. 30**

**Providing 15mm thick cement plaster in single coat on Rough (Similar)side of single or half brick walls for interior plastering upto floor two level and finished even and smooth in (i) Cement mortar 1:3 (1-cement:3-sand)**

The relevant specification should be followed by Item No. 28

**Item No. 31**

**20mm thick sand faced cement plaster on walls upto height 10 metres above ground level consisting of 12mm thick backing coat of C.M. 1:3 (1-cement : 3-sand) and 8mm thick finishing coat of C.M. 1:1 (1-cement : 1-sand) etc. complete.**

The relevant specification should be followed by Item No. 28

**Item No. 32**

**Finishing wall with water proofing cement paint of on wall surfaces (Three coats) to give an approved brand and manufacture and of required shape even shade after thoroughly brushing the surface to remove all dirt and remains of loose powered materials.**

**Materials**

The water shall conform to M-1. Cement water proofing shall conform to I.S. 5410-1969

**Scaffolding**

Wherever scaffolding is necessary it shall be erected in such a way that as far as possible on part of scaffolding shall rest against the surface to be white or colour washed. A properly secured strong and well tied suspended platform (Zoola) may be used for white washing. Where ladders are used, pieces of old gunny bag shall be used at top and bottom to prevent scratches to the floors and walls. For white washing of coatings proper stage scaffolding shall be erected where necessary.

**Preparation of surface**

The surface shall be thoroughly cleaned of all dust, dirt, mortar cropping and other foreign matter before white wash is to be applied.

The surface spoiled by smoke soot shall be scraped with steel wire brushes or steel scrapers or shall be rubbed with over-burnt surkhi or brick bats. The surface shall be then broomed to remove all dust, dirt and shall be washed with clean water.

Oil or grease spots shall be removed by suitable chemical and smooth surface shall be rubbed with wire brushes.

All unsound portion of the surface plaster shall be removed to full depth of plaster in rectangular patches and plastered again after raking the masonry joints properly. Such portion shall be wetted and allowed to dry. They shall then be given one coat of white wash.

All unnecessary nails shall be removed; the holes cracks patches etc. shall be made good with materials similar in composition to the surface to be prepared.

The colour wash shall be submitted with water proofing cement paint. The surface shall be thoroughly wetted with clean water before cement water proofing paint is applied.

**Preparation of paint**

Portland cement shall be prepared by adding paint power to water and stirring to obtain a thick paste, which shall then be diluted to a brush able consistency. Generally equal volumes to paint powder and water make a satisfactory paint. In all cases, the manufacturer's instructions shall be followed. The paint shall be mixed in such quantities as can be used up within an hour of mixing as otherwise the mixture will set and thickness, affecting flowing and finish. The lids of cement paint drums shall be kept tightly when not in use.

**Application of paint**

No painting shall be done when the paint is likely to be exposed to a temperature of below 70 C with 48 hours after application.

When weather conditions are such as to cause damage the work shall be carried out "in the shadow" as far as possible. This helps the proper hardening of the paint film by keeping the surface moist for a longer period.

To maintain the uniform mixture and to prevent segregation, the paint shall be stirred frequently in the bucket.

For undecorated surfaces, after the primer coat is dried for at least 48 hours the surfaces shall be lightly sand papered to make them smooth for receiving the distemper, taking care not to rub cut the priming coat. All loose particles shall be dusted off after rubbing. Minimum two coats of distemper shall be applied with brushes in horizontal strokes followed immediately by vertical strokes which together shall constitute one coat. The subsequent coats shall be applied after time interval of at least 24 hours between consecutive coats to permit proper drying of the preceding coat. The finished surfaces shall be even and uniform without patches, brush marks; distemper drops etc.

The finished surface shall be even and uniform in shade, without patches, brush marks, paint drops etc.

The cement paint shall be applied with a brush with relatively short stiff hog or fiber bristles. The paint shall be brushed in uniform thickness and shall be free from excessive heavy brush marks.

The lamps shall be well brushed out.

Water proof cement paint shall not be applied on surface already treated with white wash colour wash, distemper dry or oil bound varnishes, paint etc. It shall not be applied on gypsum, wood or metal surfaces.

#### **Curing**

Painted surfaces shall be sprinkled with water two or three times a day. This shall be done between coats and for at least two days following the final coat. The curing shall be started as soon as the paint has hardened so as not to be damaged by sprinkling of water say about 12 hours after the application.

#### **Preparation of surface.**

The surface shall be thoroughly cleaned of all dust, dirt, mortar cropping and other foreign matter before white wash is to be applied.

The surface spoiled by smoke soot shall be scraped with steel wire brushes or steel scrapers or shall be rubbed with over-burnt surkhi or brick bats. The surface shall be then broomed to remove all dust, dirt and shall be washed with clean water.

Oil or grease spots shall be removed by suitable chemical and smooth surface shall be rubbed with wire brushes.

All unsound portion of the surface plaster shall be removed to full depth of plaster in rectangular patches and plastered again after raking the masonry joints properly. Such portion shall be wetted and allowed to dry. They shall then be given one coat of white wash.

All unnecessary nails shall be removed; the holes cracks patches etc. shall be made good with materials similar in composition to the surface to be prepared.

#### **Mode of measurements & payments**

All the work shall be measured in the decimal system as under:  
(a) Dimensions shall be measured to the nearest 0.01 M.

(b) Area in individual Descriptions shall be worked out to the nearest 0.01 Sq.M

All the work shall be measured in Sq.mt. Deductions for jambs, soffits, sills, etc. for opening not exceeding 0.5 sq.mt. each in area for ends of joints, posts, beams, girders steps etc. not exceeding 0.5 sq.mt. each in area and for opening exceeding 0.3 sq.mt. and not exceeding 3.0 sq.mt. each in area deduction and additions shall be made as under.

No deductions shall be made for ends of joints beams, posts etc. and opening not exceeding 0.5 sq.mt. each. No addition shall be made on reveals, jambs, soffits sills etc of these opening nor for finish around ends of joints beams posts etc.

Deduction for opening exceeding 0.5 sq.mt. but not exceeding 3 sq.mt. each shall be made as follows and no addition shall be made for reveals, jambs, soffits etc. of these openings

(a) When both the faces or walls are provided with finish, deduction shall be made for one face only.

(b) When each faces of wall is provided with different finish deduction shall be made for that side of frame for door, windows etc. on which width of reveals is less than that of the other side, where width or reveals

on both faces of wall are equal, deduction of 50% of area of opening on each face shall be made from total area of finish.

(c) When only one face of wall is treated and the other face is not treated, full deduction shall be made if the width of reveal on the treated side is less than that on the untreated side, but if the width of the reveal is equal or more than one the untreated side neither deductions nor additions be made for reveals, jambs, soffits, sills etc.

In case of area of opening exceeding 3 sq.mt each deduction shall be made for opening but jambs, soffits, shall be measured.

No deductions shall be made for attachment such as casing, pipe, conducts, electric wiring and the like.

Corrugated surfaces shall be measured flat as fixed and not girth. The quantities so measured shall be increased by the following percentage and the resultant shall be included with the general areas.

- (a) Corrugated steel sheets 14%
- (b) Corrugated A.C. Sheet 20%
- (c) Semi corrugated A.C.Sheets 10%
- (d) Nainital pattern roof (Plain sheeting with rolls ) 10%
- (e) Nainiital pattern roof (with corrugated sheet) 25%

Cornices and other wall features, when they are not picked out in a different finish / colour shall be girthed and included in the general area.

The rate shall include the cost of all materials labour, scaffolding, protective measures etc. involved in all the operations described above.

The rate shall be for a unit of one Square meter.

### **Item No. 33**

**Wall painting (two coats) with plastic emulsion paint of approved brand and manufacture on under corated wall surface to give an even shade including thoroughly brushing the surface free from mortar droppings and other foreign matter and sand papered smooth.**

#### **Materials**

Water shall conform to M-1. The plastic emulsion shall conform to I.S. 5411-1969 (part I)

#### **Workmanship**

#### **Scaffolding**

Wherever scaffolding is necessary it shall be erected in such a way that as far as possible on part of scaffolding shall rest against the surface to be plastic emulsion paint. A properly secured strong and well tied suspended platform (Zoola) may be used for plastic emulsion paint. Where ladders are used, pieces of old gunny bag shall be used at top and bottom to prevent scratches to the floors and walls. For plastic emulsion paint of coatings proper stage scaffolding shall be erected where necessary

#### **Preparation of surface**

The surface shall be thoroughly cleaned of all dust, dirt , mortar cropping and other foreign matter before plastic emulsion paint is to be applied.

The surface spoiled by smoke soot shall be scraped with steel wire brushes or steel scrapers or shall be rubbed with over-burnt surkhi or brick bats. The surface shall be then broomed to remove all dust, dirt and shall be washed with clean water.

Oil or grease spots shall be removed by suitable chemical and smooth surface shall be rubbed with wire brushes.

All unsound portion of the surface plaster shall be removed to full depth of plaster in rectangular patches and plastered again after raking the masonry joints properly. Such portion shall be wetted and allowed to dry. They shall then be given one coat of white wash.

All unnecessary nails shall be removed, the holes cracks patches etc. shall be made good with materials similar in composition to the surface to be prepared.

**Preparation of mix**

This shall be done as per manufacturer's instructions. The thinning of emulsion is to be done with water and not with turpentine. The quantity of thinner to be added shall be as per manufacture instructions.

**Application**

Before pouring into small containers for use, the paint shall be stirred thoroughly in its container. When applying also the paint shall be continuously stirred in the smaller container, so that its consistency is kept uniform.

The paint shall be laid on evenly and smoothly by means of crossing and laying off the crossing and laying off consist of covering the area over with paint, brushing the surface hard for the first time over and then brushing alternately in opposite direction two or three times and then finally brushing lightly in a direction at right angles to the same. In this process, no brush marks shall be left after the laying off is finished. No hair marks from the brush or clogging of paint puddles in the corners of panels, angles of mouldings etc. shall be left on the work. The full process of crossing and laying off will constitute one coat.

The paint shall be applied with brush or rollers. For undecorated surfaces, the surface shall be treated with minimum two coats of cement water proofing paint. The second or subsequent coat shall not be started until the preceding coat has become sufficiently hard to resist marking by brush being used.

The surface on finishing shall present a flat velvety smooth finish. It shall be even and uniform in shade without patches, brush marks paint drops etc.

**Precautions**

(a) Old brushes if they are to be used with emulsion paints shall be completely dried of turpentine oil paint by washing in warm soap water. Brushes shall be quickly washed in water immediately after use and kept immersed in water during break periods to prevent the paint from hardening on the brush.

(b) In the preparation of wall for plastic emulsion painting. No oil base putties shall be used in filling cracks holes etc. (c) Splashes on floor etc. shall be cleaned out without delay as they will be difficult to remove after hardening. (d) Washing of surfaces treated with emulsion paint shall not be done within 3 to 4 weeks of application.

**Protective measures**

The surface of doors, windows, floors, articles of furniture etc. and such other parts of the building not to be white washed shall be protected from being splashed upon. Such surfaces shall be cleaned of white wash splashed if any.

**Mode of measurements & payments**

All the work shall be measured in the decimal system as under:

(a) Dimensions shall be measured to the nearest 0.01 M.

(b) Area in individual Descriptions shall be worked out the nearest 0.01 Sq.M

All the work shall be measured in Sq.mt. Deductions for jambs, soffits, sills, etc. for opening not exceeding 0.5 sq.mt. each in area for ends of joints, posts, beams, girders steps etc. not exceeding 0.5 sq.mt. each in area and for opening exceeding 0.3 sq.mt. and not exceeding 3.0 sq.mt. each in area deduction and additions shall be made as under.

No deductions shall be made for ends of joints beams, posts etc. and opening not exceeding 0.5 sq.mt. each. No. addition shall be made on reveals, jambs, soffits sills etc of these opening nor for finish around ends of joints beams posts etc.

Deduction for opening exceeding 0.5 sq.mt. but not exceeding 3 sq.mt. each shall be made as follows and no addition shall be made for reveals, jambs, soffits etc. of these openings (a) When both the faces or walls are provided with finish, deduction shall be made for one face only. (b) When each faces of wall is provided with different finish deduction shall be made for that side of frame for door, windows etc. on which width of reveals is less than that of the other side, where width or reveals on both faces of wall are equal, deduction of 50% of area of opening on each face shall be made from total area of finish.



(C) When only one face of wall is treated and the other face is not treated, full deduction shall be made if the width of reveal on the treated side is less than that on the untreated side, but if the width of the reveal is equal or more than one the untreated side neither deductions nor additions be made for reveals, jambs, soffits, sills etc.

In case of area of opening exceeding 3 sq.mt each deduction shall be made for opening but jambs, soffits, shall be measured.

No deductions shall be made for attachment such as casing, pipe, conducts, electric wiring and the like.

Corrugated surfaces shall be measured flat as fixed and not girth. The quantities so measured shall be increased by the following percentage and the resultant shall be included with the general areas.

(a) Corrugated steel sheets 14%

(b) Corrugated A.C. Sheet 20%

(c) Semi corrugated A.C.Sheets 10%

(d) Nainital pattern roof (Plain sheeting with rolls ) 10%

(e) Nainital pattern roof (with corrugated sheet) 25%

Cornices and other wall features, when they are not picked out in a different finish / colour shall be girthed and included in the general area.

The rate shall include the cost of all materials labour, scaffolding, protective measures etc. involved in all the operations described above.

The rate shall be for unit of one Square meter.

#### **Item No. 34**

**Providing and applying Epoxy paint of approved make to concrete surface for RCC ESR of GSR or any other structure including cleaning the surface by scrapping and air blowers to the satisfaction of Engineer-in-charge necessary scaffolding etc. complete with all leads and lifts and giving satisfactory hydraulic test for water tightness as per IS codes.**

#### **Material:**

The waterproofing material shall be a polymer modified cementitious coating or any other approved liquid applied seamless coating. The material should confirm to water permeability test (Depth of penetration at 5 bar pressure) where no leakage should occur after 24 hours as per EN 12390, part 8:2000 or as per IS 2645:2003 test methods.

#### **Surface Preparation**

- RCC kerb of 100 mm high to be constructed at floor level at all masonry wall to prevent migration of moisture into dry areas.
- Waterproofing should extend up to 150 mm into dry area covering the kerb surface
- Angle fillet (corner rounding) of 50 mm x 50 mm shall be done using polymer modified mortar at all horizontal and vertical junctions (floor & wall junction) along with screed mixed with waterproofing compound.
- Angle fillet (corner rounding) of 25 mm x 25 shall be done using polymer modified mortar at all horizontal and vertical junctions (sunken floor, sunken bath tub etc.) along with screed mixed with waterproofing compound.
- Surfaces to be applied upon must be clean, reasonably dry, free from dirt, loose material, oil & grease and be as smooth as possible.
- Honeycombing in concrete should be filled with polymer modified grouts before applying any surface patch material.
- Slope of the surface to be checked before applying waterproofing material

### **3. Sealing the gap around plumbing fixtures**

- All PVC pipes should be wrapped with double sided bituminous tape, at the place where they go through the wall or floor.
- The gap between wrapped pipe and wall and gaps around Nahani traps, pipe outlets should be filled with ready to use free flowing non-shrink cementitious grout.
- All concealed pipelines should be filled with polymer modified mortar.
- Ensure the water tightness of plumbing system with pressure test and do any rectification for leakages if any.
- Complete all plumbing and sanitation work before commencement of waterproofing works

### **4. Waterproofing Application**

- Surface should be pre-wetted to make surface saturated dry (SSD) condition.
- Apply by brush or roller a coat of a polymer modified cementitious liquid applied seamless waterproofing coating at a specified coverage per kg to all required areas to achieve a thickness of 500 – 600 micron in one coat and allow the surface to dry for 4 -6 hours.
- Apply second coat in the opposite direction at the same rate. After the application of second coat, the total thickness of membrane should be 1 to 1.2 mm. The treatment is left as it is for 48 hours for air cure before carrying out ponding test.
- At the floor & wall joint junction provide a glass fibre mesh cut to size covering the fillet area laid to size and shape followed by 2nd coat of waterproofing for additional protection.
- Sprinkle coarse sand after the 2nd coat application while it is still wet for providing a key for subsequent tile adhesive material.
- The waterproofing shall be carried at least 300 mm on vertical surfaces above the floor finish level except the splash zone of shower where the waterproofing should be carried out to 1.8 to 2.1 m height in bathroom and toilets. In other wet areas the vertical surface should be waterproofed for a minimum height of 150 mm.
- The coating shall be applied to the internals of the down pipes for minimum 50 mm down to the floor outlet before laying of the tiles, bedding and floor traps.

### **5. Ponding Test**

- Ponding test shall be carried out at a depth of 50 mm for 48 hours to determine the water tightness after closing all the outlets. Necessary remedial actions should be taken for any seepage or leakage of water. The waterproofing shall be considered satisfactory, if no leaks or damp patches show on the soffit.

### **6. Protective Screed**

- Upon successful completion of the ponding test, a layer of 10mm Cement/Sand (Ratio 1:4) protective screed, using an integral waterproofing compound shall be applied on top of the membrane.
- If the drainage pipes are laid on the floor the minimum thickness of screed should be 20 mm.
- The floor level should be provided with adequate slope considering the pipe thickness.
- Care shall be taken whilst laying the protective screed so as not to damage the waterproofing membrane below.
- The contractor shall take all measures necessary to prevent any damage to the membrane or protective screed during subsequent work

#### **Material:**

The paint shall be of approved quality and 100 micron thickness shall be applied.

#### **Workmanship:**

**Scaffolding**

Wherever scaffolding is necessary it shall be erected in such a way that as far as possible on part of scaffolding shall rest against the surface to be white or color washed. A properly secured strong and well tied suspended platform (Zoola) may be used for white washing. Where ladders are used, pieces of old gunny bag shall be used at top and bottom to prevent scratches to the floors and walls. For white washing of coatings proper stage scaffolding shall be erected where necessary.

**Preparation of surface**

The surface shall be thoroughly cleaned of all dust, dirt, mortar cropping and other foreign matter before primer coat is to be applied.

The surface spoiled by smoke soot shall be scraped with steel wire brushes or steel scrapers or shall be rubbed with over-burnt surkhi or brick bats. The surface shall be then broomed to remove all dust, dirt and shall be washed with clean water.

Oil or grease spots shall be removed by suitable chemical and smooth surface shall be rubbed with wire brushes.

All unsound portion of the surface plaster shall be removed to full depth of plaster in rectangular patches and plastered again after raking the masonry joints properly. Such portion shall be wetted and allowed to dry. They shall then be given one coat of colour wash.

All unnecessary nails shall be removed; the holes cracks patches etc. shall be made good with materials similar in composition to the surface to be prepared.

The colour wash shall be submitted with water proofing cement paint. The surface shall be thoroughly wetted with clean water before cement water proofing paint is applied.

**Preparation of paint**

Epoxy paint shall be prepared as per manufacturer's specification.

**Application of paint**

No painting shall be done when the paint is likely to be exposed to a temperature of below 70 C with 48 hours after application.

When weather conditions are such as to cause damage the work shall be carried out "in the shadow" as far as possible. This helps the proper hardening of the paint film by keeping the surface moist for a longer period.

To maintain the uniform mixture and to prevent segregation, the paint shall be stirred frequently in the bucket.

For undecorated surfaces, after the primer coat is dried for at least 48 hours the surfaces shall be lightly sand papered to make them smooth for receiving the distemper, taking care not to rub cut the priming coat. All loose particles shall be dusted off after rubbing. Minimum two coats of distemper shall be applied with brushes in horizontal strokes followed immediately by vertical strokes which together shall constitute one coat. The subsequent coats shall be applied after time interval of at least 24 hours between consecutive coats to permit proper drying of the preceding coat. The finished surfaces shall be even and uniform without patches, brush marks; distemper drops etc.

The finished surface shall be even and uniform in shade, without patches, brush marks, paint drops etc.

The epoxy paint shall be applied with a brush with relatively short stiff hog or fibre bristles. The paint shall be brushed in uniform thickness and shall be free from excessive heavy brush marks.

Epoxy cement paint shall not be applied on surface already treated with white wash, colour wash, distemper dry or oil bound varnishes, paint etc. It shall not be applied on gypsum, wood or metal surfaces.

**Curing**

Painted surfaces shall be sprinkled with water two or three times a day. This shall be done between coats and for at least two days following the final coat. The curing shall be started as soon as the paint has handened so as not to be damages by sprinkling of water sahy about 12 hours after the application.

**Mode of measurements & payments:**

All the work shall be measured in the decimal system as under:

- (a) Dimensions shall be measured to the nearest 0.01 meter.
- (b) Area in individual Descriptions shall be worked out the nearest 0.01 Sq.meter.

All the work shall be measured in Sq.mt. Deductions for jambs, soffits, sills, etc. for opening not exceeding 0.5 sq.mt. each in area for ends of joints, posts, beams, girders steps etc. not exceeding 0.5 Sq.mt. each in area and for opening exceeding 0.3 Sq.mt. and not exceeding 3.0 Sq.mt. each in area deduction and additions shall be made as under.

No deductions shall be made for ends of joints beams, posts etc. and opening not exceeding 0.5 Sq.mt. each No. addition shall be made on reveals, jambs, soffits sills etc of these opening nor for finish around ends of joints beams posts etc.

Deduction for opening exceeding 0.5 sq.mt. but not exceeding 3 sq.mt. each shall be made as follows and no addition shall be made for reveals, jambs, soffits etc. of these openings

When both the faces or walls are provided with finish, deduction shall be made for one face only.

When each faces of wall is provided with different finish deduction shall be made for that sideof frame for door, windows etc. on which width of reveals is less than that of the other side, where width or reveals on both faces of wall are equal, deduction of 50% of area of opening on each face shall be made from total area of finish.

When only one face of wall is tested and the other face is not treated, full deduction shall be made if the width of reveal on the treated side is less than that on the untreated side, but if the width of the reveal is equal or more than one the untreated side neither deductions nor additions be made for reveals, jambs, soffits, sills etc.

In case of area of opening exceeding 3 sq.mt each deduction shall be made for opening but jambs, soffits, shall be measured.

No deductions shall be made for attachment such as casing, pipe, conducts, electric wiring and the like.

- Corrugated surfaces shall be measured flat as fixed and not girth. The quantities so measured shall be increased by the following percentage and the resultant shall be included with the general areas.
- Corrugated steel sheets 14%
- Corrugated A.C. Sheet 20%
- Semi corrugated A.C.Sheets 10%
- Nainital pattern roof (Plain sheeting with rolls ) 10%
- Nainiital pattern roof (with corrugated sheet) 25%

Cornices and other wall features, when they are not picked out in a different finish / colour shall be girthed and included in the general area.

The rate shall include the cost of all materials labour, scaffolding, protective measures etc. involved in all the operations described above.

The rate shall be for a unit of one Square meter.

**Item No. 35**

**Constructing a cooking platform 60 cm. width and 70 cm high resting on B.B. Masonry walls 23 cm. thick in C.M.(1:6) with (ii) Fixing black kadappa stone 30mm thick laid on precast R.C.C. (1:2:4) slab with plastering on exposed faces of wall in C.M. (1:4) etc complete.**

**Materials:**

Water shall conform to M-1 Cement shall conform to M-3 Sand shall conform to M-4 Burnt brick shall conform to M-9. Marble mosaic chips shall conform to M-30 Stone aggregate 20 mm nominal size shall conform to M-5A and M.S. bars shall conform to M-11

**Workmanship:**

The cooking platform of size as directed shall be constructed in 60-cms.width and 70cms height. The brick masonry wall in C.M. 1:6 shall be constructed in 23 cm thickness up to full depth. The relevant specifications of Description 18 shall be followed for masonry work.

The RCC slab of 8 cms thickness and of adequate design and size shall be precast and the same shall be put up on the BB masonry work.

The top and exposed sides of the RCC slab shall be finished with mosaic terrazzo 8mm thick with required color pigment. The work of Kota stone shall be carried out as per relevant specification of Description 28

The whole masonry work shall be finished with cement mortar in C.M. 1:4

**Mode of Measurements and payment**

The work of cooking platform shall be measured for finished work.

The rate includes cost of all labor and materials, etc. required for satisfactory completion of this Description as described above.

The rate shall be for a unit of one Running meter.

**Item No. 36**

**Providing and laying polished Kota stone slab flooring over 20mm (Average) thick base of cement mortar 1:6 (1-cement : 6-coarse sand) or L.M. 1.1.5 (1-Lime putty :1.5 - coarse sand) laid over and jointed with grey cement slurry mixed with pigment to match the shade of slab including rubbing and polishing etc. complete. (A) 25mm thick**

**Materials**

Water shall conform to M-1. Cement shall conform to M-3 sand conform to M-4. Cement mortar shall conform to M-7. Polished Kota stone M-32.

**Workmanship**

Each slab shall be cut to the required size and shape and fine chisel dressed at all the edges. The sides thus dressed shall have a full contact if a straight edge is laid along. The sides shall be table rubbed with coarse sand before paving. All angles and edges of the slabs shall be true square and free from chippings and giving a plane surface. The thickness shall be 25 mm. (Average) as specified in the Description but not less than 20 mm. at any place of the slab.

Bedding for the kotah stone slabs shall be cement mortar 1:6 (1 cement: 6 coarse sand) or L.M. 1:1.5. of average thickness 20 mm. as given in the description of the Description. Sub grade shall be cleaned, wetted and mopped. Mortar of the specified mix and thickness shall be then be spread on an area sufficient to receive one kotah stone slab. The slab shall be washed clean before laying. It shall be laid on top pressed, tapped gently to bring it in level with the other slabs. It shall then be lifted and laid aside. Top surface of the mortar shall then be corrected by adding fresh mortar at hollows or depressions. The mortar shall then be allowed to harden bit. Over this surface, cement slurry of honey like consistency shall be applied. The slab shall then be gently placed in position and tapped with wooden mallet till it is properly padded in level with and close to the adjoining slab. The joint shall be as fine as possible. The slabs fixed in the floor adjoining the wall shall enter not less than 10 mm. under the plaster, skirting or dado. The junction between the wall floor shall be finished neatly. The finished surface shall be true to levels and slopes as directed.

The floor shall be kept wet for a minimum period of 7 days. So that bedding and joints set properly.

Polishing shall be normally commenced after 14 days of laying the stone slab. First polishing shall be done with carborundum stones of 120 grade grit fitted in the heavy machine and then second polishing shall be done with carborundum stone Of 220 to 350 grade grit fitted in heavy machine.

Water shall be properly used during polishing. The stone shall then be washed clean with water. When directed by the Engineer-in-charge wax polish of approved quality shall be applied on the surface with the help of soft cloth over a clean and dry surface. Then the polish machine fitted with bobs shall be run over it.

The holes required for Nahni traps, pipes any other fittings shall be made without any extra cost.

**Mode of measurements & payment:**

The rate shall include the cost of all materials and labour involved in all the operations described above. The kota stone flooring shall be measured in square meters correct to two places of decimal, length and breadth shall be measured correct to a centimeter and between the finished face of skirting dado or wall plaster and no deduction shall be made nor extra paid for any opening in floor of areas up to 0.1 sq. mt. The rate shall be for a unit of one Square meter.

**Item No. 37**

**Providing and laying polished Kota stone slab flooring over 20mm (Average) thick base of cement mortar 1:6 (1-cement : 6-coarse sand) or L.M. 1.1.5 laid over and jointed with grey cement slurry including rubbing and polishing etc. complete. (B) 30 mm thick**

**Materials**

The slabs shall be of approved selected quality, hard, sound, dense and homogenous in texture, free from cracks, decay, weathering and flaws. The percentage of water absorption shall not exceed 5 percent as per test conducted in accordance with IS : 1124.

The slabs shall be hand or machine cut to the required thickness. Tolerance in thickness for dimensions of tile more than 100mm shall be  $\pm 5$ mm. This shall be  $\pm 2$ mm on dimensions less than 100mm.

Slabs shall be supplied to the specified size with machine cut edges or fine chisel dressed to the full depth. All angles and edges of the slabs shall be true and square, free from any chipping giving a plane surface. Slabs shall have the top surface machine polished (first grinding) before being brought to site. The slabs shall be washed clean before laying.

**Workmanship**

The type, size, thickness and colour/shade etc. of the slabs for flooring/dado/skirting shall be as specified in the respective items of works prepared by the Contractor.

**Preparation of the concrete base**

If the kota stone is to be laid directly on the excavated bed, the bed shall be leveled, cleared of all loose materials, closed, wetted and placed concrete in ratio 1:3:6 of 100 mm thickness. Once, the concrete is dried up, the top of concrete shall be cleaned and moistened. The contractor shall obtain the engineer's approval for the foundation bed, before flooring is started. Care shall be taken to provide slope in flooring one point as directed by EIC and to keep top of base at inside lower than the outside plinth top by the thickness of the flooring.

The thickness of the slabs for dado/skirting work shall not be more than 25mm. Slabs shall be so placed that the back surface is at a distance of 12mm. If necessary, slabs shall be held in position temporarily by suitable method. After checking for verticality, the gap shall be filled and packed with cement sand mortar of proportion 1:3. After the mortar has acquired sufficient strength, the temporary arrangement holding the slab shall be removed.

Grinding and polishing shall be as per direction and satisfaction of EIC except that first grinding with coarse grade carborundum shall not be done and cement slurry with or without pigment shall not applied before polishing.

**Item No. 38**

**Providing and laying Ceramic tiles 6mm thick in flooring treads of steps and landing laid on a bed of 12mm thick cement mortar 1:3 (1-cement : 3-coarse sand ) finishing with flush pointing in white cement.**

**For flooring works- All Floor**

**Materials**

Water shall conform to M-1. White cement shall conform to M-3A, Cement mortar shall conform to M-11, while ceramic tiles shall conform to latest revision of IS 13630 Part 1 to 15.

**Workmanship**

The work shall be carried out as per I.S.1443-1972. Testing of the tiles shall be carried out by the contractor at his own cost as per I.S. requirement for required tests.

**Bedding** - The sub-grade shall be cleaned, wetted and mopped. The bedding shall then be laid evenly over the surface tamped and corrected to desired levels and allowed to harden enough to offer a rigid cushion to tiles and to enable the mason to place wooden planks across and squat on it.

The ceramic tiles shall be laid on cement mortar bedding of 12mm. thick in C.M. 1:3. The mortar shall have sufficient plasticity for laying and there shall be no hard lumps that would interfere with the evenness of bedding. The base shall be cleared and well wetted. The mortar shall then be spread in thickness. The proportion of the cement mortar shall be as specified in the item.

**Fixing Tiles** - The edges of the tiles shall be well pressed and gently tapped with a wooden mallet till they are properly bedded and in level with the adjoining tiles. There shall be no hollows in bed or joints. The joints between the tiles shall be as thin as possible in straight line or as per pattern.

Before laying the ceramic tiles, the tiles shall be thoroughly wetted with water. Neat cement grout of required consistency at 4.4 kg. cement/sq.mt. shall be spread on the mortar bed. The tiles shall be laid on the neat cement float and shall be evenly and firmly bedded to the required level and slopes. There shall be no hollows left. The joints shall be of uniform thickness and in straight line as per the pattern. The surface of flooring shall be checked frequently with a straight edge at-least two meters long so as to obtain a true surface with required slope

The tiles shall not have staggered joints. The joints shall be there to center line both ways. The nahn trap coming in the flooring shall be so positioned that its grating shall replace only one tile as far as possible. Where full size tiles cannot be fixed. They shall be cut (swan) to the required size and the edge rubbed smooth to ensure straight and true joints. The joints shall be filled with grey cement grout with wire, brush or trowel to a depth of 5mm. and loose material removed. White cement shall be used for pointing the joints. After fixing the finally in an even plane the flooring shall be kept wet and allowed to stay undisturbed for 7 days.

The tiles which are fixed in the adjoining the wall shall go about 10 mm under plaster. Skirting or dedo shall be left unfinished for about 50 mm above finished floor level and unfinished strip then left earlier shall be finished In places where full tiles can not be fixed. The tiles shall be cut to the size and smoothed at edges to give straight and true joints.

After the tiles have been laid, the surplus cement slurry and the joints shall be cleaned and washed fairly deep before cement hardens.

The day after tiles have been laid, the joints shall be cleaned of every cement grout with a wire brush to a depth of about 5 mm and then grouted with white cement with or without pigment to match the shade of the topping of tiler.

**Cleaning** - The surplus cement grout that may have come out of the joints shall be cleared off before it sets. Once the floor has set, it shall be carefully washed, cleared by dilute acid and dried. Proper precautions and measures shall be taken to ensure that the tiles are not damaged in any way till the completion of the construction.

**Mode Of Measurements & Payments.**

The work done shall be measured in sq.Mts. for visible area of work done. The length and width of the flooring shall be work done. The length and width of the flooring shall be measured between the faces of skirting or dados or plastered face of wall as the case may be. The paving under dedo or skirting shall not be measured. No deductions shall be made for extra paid for any opening in the floor of are upto 0.1 Sq.Mts. Nothing extra shall be paid for laying the floors at different levels in the same rooms. The rate shall include the cost of all materials, labour involved in all the operations as described above.

The rate shall be for a unit of one Square Meter.

**Item No. 39**

**Providing and laying white glazed tiles 6mm thick in flooring treads of steps and landing laid on a bed of 12mm thick cement mortar 1:3 (1-cement : 3-coarse sand) finishing with flush pointing in white cement.**

**Materials**

Water shall conform to M-1. White cement shall conform to M-3A. Cement mortar shall conform to M-7. Ceramic and glazed tiles shall conform to latest revision of I.S. 13630 (part: 1 to 15) and I.S. 777 respectively.

**Workmanship****Bedding**

The sub grade shall be cleaned, wetted and mopped. The bedding shall then be laid evenly over the surface tamped and corrected to desired levels and allowed to harden enough to offer a rigid cushion to tiles and to enable the mason to place wooden planks across and squat on it. The white glazed tiles shall be laid on cement mortar bedding of 12 mm. thick in C.M. 1:3. the mortar shall have sufficient plasticity for laying and there shall be no hard lumps that would interfere with the evenness of bedding. The base shall be cleared and well wetted. The mortar shall then be spread in thickness not less than 10 mm. at any place and on an average 12 mm. thickness. The proportion of the cement mortar shall be as specified in the Description.

Fixing tiles- the tiles before lying shall be soaked in water for at least two hours. Neat gray cement grout. At 3.3 Kgs/cement/Sq.Mts. of honey like consistency shall be spread over the mortar bedding as directed. The edges of the. Tiles shall be well pressed and gently tapped with a wooden mallet till they are properly bedded and in level with the adjoining tiles. There shall be no hollows in bed or joints. The joints between the tiles shall be as thin as possible in straight line or as per pattern.

The tiles shall not have staggered joints. The joints shall be there to center line both ways. The nahn trap coming in the flooring shall be so positioned that its trap coming in the flooring shall be so positioned that its grating shall replace only one tile as far as possible. Where full size tiles cannot be fixed, they shall be cut (swan) to the required size and the edge rubbed smooth to ensure straight and true joints. The joints shall be filled with gray cement grout with wire, brush or trowel to a depth of 5 mm. and loose material removed. White cement shall be used for pointing the joints. After fixing the tiles finally in an even plane the flooring shall be kept wet and allowed to stay undisturbed for 7 days.

Cleaning – the surplus cement grout that may have come out of the joints shall be cleared off before it sets. Once the floor has set, it shall be carefully washed, cleared by dilute acid and dried. Proper precautions and measures shall be taken to ensure that the tiles are not damaged in any may till the completion of the construction.

**Item No. 40**

**Providing and laying white glazed tiles 6mm thick in skirting risers of steps and dedo on 10mm thick cement plaster 1:3 (1 cement : 3-coarse sand) and jointed with white cement slurry**

**Materials**



Water shall conform to M-1. Cement mortar shall conform to M-7. White glazed tiles shall conform to M-33.

#### **Workmanship**

**Preparation of Surface** - In case of brick masonry work, the joints shall be taken out to a depth of at least 15 mm. The surface shall be chiseled and roughened with wire brushes. The surface shall be cleaned and wetted thoroughly before commencing the laying work.

**Laying** - The wall surface shall be covered with 10mm. thick plaster of cement mortar 1:3 mix and allowed to harden. The Plaster shall be roughened with wire brushes both ways. The back of tiles shall be floated with grey cement slurry and edges with white cement slurry set in bedding mortar. The tiles shall be gently tapped in position one after the other keeping the joints as thin as possible. Dedo shall be truly horizontal and the joints vertical row as per the required pattern.

Risers of steps, skirting and dedo shall rest on top of treads or flooring. Where full size tiles cannot be fixed, they shall be cut to the required size and the edges to be smoothed.

The joints shall be cleaned and flush point with white cement. The surface shall be kept wet for seven days. after curing the surface shall be washed clean.

#### **Mode Of Measurements & Payments**

The rate shall include the cost of all materials and labour required for various operations described above. Risers of steps, skirting and dedo shall be measured in Sq. Mts. Length and height shall be measured along the finished face of the skirting or dedo including and external angles etc. used. The length and height shall be measured correct to the cms. except in case of risers and skirting where height shall be measured correct to 3mm.

The Rate shall be for a unit of one Sq. Mts.

#### **Item No. 41**

**Providing and fixing flush door shutters, solid core construction with frame of first class hardwood with cross board and face veneer or plywood face panels, including anodised aluminium butt hinges with necessary screws. (B) Non-decorative type and block board core anodised aluminium butt hinges in flush door shutters (2) 35 mm thick.**

#### **Materials**

Timber To be used shall be first class Teak wood as per IS:4021. Timber shall be of the best quality and well-seasoned by a suitable process before being planned to the required sizes. The maximum permissible moisture content shall be from 10 to 16 percent for timber 50mm and above in thickness and 8 to 14 percent of timber less than 50mm in thickness for different regions of the country as stipulated in IS:287. Timber shall be close grained, of uniform colour and free from decay, fungal growth, boxed heart, pitch pockets or streaks on the exposed edges, borer holes, splits and cracks.

Flush door shutters of the solid core type with plywood face panels shall conform to IS:2202 (Part 1) and with particle board/hard board face panels shall conform to IS:2202 (Part 2).

Transparent sheet glass shall conform to the requirements of IS:2835. Wired and figured glass shall be as per IS:5437.

Builder's hardware for fittings and fixtures shall be of the best quality from approved manufacturers.

#### **Workmanship**

The workmanship and finish of wood work in doors, windows, ventilators and partitions shall be of a very high order. Contractor shall ensure that work is executed in a professional manner by skilled carpenters for good appearance, efficient and smooth operation of the shutters.

All works shall be executed as per the detailed Drawings prepared by the Contractor and/or as directed by the client.

All members of the door, window, and ventilator shall be straight without any warp or bow and shall have smooth well planed faces. The right angle shall be checked from the inside surfaces of the respective

members of the frame. Frames shall have mortice and tenon joints which shall be treated with an approved adhesive and provided with metal or wood pins. The vertical members of the door frame shall project 50 mm below the finished floor level. The finished dimension of frames shall be rebated on the solid for keying with the plaster and for receiving the shutters. The depth of rebate for housing the shutter shall be 15 mm. The size of the frames shall be as specified in the respective items of work prepared by the Contractor. The workmanship shall generally conform to the requirements specified in IS:4021.

The face of the frames abutting the masonry or concrete shall be provided with a coat of coal tar.

Three hold fasts using 25 mm x 6 mm mild steel flats 225 mm long with split ends shall be fixed on each side of door and window frames, one at the centre and the other two at 300 mm from the top and bottom of the frame. For window and ventilator frames less than 1 m in height, two hold fasts on each side shall be fixed at quarter points.

Timber panelled shutters for doors, windows and ventilators shall be constructed in the form of framework of stiles and rails with panel insertion. The panels shall be fixed by either providing grooves in the stiles and rails or by beading. Glazing bars shall be as detailed in the Drawings prepared by the Contractor. The stiles and rails shall be joined by mortice and tenon joints at right angles. All members of the shutter shall be straight without any warp or bow and shall have smooth, well planed faces at right angles to each other. The right angle for the shutter shall be checked by measuring the diagonals and the difference shall not be more than  $\pm 3$  mm. Timber panels made from more than one piece shall be jointed with a continuous tongued and grooved joint, glued together and reinforced with metal dowels. The workmanship shall generally conform to the requirements specified in IS:1003 (Parts 1 & 2). The thickness of the shutter, width/thickness of the stiles/rails/panel type shall be as specified. Marine plywood panels conforming to IS:710 shall be used for doors where specified.

Details of the wooden flush door shutters, solid core type with specific requirement of the thickness, core, face panels, viewing glazed panel, venetian louvre opening, teak wood lipping etc. shall be as specified. Panels of shutter shall be of marine plywood conforming to IS:710. Flush door shutters shall be from reputed manufacturers and Contractor shall submit test results as per IS:4020, if so desired by the client.

Glazing of door, window, ventilator and partitions shall be with either flat transparent sheet glass, wired or figured glass. Transparent sheet glass shall be of 'B' quality as per IS:2835. The thickness and type of glazing to be provided shall be as specified.

The material of the fittings and fixtures either of chromium plated steel, cast brass, copper oxidised or anodised aluminum shall be as specified. The number, size and type of the fittings and fixtures shall be as specified.

Woodwork shall not be provided with the finishes of painting/varnishing etc. unless it has been approved by the client. The type of finish and the number of coats shall be as stipulated in the respective items of work prepared by the Contractor. Preparation of the wood surfaces and application of the finishes shall be in accordance with clause 7.32.

Wooden hand railing and architrave's shall be of the size and shape with the fixing arrangement as indicated in the Drawings prepared by the Contractor.

The framework of the partitions with mullions and transoms shall be with the sections of dimensions as specified. Panels of double/single glazing/plywood shall be fixed as per details specified. Partitions shall be fixed rigidly between the floor and structural columns/beams including provision of necessary shims for wedging etc. Finished work shall be of rigid construction, erected truly plumb to the lines and levels, at locations as per the construction Drawings prepared by the Contractor.

Any carpentry work which show defects due to inadequate seasoning of the timber or bad workmanship shall be removed and replaced by Contractor with work as per Specifications.

#### **Item No. 42**

**Providing and fixing 35 mm thick shutters for Doors, windows and clerestory windows including Indian teak wood frames 10 cm x 7 cm. size including anodized aluminium fixtures and fastenings including primer coat of approved quality and two coats of oil painting etc, complete. (i) Fully Glazed.**

**Materials:**

- (1) Wood for shutter shall conform to M-19
- (2) Glass shall conform to M-25
- (3) Anodized aluminum butt hinges shall conform to M- 28.

**Workmanship:**

The Description covers the requirement of preparation of shutters of doors, windows, clerestory windows their supply and fixing.

**Shutters**

Paneled shutters shall be constructed in the form of timber framework of styles and rails with panel inserted of type as specified in the detailed drawings. Panel shall be fixed by providing grooves in the style and rails. The styles and rails shall be joined to each other by mortise and tenon joints at right angles.

All members of the shutters shall be straight wrap or bow and shall have smooth, well planed faces at right angles to each other.

The size of styles and rails shall be as per drawings or as directed. Styles and rails of shutters shall be made of one piece only.

**Timbering paneling:**

Thickness of the panel shall be as specified in the Description as shown in the drawing or as directed. If the panel is made from more than one piece, the pieces shall be finished as shown in the detailed drawings and shall be joined with continuous groove with specified size. The end pieces of the panel and the top and bottom of the panel shall be provided with continuous lounge to frame into groove of the frame shutter. An air space of 1.5 mm shall be left in the groove of frame shutter while fixing the panels in it.

The faces of the panel as well as various pieces of the panel shall be closely fitted to the size of the grooves. Finishing of the corners of raised panel edges shall be done as shown in drawings or as directed.

**Fixtures & Fastening:**

The rate shall include anodized aluminum butt hinges including fixing with iron screws. The size and number of hinges shall be as per table given in drawing.

**Mode of measurements & payment:**

The rate for shutter includes cost of providing block and clear for keeping the shutter in open position as directed.

The dimensions of the shutter shall be measured clear size of the shutter in close position between the grooves of the frame.

The rate shall be for a unit of one Square meter.

**Item No. 43**

**Steel work welded in built up sections framed work including cutting ,hoisting, fixing in position and applying a priming coat of red lead paint (A) In beams and joists, channels angles Tees, flats , with connecting plates or angle cleats as in main and cross beams. Hip and jack rafters, purlins connects to common rafters and the like.**

**Materials**

The structured steel work shall conform to M-15. Red lead paint primer shall conform to I.S.: 102-1962.

**Workmanship**

The steel sections as specified or required shall be cut, square and to correct lengths, as per drawings and design. The cut ends exposed to view shall be finished smooth; No. two pieces shall be welded or other wise jointed to make up the required length of member, except as indicated in the drawing or as directed.

All straightening and shaping to form shall be done by application of pressure and not by hammering. Any bending or cutting shall be carried out in such a manner as not to impair the strength of the metal. All operations shall be done in cold state unless otherwise directed/permitted.

Welding shall generally be done by electric process. Gas welding shall be resorted to using oxyacetylene flame with specific approval. Gas welding shall not be permitted for structural steel work.

The work shall be done as shown in the shop drawings which should clearly indicate various details of the joints to be welded shop and site welds as well as type of electrodes to be used. Symbol for welding on plans and shop drawings shall be according to I.S. 813-1961. As far as possible every effort shall be made to limit the welding that must be done after improper welding that is likely to be done due to heights and difficult position on scaffoldings etc.

The welding work shall conform to I.S. 816-1969.

Preparation of surfaces: Surface which are to be welded together shall be free from loose mill scale rust paint grease or other foreign matter. A coating of boiled linseed oil shall be permitted.

Assembly of welding: Before welding is commenced, the plates shall first be brought together and firmly clamped or spot welded at specified distance. The temporary connection has to be strong enough to hold the plates accurately in place without displacement.

**Precautions :** All operations connected with welding and cutting equipment shall conform to safety requirement given in I.S. 818-1968.

The following points shall be borne in mind during the process of welding

(a) welds shall be made in flat position wherever practicable.

(b) Arc length, voltage and amperage shall be suited to the thickness of material, type of groove and other circumstances of the work.

(c) The segments of welding shall be such as to be considered harmful to the strength shall cut out and rewelded.

The defective welds which shall be considered harmful to the strength shall cut out and rewelded.

Finished welds and adjacent parts shall be protected with clean boiled linseed oil and after all stage has been removed welds and adjacent parts shall be painted after the same are approved.

All the members shall be thoroughly cleaned of rust scales, dust etc. and given a priming coat of red lead paint before fixing them in position.

#### **Mode of measurements & payments**

The steel work shall be measured in general as under.

(a) All work shall be measured on the basis of finished dimensions as fixed at site and measured net unless specified otherwise.

(b) The weight of steel sections, steel strips in finished work shall be calculated from standard weight on the same basis on which steel is supplied to the Contractor by department or those given in relevant I.S. if steel is arranged by the contractor.

(c) The weight of steel plates and strips shall be taken from relevant I.S. based on 7.85 Kg/sq. metre for every millimetre Sheet thickness if steel is supplied by the contractor, otherwise, the weight shall be calculated on the basis on which steel is supplied to the contractor by department.

(d) Unless otherwise specified weight of clearets, brackets, packing pieces, bolts, nuts, washers, distance pieces, separators, diaphragm gusset (taking over all square dimensions) fish plates etc. shall be added to the weight of respective items.

(e) In rivetted work allowance to be made of weight of rivet heads. No deductions shall be made for rivet or bolt holes excluding holes for anchor or holding down bolts.

(f) For forged steel and steel castings, weight shall be calculated on the basis of 7850 kg/cum.

(g) Unless otherwise specified an addition of 2.5 percent of the weight of structure shall be made for shop and site rivet heads in rivetted steel structure.

(h) Unless otherwise specified, no allowance shall be made for the weld metal in case of welded steel structure.

(i) Dimensions other than cross sections and thickness of plates shall be measured to nearest 0.001 m.

(j) Mill tolerance shall be ignored when weight is determined by calculation.

The rate includes cost of all material, labour, erection, hoisting, scaffolding protective measure, required for proper completion of the item of work. This shall also included conveyance and delivery handling, loading, unloading and storing etc. required for completing the item described above including necessary wastage involved.

The rate shall be for a unit of quintal

#### **Item No. 44**

**Providing and laying chequered terrazo tiles 28mm thick with marble chips of sizes upto 6mm in treads of stairs and staircases in 12mm thick bed of lime mortar 1:1.5 (1-Lime putty :1.5 coarse sand) or C.M. 1:6 (1- cement: 6- coarse sand) jointed with neat cement slurry mixed with pigment to match the shade of tiles including rubbing and polishing complete. (A) Light shades using white cement.**

#### **Materials :**

Water shall conform to M-1. White cement shall conform to M-3A. Cement mortar shall conform to M-7. Chequered tiles shall conform to M-31.

#### **Workmanship:**

##### **Laying:**

The work shall be carried out for skirting or dedo. Before fixing Chequered precast concrete terrazzo tiles of shade and size as specified, the surface shall be prepared by heavy scarping, making joints etc to the required line, level and plumb. The surface shall be thoroughly wetted before commencing the laying work. There after about 10 mm thick backing of cement mortar in specified proportion shall be applied on the surface in true line and level generally as per specifications of plaster item.

##### **Fixing:**

The back of each tile to be fixed shall be smeared with cement paste of matching colour and the mosaic tiles shall then be gently tapped against the surface with a wooden mallet. The skirting shall be done only after the flooring is completed. Any pipes coming out of the wall through the dedo or skirting shall only be at the inter section of the horizontal and vertical joints. The tiles shall not have staggered joints. The joints shall be true to entire line both ways and vertical joints shall be in line with joints or flooring. Tiles shall be fixed as close as possible to the adjoining tiles and any difference in the thickness of the mosaic tiles shall be evened out in the cement paste so that all the tiles faces are set in conformity with one another. The skirting shall project uniformly and not more than 6 mm thickness beyond the finished surface above. Top of skirting or dedo shall be truly horizontal. The risers of steps, skirting or dedo shall rest on top of treads of flooring. Wherever required the tiles shall be cut (sawn) and thin edges smoothed before use.

##### **Curing:**

Curing shall be done for 7 days continuously.

##### **Finishing:**

Skirting and dedo shall be hand polished to have an even smooth and shining surface. In case of skirting only 10 mm x 10 mm groove shall be provided at the junction of cement plaster and cement tiles.

##### **Mode of measurements and payment:**

The Chequered precast concrete terrazzo tiles with light shade using white cement base shall be paid under this item. The length shall be measured along finished surface of the riser, skirting or dedo, correct to a centimeter height measured from finished level of treads, or floor to the top (under side of treads in case of steps).

The rate shall include all Materials and labour required for all the operations involved and described above. The rate shall be for a unit of one sq. metre.

**Item No. 45**

**Providing and fixing window having extruded aluminium Colour anodized section frame main outer size 95mm x 24mm x 1.17mm @ wt.of 0.738 Kg./mt , horizontal Three track member size 92mm x 31.75mm x 1.30mm,@ Wt.1.07 Kg./mt , vertical member of size 92mm x 31.75mm x 1.50mm @ Wt. 1.06 Kg./mt with sliding shutters of horizontal member size 40 mmx18mm x1.29mm @ wt.of 0.456 Kg./mt, vertical member of size 40mm x 18mm x 1.29 mm @ wt.of 0.456Kg./mt/ with 5 mm thick transparent bronze colour tinted float glass with powder coated aluminium fittings and fixtures and transparent silicon sealant glass fixing to frame as per details etc**

Matt anodized aluminium sliding windows shall be made of extruded aluminium sections having thickness not less than specified in item and matt finished colour anodized not less than 20 micron.

The glass 5 mm thick float Saint/Gobain glass white or colour as directed.

At bottom drain section shall be used to drain out rain water. The drain track shall be three track 92 mm x 31.55 weighing not less than 1.070 Kg/mt. The end and side tracks shall not be weighing less than 0.933 Kg/meter and thickness shall not be less than 1.5 mm. The work shall be carried out as directed by Engineer-in-charge.

Shutter Frame Work :- The fully glazed shutter frame shall be made from top and bottom section weighing not less than 0.464 Kg/meter. having bearing of Durlin or Nylon 66. All the fixture, fastener bearing, locks, handle, gaskets shall be used after getting approved from Engineer-in-charge and architect. The handle section shall be weighing not less than 0.417 Kg/meter. The interlock section shall be weighing not less than 0.464 Kg/mt. and having thickness of 1.5 mm. The glass panel shall be fixed in frame work using EPDM gaskets.

The whole assembly of window shall be fixed in best workman like manner to have smooth operations. All the windows shall be sealed to the R.C.C. or brick work with silicon sealants of dow corning or Wacker Germany as approved by Engineer-in-charge or his consultant.

**Mode of Measurement & Payment :**

The rate shall be :

Providing & fixing Aluminium section window in marble frame with all fixtures & fastenings, applying painting etc complete for a unit of one Sq.mt

**Item No. 46**

**Providing and fixing M.S. grills of required pattern to wooden/Stone frames of windows etc. with M.S. flats at required spacings and frame around, square or round bars with round headed bolts and nuts or by screws (A) Plain Grill.**

**Materials :**

The structural steel shall conform to M-15.

**Workmanship :-**

The M.S. Grills shall be prepared as per the drawings or as directed for fixing to wooden frames of windows or on concrete /masonry face etc.

The grill shall be fabricated to the designs and pattern shown in the drawings and the weight shall be as directed, and the joints shall be reworked or welded as shown in the plan or as directed. The grill so formed shall be fixed into the strip frames of the windows etc. before they are erected in position. The outside strip frame of the grill shall be housed to its full thickness into the recess cut into the frame of the windows etc. The grill shall be fixed to the frame with number of bolts and nuts or screws viz. bolt nut/screw per 30 cm. of the length of outer strip subject to a minimum of 2 Nos. on such side of the frame or as indicated in the drawing or as directed.

The bolts and nuts or screws shall be counter sunk and shall be fixed with the top of their heads flush with the face of the frame strips.

**Mode Of Measurement And Payment :-**

Payment shall be made for weight of screws, bolts and nuts etc. only weight of grill shall be paid.  
The rate shall be for a unit one Kg.

**Item No. 47**

**Providing and fixing rolling shutters of approved make made of 80 mm wide M.S. laths inter-locked together through their entire length and jointed together at the ends by end locks mounted on specially designed pipe shaft with bracket plates, guide channels and arrangements for inside and outside locking with push-pull operation including the cost of hood cover and spring etc. complete. (B) Shutters having width 3.5 M. and above**

**Materials:**

The rolling shutter shall conform to material section - M-22.

**Workmanship:**

Brackets shall be fixed on the lintel or under the lintel as specified with raw, plugs, & screws, bolts etc. The shaft along with the spring shaft than be fixed on the brackets.

The lath portion (shutter) shall be laid on ground and the side guide channels shall be bound with ropes etc.

The shutter shall then be placed in position & top fixed with pipe shaft with bolts & nuts.

The side guide channels & cover frames shall then be fixed to the walls through the plate welded to the guides.

These plates & bracket shall be fixed by means of steel screws, bolts & raw plugs concealed in plaster to make their location invisible. Fixing shall be done accurately in workmen like manner that the operation of the shutter is easy & smooth.

The shutters shall be single or double leaf shutters as specified. The guide rails shall be sufficiently long and continued along the wall on both ends so that the sliding can rest against walls, living full opening when required.

The guide rails shall be fixed to the floor by means of anchor bolts embedded in the cement concrete floor. The steel section at the top shall be suitably supported from the walls. Two channel sections shall be suitably fixed vertically below the extreme clamps in the wall and floor to avoid the shutters from going out of the support at the top and bottom. A suitable clamping arrangement will be provided at either end of the opening to avoid the shutters from rolling back into opening.

All the adjoining work damaged while fixing shall be made good to match the existing work.

All members of the sliding shutter including T-iron shall be thoroughly cleaned of rust, scales, dust etc. and give a priming coat of red lead before fixing them in position.

**Mode of measurements & payments**

Clear width & clear height of the opening for the rolling shutter shall be measured correct to mm. The clear distance between the seal & soffit (bottom of lintel) of the opening shall be the clear height.

The area shall be calculated in Square meter Correct to two places of decimal.

The sliding doors shall be measured in sq. meter. The height of the shutters shall be measured from outside to cut of the guide rail and width outside to outside of shutters including vertical channels in side. The rate includes providing handles stoppers and locking arrangement etc. complete. The rate shall include the cost of materials & labour involved in all the operation describe above including cost of top cover & spring ball bearing & mechanical device of chain & crank operation.

The rate shall be for unit of **one sq. meter.**

**Item No. 48**

**Providing and fixing standard extruded of aluminium section of size 63mm x 38.10mm x 1.2mm @ Wt. 0.643 Kg./mt with colour anodized aluminium frame for ventilation with 5 mm thick frosted glass as details etc complete for Ventilation**

Matt anodized aluminum sliding windows shall be made of extruded aluminum sections having thickness not less than specified in item and matt finished colour powder coated of not less than 200 microns or as directed by EIC. The glass 5 mm thick float Saint/Gobain glass white or colour as mentioned in BOQ or as directed by EIC.

At bottom drain section shall be used to drain out rain water. The drain track shall be three track 92 mm x 31.55 weighing not less than 1.070 Kg/mt. The and side track s shall not be weighing less than 0.933 Kg/meter and thickness shall not be less than 1.5 mm. The work shall be carried out as directed by Engineer-in-charge.

Shutter Frame Work:- The fully glazed shutter frame shall be made from top and bottom section weighing not less than 0.464 Kg/meter having bearing of Durlin or Nylon 66. All the fixture, fastener bearing, locks, handle, gaskets should be used after getting approved from Engineer-in-charge and architect. The handle section shall be weighing not less than 0.417 Kg/meter. The interlock section shall be weighing not less than 0.464 Kg/mt. and having thickness of 1.5 mm. The glass panel shall be fixed in frame work using EPDM gaskets.

The whole assembly of window shall be fixed in best workman like manner to have smooth operations. All the windows shall be sealed to the R.C.C. or brick work with silicon sealants of Dow corning or Wacker Germany as approved by Engineer-in-charge or his consultant.

**Mode Of Measurement & Payment:**

The rate shall be for complete work of providing & fixing Aluminum section window in marble frame with all fixtures & fastenings, applying painting etc complete for a unit of one Sq.mt

**Item No. 49**

**Providing corrugated G.I. sheet of class-3 roofing fixed with glavanished iron J or L Hooks, Bolts and nuts 8mm diameter with bitumen and G.I. limpet washer or G.I. limpet washer. filled with white lead complete excluding the cost of purlins, Rafters and Trusses.(1) 0.80 mm thick sheet.**

**Materials:****Roofing/ Clading Material:**

Type of Roofing Material: Colour Coated G.S. sheet roffing

Outside Colour coating / Inside Colour coating: As per availability/Ivory

**Laying of sheets:**

The sheets shall be laid in to a true plane with the line of corrugations truly parallel or normal to the sides of area to be covered. The sheets shall not generally be built into gables and parapets. They shall be bent up along their side edges close to the wall, and the junction shall be protected by suitable flushing or by projecting drip course.

The laps at end shall be provided as per manufacture guideline.

The sheets shall be cut to the dimensions or the shape of the roof either along their lengths or their width or in slant across the line of corrugations at hips and valleys. The sheets shall be cut carefully with a straight edge and chisel to give straight finish. The sheets shall be laid such that the laps are turned away from the usual direction of local heavy rain.

**Fixing of sheets:**

Sheets shall be fixed to the other roof members such as hips or valley rafter etc. with necessary fitting, accessories.



**Mode of measurements and payment**

The measurements of the sheet roof shall be taken for finished work in superficial area in general plane (not girthed on the roof). The laps between the Sheets both at their ends and along the side edges shall not be measured. The overlaps of sheets over the valley piece and their under lap under the ridge, hip and flashing piece shall be included in the measurements.

No deductions in measurements shall be made for openings for chimney stacks, sky light, turbo ventilator etc., of area up to 0.40 sq. mt. nor extra be paid for labour in cutting and for wastage etc. in forming such openings.

The rate of roof shall include the cost of all materials and labour involved in all operations described above. The rate also includes the cost of provision, erection and removal of the scaffolding, benching, ladders, templates and tools required for the proper execution and erection of the work. The rate includes the cost of accessories.

**The rate shall be for a unit of one sq. meter Accessories:**

- i) Hangers to be fixed based on area to support Cables & Light fixtures
- ii) Skylights to be fixed based on area and as per design and drawing
- iii) Turbo-ventilators to be fixed based on area & no. of air rotations as per design and drawing.

**General notes.**

- 1) Design of structure should strictly comply.
- 2) The end wall tie beams on one side of the building should be kept open for entry of equipment's for erection for roofing. The final plan for erection should be discussed with the engineer in charge.
- 3) Installation will be undertaken only after successful completion of Entire proposed Site at curing to the support structure. Installation will be done only after 15 days of curing to the last casted beam.
- 4) Roofing Installation shall not be carried out in the event of wind velocity above 20 Km/hr.
- 5) Minor colour peeling / chipping / scratching can happen due to Onsite Fabrication & Erection. The same will be rectified by applying Epoxy lacquer.
- 6) Proper storage of Coils on Plastic/Wooden Pellets under covered conditions with clean atmosphere away from dust & water. Unloading of coils to be strictly made by Hydra / Crane. Mishandling of coil can damage its shape and change the Inner Diameter. Any damage to coil during unloading will be sole responsibility of the Contractor.

**Item No. 50**

**Providing and fixing 150mm wide 450mm over all semicircular plain G.I. sheet class-3 gutter with Iron brackets 40mm x 3mm size Bolts, Nuts, washers etc. including making necessary connection with rain water pipes. (i) 0.80 mm thick Sheet.**

**Materials:**

These shall be of plain galvanised sheets Class -3 of 0.80 mm. thickness. The gutter shall be designed to carry the maximum discharge from the roof without flowing over and shall be constructed wherever possible with shank channel or gutter.

**Workmanship :**

The longitudinal edges, shall be turned back to the extent of 12 mm. and beaten to form a rounded edge. The ends of the sheets at junction of pieces shall be hooked into each other and beaten flush to avoid leakages.

The size of gutters shall be as specified in the item.

The gutter shall be laid with a minimum fall 1 in 120 Gutter shall be true to line and slope and shall be supported on fixed M.S. Flat iron brackets bent to shape or any other suitable bracket.

**Mode of measurements & payment:**

The measurements of gutters shall be taken for finished work in length along their centre lines. No laps shall be measured.

The rate of gutter shall include the cost of all labour and materials specified above, including all specials such as angles, junctions, drop ends or funnel shaped connecting pieces, step ends etc. flat iron brackets and bolts and nuts required for fixing the latter to the roof members.

The rate shall be for a unit of one running metre.

**Item No. 51**

**Painting two coats (excluding priming coat) on new steel and other metal surface with enamel paint, brushing, interior to give an even shade including cleaning the surface an even shade including cleanicn the surface of all dirt, dust and other foreign matter.**

**Materials**

Red-oxide – zinc chrome primer shall conform to IS:2074.

Synthetic enamel paint shall conform to IS : 2932.

Aluminum paint shall conform to IS:2339.

All the materials shall be of the best quality from an approved manufacturer. Contractor shall obtain prior approval of the client for the brand of manufacture and the colour/shade. All the materials shall be brought to the site in sealed containers.

**Workmanship**

Painting work shall be carried out only on thoroughly dry surfaces. Painting shall be applied either by brushing or by spraying. Contractor shall procure the appropriate quality of paint for this purpose as recommended by the manufacturer. The workmanship shall generally conform to the requirement of IS:1477 (Part 2).

The type of paint, number of coats etc. shall be as specified in the respective items of work.

Primer and finish paint shall be compatible with each other to avoid cracking and wrinkling. Primer and finish paint shall be from the same manufacturer.

All the surfaces shall be thoroughly cleaned of oil, grease, dirt, rust and scale. The methods to be adopted using solvents, wire brushing, power tool cleaning etc., shall be as per IS:1477 (Part – I) and as indicated in the item of work.

It is essential to ensure that immediately after preparation of the surfaces, the first coat of red oxide-zinc chrome primer shall be applied by brushing and working it well to ensure a continuous film without holidays. After the first coat becomes hard dry, a second coat of primer shall be applied by brushing to obtain a film free from `holidays.

After the second coat of primer is hard dry, the entire surface shall be wet rubbed cutting down to a smooth uniform surface. When the surface becomes dry, the undercoat of synthetic enamel paint of optimum thickness shall be applied by brushing with minimum of brush marks. The coat shall be allowed to hard-dry. The under coat shall then be wet rubbed cutting down to a smooth finish, taking adequate care to ensure that at no place the undercoat is completely removed. The surface shall then be allowed to dry.

The first finishing coat of paint shall be applied by brushing and allowed to hard-dry. The gloss from the entire surface shall then be gently removed and the surface dusted off. The second finishing coat shall then be applied by brushing.

At least 24 hours shall elapse between the application of successive coats. Each coat shall vary slightly in shade and this shall be got approved by the client.

**Item No. 52**

**Providing & fixing UV stabilised fiberglass reinforced plastic sheet, including fixing with polymer coated 'J' or 'L' hooks, bolts & nuts 8mm dia. G.I plain/bitumen washers complete but excluding the cost of purlins, rafters, trusses etc. The sheets shall be manufactured out of 2400 TEX panel rovigs incorporating minimum 0.3% ultra-violet stabiliser in resin system under approximately 2400 psi and hot cured. They shall be of uniform pigmentation and thickness without air pockets and shall conform to IS 10192 and IS 12866. The sheets shall be opaque or translucent, clear or pigmented, textured or smooth as specified.**

**Materials:**

**Roofing/ Cladding Material:**

Type of Roofing Material: UV stabilized fiberglass reinforced plastic sheet 2 mm thick.

Colour: Clear

**Laying of sheets:**

The sheets shall be laid in to a true plane with the line of corrugations truly parallel or normal to the sides of area to be covered. The sheets shall not generally be built into gables and parapets. They shall be bent up along their side edges close to the wall, and the junction shall be protected by suitable flushing or by projecting drip course.

The laps at end shall be provided as per manufacture guideline.

The sheets shall be cut to the dimensions or the shape of the roof either along their lengths or their width or in slant across the line of corrugations at hips and valleys. The sheets shall be cut carefully with a straight edge and chisel to give straight finish. The sheets shall be laid such that the laps are turned away from the usual direction of local heavy rain.

**Fixing of sheets:**

Sheets shall be fixed to the other roof members such as hips or valley rafter etc. with necessary fitting, accessories.

**Mode of measurements and payment**

The measurements of the sheet roof shall be taken for finished work in superficial area in general plane (not girthed on the roof). The laps between the Sheets both at their ends and along the side edges shall not be measured. The overlaps of sheets over the valley piece and their under lap under the ridge, hip and flashing piece shall be included in the measurements.

No deductions in measurements shall be made for openings for chimney stacks, sky light, turbo ventilator etc., of area up to 0.40 sq. mt. nor extra be paid for labour in cutting and for wastage etc. in forming such openings.

The rate of roof shall include the cost of all materials and labour involved in all operations described above. The rate also includes the cost of provision, erection and removal of the scaffolding, benching, ladders, templates and tools required for the proper execution and erection of the work. The rate includes the cost of accessories.

**The rate shall be for a unit of one sq. meter Accessories:**

- i) Hangers to be fixed based on area to support Cables & Light fixtures
- ii) Skylights to be fixed based on area and as per design and drawing

**General notes.**

- 1) Design of structure should strictly comply.
- 2) The end wall tie beams on one side of the building should be kept open for entry of equipment's for erection for roofing. The final plan for erection should be discussed with the engineer in charge.
- 3) Installation will be undertaken only after successful completion of Entire proposed Site at curing to the support structure. Installation will be done only after 15 days of curing to the last casted beam.
- 4) Roofing Installation shall not be carried out in the event of wind velocity above 20 Km/hr.
- 5) Minor colour peeling / chipping / scratching can happen due to Onsite Fabrication & Erection. The same

will be rectified by applying Epoxy lacquer.

- 6) Proper storage of Coils on Plastic/Wooden Pellets under covered conditions with clean atmosphere away from dust & water. Unloading of coils to be strictly made by Hydra / Crane. Mishandling of coil can damage its shape and change the Inner Diameter. Any damage to coil during unloading will be sole responsibility of the Contractor.

### Item No. 53

**Providing and fixing of Self Supported Structure Less PROFLEX or Equivalent Roofing systems with proper overlapping and seaming b/w different sheets without making holes or preventing the overturning the roof by wind addition made up from superior quality, structural grade steel. Base metal width 912 mm, Steel Grade : Grade D and Thickness 0.80 mm BMT, 0.85 mm APT with tolerance of +/- 0.04 mm, Regular Modified Polyester Imported Colour Coated Galvalume Steel having Profiled width of 625 mm +/-10mm. Design, supply, & fabrication of self supported single span arch roof fabricated from mechanically seamed manufactured by American Machines to profiles of Imported Galvalume Cold Rolled Structural Steel coils as per standard ASTM A792, Steel Sheet, Aluminium-Zinc Alloy Coated by Hot-Dip Process. The work should be carried out by specialize and approved agency only. The rate of item is including fitting as per standard specification.**

#### **Scope**

This work shall consist of providing roof material as per specifications, designing of self-supporting roof system, profiling, lifting of the material to desired height by suitable means like Hydra/ Crane of required capacity and fixing etc. complete as per the drawings or as directed by the Engineer-in-Charge.

#### **Materials & Physical Requirements:**

**Base Steel :-** Sheet steel shall manufacture from 1.50 mm based metal thickness with minimum 350 MPa Yield Strength. The steel manufacture test certificate for chemical composition and mechanical properties of steel must be produced to the authority prior to installation.

**Metallic Coating:-** Sheet shall have a hot dip metallic Aluminum –Zinc alloy Coating (55 %) and Zinc (45%) with total mass coating of 150 Gms/sqm.

**Colour Coating:-**The top surface of sheet shall have coating thickness 20 microns (minimum) and bottom surface of sheet 12 microns (minimum).

**Profile:-**Profile shall be made from the coil sheet width of range 900 mm to 920 mm and manufacture into profile having effective Profile width of 610 mm to 625 mm and effective depth profile sheet ranges from 195 mm to 210 mm (from top of edge of inter- locking to bottom of sheet).The profile shall be rolled at site in single length from ridge to eave without any end lap or as approved by concern authority.

#### **Erection and Fixing:-**

a) The installation shall be done in accordance to the standard practice as specified by the manufacturer and approved by the concern authority. All sheet and accessories must be stored and finally erected without any damaged.

b) Single length shall be installed from ridge to eave (on site roll forming).

c) The contractor shall be submit methodology for fixing and also a maintenance manual for routine maintenance.

d) Flashing, capping and trim shall be manufacture from the in the length as per manufacture recommendation .The shape and girths shall be as per design requirement and shall be approved by the concern authority.

e)The contractor shall ensure that panel erector is familiarized with the erection procedure and all the supporting member are straight, level and true, before starting the panel erection .The panel shall be erected according to approved shop drawings by the concern authorities.

#### **1.3 Table: 1 Materials & Physical Requirements:**

Sr. No.	Materials	Requirements
1.	BASE METAL	COLD ROLLED STRUCTURAL QUALITY STEEL IN COIL FORM COIL WIDTH : 900 mm to 920 mm
2.	STEEL GRADE	GRADE D: 350 MPaYSt. Min.
3.	STEEL THICKNESS	1.50 mm (Base Metal Thickness)
4.	BARE GALVALUME COATING	AZ 150, 150 Gms./Sq. M. Alu-Zinc Coating (55% Al. &45% Zn.)
5.	COLOUR COATING & TESTING METHODS	R.M.P., S.M.P., H.D.P. & P.V.D.F. COATINGS Top Side – Suitable for Roll - For Taming, 20 microns total dry thickness, polyester on primer, NCCA II – 1 or ECCA T4 pencil hardness HB – 2H. NCCA Standard T-Bend Test method or ASTM D4 145-83 (no pick-off with scotch #610 tape). ECCA Test to 0.5T is also acceptable. Coating Test to ECCA T1 at every coil. Back Side – 12 microns total dry thickness, epoxy primer and polyester wash-coat.
6.	STANDARD	ASTM A792, Steel Sheet, Aluminum-Zinc Alloy Coated by Hot-Dip Process.

#### Mode of measurements and payment

The measurements of the sheet roof shall be taken for finished work in superficial area in general plane (not girthed on the roof). The laps between the Sheets both at their ends and along the side edges shall not be measured. The overlaps of sheets over the valley piece and their under lap under the ridge, hip and flashing piece shall be included in the measurements.

No deductions in measurements shall be made for openings for chimney stacks, sky light, turbo ventilator etc., of area up to 0.40 sq. mt. nor extra be paid for labour in cutting and for wastage etc. in forming such openings.

The rate of roof shall include the cost of all materials and labour involved in all operations described above. The rate also includes the cost of provision, erection and removal of the scaffolding, benching, ladders, templates and tools required for the proper execution and erection of the work. The rate includes the cost of accessories.

#### The rate shall for a unit of one complete job/No.

##### Accessories:

- i) Hangers to be fixed based on area to support Cables & Light fixtures
- ii) Skylights to be fixed based on area and as per design and drawing

##### General notes.

- 1) Design of structure should strictly comply.
- 2) The end wall tie beams on one side of the building should be kept open for entry of equipment's for erection for roofing. The final plan for erection should be discussed with the engineer in charge.
- 3) Installation will be undertaken only after successful completion of Entire proposed Site at curing to the support structure. Installation will be done only after 15 days of curing to the last casted beam.
- 4) Roofing Installation shall not be carried out in the event of wind velocity above 20 Km/hr.
- 5) Minor colour peeling / chipping / scratching can happen due to Onsite Fabrication & Etraction. The same will be rectified by applying Epoxy lacquer.
- 6) Proper storage of Coils on Plastic/Wooden Pellets under covered conditions with clean atmosphere away from dust & water. Unloading of coils to be strictly made by Hydra / Crane. Mishandling of coil can damage its shape and change the Inner Diameter. Any damage to coil during unloading will be sole responsibility of the Contractor.

#### Item No. 54

**Providing and fixing of modules of 3 no of 24" dia Wind operated Aluminium Advanced type Turbo ventilators with single Transparent Skylight Sheet of 2ft width and 21ft length at interval of 10th panels in Self Supported Proflex Roofing Systems on centre as per manufacturers specifications**

Turbo-ventilators to be fixed based on area & no. of air rotations as per design and drawing.

Item shall be executed as per instruction of engineer in charge. Turbo Ventilator shall be approved by engineer in charge before procurement.

Effective total dia – 24", ventilator outer dia - 30", overall height - 19"

Inner arms - M.S. with electro zinc plating

Outer Arms - M.S. with electro zinc plating

Frp base plate - 2 mm thick clear 1.020 mtr wide and 1.65 mtr long matching sheet profile. Weight 8 kg (Approx)

The rate shall be for a unit of number.

#### **Item No. 55**

**Providing and fixing full height Plan/colour PVC partition system 50mm thick consisting of 40mm sandwich PVC panel made out of 36mm high density expanded polystyrene sheet (E.P.S. Thermocol) stuck on both side with 2mm thick plain PVC sheet reinforced with frame work made from 35mm x 5mm M.S. angle. In between two M.S. angles 4 mm thick plan heat moulded PVC 'C' channel of size 50mm x 100 mm with feathered edges shall be fixed on floor and 50 x 75 mm with feathered edges plain/printed/prelim PVC 'C' channel shall be fixed in the ceiling. Sandwich PVC panel shall be inserted in the PVC "c" channel. The first and last M.S. angle should be erected such that it is inside a PVC C channel of size 50 x 75mm. In between adjoining EPS sandwiched PVC partition panel 4mm thick x 75mm width plain PVC sheet feathered at edges shall be stuck on front and back face using solvent cement etc. And additional 4mm thick PVC strip of 40mm width is to be stuck on the interior side of the C channel using PVC solvent adhesive complete as per direction of Engineer in charge, manufacture's specification and drawing.**

#### **Scope of work:**

The item consists of providing and fixing full ht. Partition complete on site and as directed by Engineer in charge. The framing should be installed up to R.C.C. Slab / Beam. Wooden Bidding to be provided for filling the uneven gap finished with paint.

#### **Material and workmanship:**

The sandwich panel shall be made of 36 mm thick high density expanded polystyrene sheet (E.P.S. Thermocol) stuck on both side with 2mm thick plain PVC sheet reinforced with frame work made from 35mm x 5mm M.S. angle.

In between two M.S. angles 4 mm thick plan heat moulded PVC 'C' channel of size 50mm x 100 mm with feathered edges shall be fixed on floor and 50 x 75 mm with feathered edges plain/printed/prelim PVC 'C' channel shall be fixed in the ceiling.

The first and last M.S. angle should be erected such that it is inside a PVC C channel of size 50 x 75mm.

In between adjoining EPS sandwiched PVC partition panel 4mm thick x 75mm width plain PVC sheet feathered at edges shall be stuck on front and back face using solvent cement etc. And additional 4mm thick PVC strip of 40mm width is to be stuck on the interior side of the C channel using PVC solvent adhesive complete

Partition shall accurate in plumb line with suitable fixing on floor, wall & R.C.C. slab/beam. Even groove should be maintained throughout. The entire work shall be as per direction of Engineer in charge, manufacture's specification and drawing.

**Mode of measurement & Payments:**

The payment shall be made on Sq. Mtr. (Length x Visible Height) of finished work. Rate shall be included the cost of materials, labours and transportation. To complete the items as per instruction of Engineer in-charge. The rate shall be paid for a unit of one sq. Mtr.

**Item No. 56**

**Providing and fixing Kitchen sink with C.I. or M.S. brackets, painted white including cutting holes in walls and making good the same but excluding fittings. (C) Vitreous China Sink.(i) 600mm x 450mm x 150mm size**

**Materials**

White glazed vitreous china sink 600 mm. x 450 mm. x 150 mm. size shall conform to M-39.

**Workmanship**

The kitchen sink shall be supported on a pair of M.S. or C.I. brackets fixed in cement mortar 1:3 (1 cement : 3 coarse sand). The M.S. or C.I. brackets shall conform to I.S. 775-1962. The wall plaster on the rear shall be cut to rest over the top edge of the sink. After fixing the sink, plaster shall be made good and the surface finished to match with the existing one.

The C.P. brass trap and union shall be connected to 32 mm. nominal bore galvanised mild steel waste pipe which shall be suitably bent towards the wall and which shall discharge into an open drain leading to gully-trap or direct into the gully-trap on the ground on floor and shall be connected to a waste pipe through a floor trap on the upper floors. C.P. brass trap and union may not be provided where surface drain or a floor trap is placed directly under the sink and the waste is discharged to it vertically.

The height of front edge of the wash basin from the floor, level shall be 80 cms.

**Mode of measurements & payment**

The rate includes cost of all labour, materials, tools and plant and other equipment required for satisfactory completion of this item as described in workmanship.

The rate shall be for a unit of One number.

**Item No. 57**

**Providing and fixing with down water closet (European type, W.C. Pan) with integral P or S trap including jointing the trap with soil pipe in Cement Mortar 1:1 (1-Cement : 1-fine sand) (Seal and cover to be measured and paid for separately)(A) vitreous China Pattern :(i) in white colour**

**Materials:**

Wash down water closet (European type WC pan) shall conform to M-38 Cement mortar shall conform to M-7.

**Workmanship:**

Closet shall be fixed to the floor by means of 75 mm long 0.5 mm dia. Center sunk bolts and nuts embedded in the floor concrete using rubber or fiber washers so as not to allow any lateral displacement. The joint between the trap of WC and soil pipe shall be made with CM 1:1 (1 cement: 1 fine sand)

**Mode of measurements & payment:**

The rate shall include the cost of all labour for fixing pans and seat and cover, inlet, connections, etc. complete including testing the same.

The payment of seat and cover shall be made separately.

The rate shall be for a unit of one number.

**Item No. 58**



**Providing and fixing plastic seat and cover for wash down water closer with C.P. brass hinges and rubber buffers. (B) Black plastic seal and cover.**

The work shall be carried out as per direction of Engineer in charge

**Item No. 59**

**Providing and fixing chromium plated brass half turn flush cock of approved quality including fixing in pipe line etc. complete.(ii) 25mm dia.**

**Materials:**

Chromium plated brass half turn flush cock shall conform to M-42.

**Workmanship:**

The half turn flush cock of specified diameter shall be fixed as directed. The flush cock shall be fixed in G.I. pipe line with necessary fittings. The joints shall be made leak proof by using spun yarn and white zinc. The fixing work shall be carried out as per relevant specifications.

**Mode of measurements and payment:**

The rate includes cost of all materials and labour required for satisfactory completion of this Description including fittings.

The rate shall be for a unit of one number.

**Item No. 60**

**Providing and fixing washbasin with single hole for pillar tap with C.I. or M.S. brackets painted white including cutting holes and making good the same but excluding fittings.(A) Vitreous China:(ii) Flat Back washbasin 550 mm x v 400mm size. (i) In white colour.**

**Materials**

The White glazed earth ware washbasin shall be 550 cm x 400 mm of 1st quality and making as approved by the Engineer-in-charge. The wash basin shall conform to M-37.

**Workmanship**

The washbasin shall be fixed on the wall as and where directed. The washbasin shall be supported on a pair of M.S. or C.I. Brackets fixed in C.M.1: 3 (1 cement: 3 sand) the bracket shall conform to IS.775-1962. The wall plaster on the rear shall be cut to rest the top edge of the washbasin. After fixing the basin plaster shall be made good and surface finished matching with the existing one.

The bracket shall be painted white with ready mixed paint.

The C.I. brass trap and union shall be connected to 32 mm dia waste pipe which shall be suitably bent towards the wall and which shall discharge into an open drain leading to a gully trap or direct into the gully trap on the ground floor and shall be connected to a waste pipe through a floor trap on the upper floors. C.P. brass trap and union may not be provided where the surface drain or a floor trap is placed directly under the basin and the waste is discharged into vertically.

The height of the front edge of the washbasin from the floor level shall be 80cms.

The necessary inlet, outlet connections and fittings such as pillar cocks. C.P. dress trap waste trap waste pipe, stopcock, chain with rubber plug etc. shall be fixed.

The payment of fittings shall be made separately under separate Description.

**Item No. 61**

**Providing and fixing C.P. brass waste for washbasin or sink. (A) 32mmdia.**

**Materials:**

The C.P. brass waste trap and unions shall be of 32 mm dia and of best quality and make as approved by the Engineer in charge.



**Workmanship**

C.P. brass waste trap and union shall be connected to 32 mm dia. Waste pipe which shall be suitably bend towards the wall and which shall discharge into drain through a floor trap. The C.P. brass waste trap shall be provided for wash basin or sink as the case may be.

**Mode of measurements and payment**

The rate includes all labours and providing C.P. Brass waste trap and union including waste coupling of 32 mm dia. The rate excludes the cost of waste pipe of 32 mm dia.

The rate shall be for a unit of one number.

**Item No. 62****Providing and fixing M.I. fisher union for washbasin or sink. (A) 32mm dia.****Materials**

The 32 mm dia M.I. fisher union shall be of best quality and make as approved by the Engineer in charge.

**Workmanship:**

The 32 mm dia M.I. fisher union shall be fixed to wash basin or sink in best workman like manner.

**Mode of measurements & payment**

The rate includes all labours and materials, tools and plants, etc. required for satisfactory completion of the Description.

The rate shall be for a unit of one number

**Item No. 63****Providing and fixing screw down bib taps of following size.(A) Brass screw down bib tap polished bright. (i) 15mm dia.****Materials**

15 mm dia. Brass screw down with bright polished finish shall conform to IS 781 1977. The bib cock shall be best Indian make and quality.

**Workmanship**

The screw down bib cock 15 mm dia as specified above shall be fixed as directed. The threaded portion shall be smeared with white or red lead and around with a few turns of fine spun yarn round the screwed end of the pipe. The bib cock shall be than screwed and fixed to water tight position.

**Mode of measurements and payment**

The rate shall include cost of all labour, materials, tools and plant, etc. required for satisfactory completion of this Description.

The rate shall be for a unit of one number.

**Item No. 64****Providing and fixing pillar tap, capstan head, screw down high pressure with screws, shanks and back nuts. (i) 15mm dia.****Materials:**

The capstan head pillar tap of specified dia of C.P. over brass shall be of best quality and shall conform to IS 1975-1961. The pillar taps shall be of tested quality.

**Workmanship:**

The capstan head pillar trap of specified dia shall be fixed as directed with required washer of selected leather or rubber asbestos composition or of plastic as directed. The cock shall fix with pipeline with white zinc end spun yarn to make joint water tight. The work shall be carried out in best workman like manner.

**Mode of measurements and payment:**

The rate includes cost of all labour, materials tolls and plant, etc. required for satisfactory completion of this Description.

The rate shall be for a unit of one number.

**Item No. 65**

**Providing and fixing Urinal of approved quality including connection with trap and with integral longitudinal flush pipe.(A) Squating plate pattern white earthenware 550mm x 300mm.**

**Materials**

The white earthen ware flat pack or corner type urinal of size 430 mm x 260 mm x 350 mm shall conform to M-40.

**Workmanship**

The urinals shall be fixed in position by using wooden plugs and screws and shall be at a height 65 cms from the floor level to the top of the lip or urinal, unless otherwise directed. The wooden plugs shall be 50 mm x 50 mm at base tapering to 38 mm x 38 mm at top and 50 mm in length shall be fixed in wall in cement mortar 1:3 (1 cement:3 coarse sand). The urinal shall be connected to 32 mm dia galvanized mild steel waste pipe, which shall discharge in the channel or floor trap.

The connection between the urinal and flush or waste pipe shall be made by means of putty or white clad mixed with chopped hemp.

**Mode of measurements and payment**

The rate includes cost of all labours, materials, tools and plants, etc. required for satisfactory completion of this Description.

The rate shall be for a unit of one number.

**Item No 66**

**Providing and fixing PVC SWR Nahni trap IS 14735 for drain - 100 mm diameter with jali of the following nominal diameter of self cleansing design with C.I sread down or hinged grating including the cost of cutting and making good the walls.**

**Materials**

The cast iron (spun) Nahni trap shall be conforms to M-44. The C.I. hinged of screwed down cover shall be of best quality.

**Workmanship**

The Nahni trap with 100 mm dia inlet and 50 mm dia outlet shall be fixed as per drawing or as directed.

The Nahani trap shall be jointed with C.I. pipe 75 mm dia, with lead joints. The lead joints shall be done in conformation with IS 782 1976.

**Mode of measurements and Payment**

The rate includes cost of all labour, materials, tools and plants, etc. required for satisfactory completion of this description including lead jointing and testing.

The rate shall be for a unit of one number.

**Item No. 67 & 68**

**Providing laying and jointing in true line and level 15mm dia. and 25mm dia. U.P.V.C. Pipe (SCH- 40) for cold water including fittings as approved by Engineer In Charge. Pipe shall be fixed on the wall with the help of clamp at every two metre C/C or shall be concealed as directed including necessary fittings etc. including testing of pipe and joints and fixing the same with adhesive solvent, including cost of all materials.**

**Materials :-**

UPVC pipes mild steel tube of specified dia nominal bore and fittings shall conform to relevant I.S. code. UPVC pipes and fitting shall conform to M-43A.

**Workmanship:**

The U.P.V.C. Pipes of specified diameter shall be fixed as directed. Due to thermal expansion of rigid U.P. V. C. Pipes, due allowance shall be made particularly in over ground pipe lines for any change in length of pipe line which may occur during, installation or when pipe line is in service.

Above ground installation of rigid U.P.V.C. pipe should be undertaken after preparations are observed for their protection

against direct sun rays and mechanical damage.

The rigid U.P.V.C. pipe lines should not be kept exposed above ground when it passes through public places, railway lines, road side and footpaths.

U.P.V.C. pipes shall be supported at the following intervals: 20 mm dia. 500 mm, 25 mm. dia. 750 mm, 32 mm. dia. 900 mm.

Closer support spacings shall be provided if recommended by the manufacturer.

The guide lines indicated by the manufacturer regarding, handling, transportation, storing laying and jointing of pipes shall be kept in view during execution.

U.P.V.C. pipes shall be fixed on wall with wooden plugs and suitable plastic clamps.

**Jointing the pipes :**

The pipes and sockets shall be accurately cut. The ends of the pipes and fittings should be absolutely free from dirt and dust. The outside surface of the pipes and the inside of the fittings shall then be roughened with emery paper, and then solvent cement joint. Since solvent cement is aggressive to U.P.V.C., care must be taken to avoid applying excessive cement to the inside of pipe sockets as any surplus cement cannot be wiped off after jointing.

Empty solvent cement tins, brushes rags, or paper impregnated with cement should not be buried in the trenches. They should be gathered, not left scattered about, as they can prove to be a hazard to animals, which may chew them.

If manufacturer recommends its own methods of jointing, the same shall be adopted after necessary approval from the Engineer- in-charge.

**Laying pipes in Trenches :**

The pipe shall be laid over uniform relatively soft fine grained soil found to be free of presence of hard objects such as large flints, rocky projections, large tree roots etc. The width of the trenches shall be minimum width required for working.

The pipes laid underground shall not be less than one metre from the ground level. The pipe shall be positioned in the trenches so as to avoid any induced stresses due to deflection. Any deviation required shall be obtained by using proper type of rubber ring joints.

**Mode of measurements & payment:**

The description of each item shall unless otherwise stated, be held to include where necessary, conveyance, and delivery, handling, unloading, storing fabrication, hoisting, all labour for finishing to required shape and size; testing, fitting in position, straight, culling and waste, return of packing etc.

The length shall be measured on running metre basis of finished work. The length shall be taken along the centre line of the pipe and fittings. The pipes fixed to walls, ceiling, floors etc. shall be measured and paid under this item.

All the work shall be measured in decimal system as fixed in its place, subject to tolerance given below unless otherwise stated:

- (i) Dimension shall be measured to the nearest 0.01 metre,
- (ii) Area shall be worked out to the nearest 0.01 sq. metre.

All measurements of culling shall unless otherwise stated be held to include the consequent waste.

In case of filling of unequal bore, the largest bore shall be measured for the test.

Testing of pipe lines filling sand joints include for providing all plant and appliances necessary for obtaining access to the work to be tested and carrying out the tests.

The rate includes galvanised steel tubing with screwed socket joints, together with all fittings (such as bends, sockets, springs, elbows, tees, crosses, short pieces, clamps and plugs unions etc.) and fixing complete with clamping wall-hooks, wooden plugs etc. and also cutting, screwing and waste and for making forged (or hand mad) bends on piping as required.

Connector shall be inserted, where required or directed. The rate also includes cutting through walls, floors etc. and their making good and painting exposed threads with anti-corrosive paint as above and testing. Where lugs are to be fixed to wall, ceiling and flooring, the rate shall not include painting of pipes, providing sleeves and sand Oiling under floor for which separate payment shall be made.

The unit rate shall be for a unit of one running metre.

#### **Item No. 69 & 70**

**Providing and fixing to wall ceiling and floor 10.0 Kg./Cm<sup>2</sup> working pressure polythene pipes of the following outside Dia. Low density, complete with special flange compression type fittings, wall clipsetc. including making good the wall ceiling and floor.**

**(F)75 mm**

**(G)110 mm**

#### **Materials :**

The low density polythene pipe of specified diameter with 10 Kg./F. Sq. Cm. working pressure shall conform to I.S. 3076-1968. The specials and fillings required shall be of best quality.

#### **Workmanship:**

The P.V.C. Pipes of specified diameter shall be fixed as directed. Due to thermal expansion of rigid P.V.C. Pipes, due allowance shall be made particularly in over ground pipe lines for any change in length of pipe line which may occur during installation or when pipe line is in service.

Above ground installation of rigid P.V.C. pipe should be undertaken after precautions are observed for their protection against dirt sun rays and mechanical damage.

The rigid P.V.C. pipe lines should not be kept exposed above ground when it passes through public place, railway lines, roads, road side and footpaths.

P.V.C. pipes shall be supported at the followings intervals : 20 mm dia. 500 mm, 25 mm. dia. 750 mm, 32 mm. dia.900 mm.

Closet support spacings shall be provided, if recommended by the manufacturer.

The guide line indicated by the manufacturer regarding handling, transportation, storing, laying and jointing of pipes shall be kept in view during execution.

P.V.C. pipes shall be fixed on wall with wooden plugs and suitable clamps.

#### **Jointing the pipes :**

The pipes and sockets shall be accurately cut. The ends of the pipes and filling should be absolutely free from dirt and dust The outside surface of the pipes and the inside of the fillings shall then be roughened with emery paper, and then solvent cement shall be applied to the matching surface and pushed home and joint. Since solvent cement is aggressive to P.V.C. care must be taken to avoid applying excessive cement to the inside of pipe sockets as any surplus cement cannot be wiped off after jointing. Empty solvent cement tins,

brushes, rags, of paper unpregneted with cement should not be buried in the trenches. They should be gathered, not left scattrred about, as they can prove to be a hazard to Ahimals which may chew them.

If any manufacturer recommends its own methods of jointing the same shall be adopted after necessary approval from the Engineer-in-charge.

#### **Laying pipes in trenches :**

The pipes shall be laid over uniform relatively soft fine grained soil found to be free of presence of hard objects such as large flints, rocky projections, large tree roots etc. The width of the trenches shall be minimum width required for working.

The pipes laid underground shall not be less than one metre from the ground level. The pipe shall be positioned in the trenches so as to avoid any induced stresses due lo reflection. Any deviation required shall be obtained by using proper type of rubber ring joints.

#### **Mode of measurements & payment:**

The relevant specifications of item No. 69 shall be followed except that the P.V.C. pipes of specified dia. shall be paid under this item.

The rate shall be for a unit of one running metre.

#### **Item No. 71**

**Constructing brick masonry chamber for underground C.I. Inspection chamber and bends with bricks having crushing strength not less than 35Kg. Cm<sup>2</sup> in C.M. 1:5 C.I. cover with frame (Light duty) 455mm x 610mm internal dimensions total weight of cover with frame to be not less than 38Kg.. (Wt. of cover 23 Kg.) and Wt. of frame 15Kg. ) (R.C.C. top slab with 1:2:4 mix (1-cement :2- coarse sand :4-graded stone aggregate 20mm size) foundation concrete 1:5:10 inside plaster 15mm thick with cement mortar 1:3 finished smooth with a floating coat of neat cement on walls and bed concrete etc. complete.(i) Inside dimensions 455mmx 610mm and 450mm deep for single pipe line. (more than 10 ton)**

#### **Materials:**

Water shall conform to M-1. Cement shall conform to M-3. Coarse sand shall conform to M-4. Brick shall conform to M-9. stone aggregate shall conform to M-5A. Brick bat shaft shall conform to M-8. M.S. bar shall conform to M-11.

#### **Workmanship**

C.I. inspection chamber with provision of C.I. bends of specified size with bolts, nuts and left washers for underground drain shall be enclosed in masonry chamber which shall be constructed as under:

The excavation shall be done true to dimensions and levels shown on the plans or as directed.

The chamber shall be of size 455mm. x 610mm. internal clear dimensions between the masonry wall faces.

The height of 600mm. shall be measured from the top of the bed concrete to the top of the C.I. frame.

The excavations shall be done true to dimensions and levels shown on the plans or as directed.

Bed concrete shall be 15 cms. thick C.C. 1:5:10 (1 cement; 5 coarse sand; 10 grade stone aggregates). The projection of bed concrete beyond the masonry walls shall be 10 cms.

The walls of chamber shall be constructed in brick work with C.M. 1:5 and 23 cms. thick as per relevant specifications of brick masonry works.

The walls and bed concrete of chamber shall be plastered inside with 12mm. thick cement plaster 1:3 (1 cement; 3 fine sand) finished smooth.

The cover slab of RCC 1:2:4 (1cement: 2 coarse sand: 4 graded stone aggregate 20 mm nominal size) 15 cms thick reinforced with 10mm. bars at 15 cms. C/C both ways, surface and edges finished fair, full bearing equal to the width of the wall shall be given to the slab on all sides. The frame of manhole cover shall be embedded firmly in RCC slab so that the top of the frame remains flush with the top of RCC slab.

**Mode of measurement and payment**

The earth work in excavation providing and laying C.I. inspection chamber and bends shall be measured and paid for separately.

The earth work and excavation, providing and construction complete chamber, cost of connecting pipes with the chamber etc. included in the rate of the Description.

The rate includes all labour and materials required for the satisfactory completion of this Description as described above.

The rate shall be for a unit of one number.

**Item No. 72**

**Providing and fixing Gun metal check or non-return fullway wheel valve.(C) 25mm dia.**

**Materials:**

The gunmetal check or non-return full way wheel valve of specified dia. Shall conform to I.S. 778 1964. The non-return valve shall be of tested quality.

**Workmanship:**

The gunmetal check or non-return valve shall be fully cleared of all foreign matter before fixing.

The fixing of valve shall be done by means of bolts nuts and 3 mm rubber insertions with flanges of spigot and socketed tailpieces, drilled to the same specification as in case of socket and spigot and with flanges in case of flanged pipes. The jointing shall be done leak proof.

**Mode of measurements and payment:**

The rate includes all labours, materials, tools and plant etc. required for satisfactory completion of this Description.

The rate shall be for a unit of one number.

**Item No. 73**

**Supplying Rotationally moulded HDPE storage tank with ISI Mark of approved make incl. all taxes transportation octroi etc. complete. Storage Tanks With ISI Mark (with outside Black colour & inside lining)**

**500 Litre**

**Materials:**

Polyethylene water storage tanks shall be as per IS 12701 this material should be light weight, nontoxic all fitting material shall be H.D.P.E. brass.

The PVC tank shall be of ISI mark and approved quality and brand like infra or sintex or equivalent. Construction should provide tank of different of as per actual requirement at each portion of building.

The thickness of PVC materials shall be as per companies' specification. The size of tank shall be decided by Engineer- in -charge.

Water tank shall be installed on perfectly plained and smooth surface.

Outlet pipe shall be 7.5 cm. Light then bottom surface.

Dia of overflow pipe shall be bigger than inlet pipe dia

Unions shall be based in inlet & outlet pipe.

For connection in water tank required washer and check nuts shall be used.

All joints shall be of leak proof.

**Mode of Measurement and Payment:**

The payment shall be made as No basis

Rate shall be inclusive of placing, lifting, storing and making connection for inlet, outlet Overflow pipe with all necessary plumbing work and material for complete Description.

**Item No. 74**

**Providing erecting and fixing double coated ISI water tank of required capacity each with all necessary fitting and connection etc. complete on terrace.**

A) Storage Tank with ISI mark(with outside black colour & inside lining)

5000 lit capacity

**Material**

Polyethylene used for manufacture of tanks and manhole lids may be high density (HDPE), low density (LDPE) or linear low density (LLDPE) and shall conform to IS 10146. Polyethylene shall be compounded with carbon black so as to make the tank resistant to ultra violet rays from the sun. The percentage of carbon black content in polyethylene shall be  $2.5 \pm 0.5$  percent and it shall be uniformly distributed. The materials used for the manufacture of tank, manhole lid and fittings shall be such that they neither contaminate the water nor impart any taste, colour, odour or toxicity to water.

**Manufacture and Finish**

The tanks shall be manufactured by rotational moulding process. Each tank and the manhole lid shall be single piece having arrangement for fixing and locking the manhole lid with the tanks. Excess material at the mould parting line and near the top rim shall be neatly cut and finished. The internal and external surface of the tanks shall be smooth, clean and free from hidden internal defects like air bubbles, pit and metallic or other foreign material inclusion. Capacity of the tank, minimum weight of the empty tank (without manhole lid) and the manufacture brand name shall be embossed on the top surface of the tank near manhole.

**Shape, Size and Capacity**

The tank shall be cylindrical vertical with closed top having a manhole. Diameter and height of the tank of various capacities shall be as per manufacturer's specifications and a clearance of  $\pm 3$  percent shall be permitted on these dimensions. Capacity of the tank or up to the bottom of the inlet location whichever is less. Capacity of the tank shall be specified. Extra capacity if any shall be ignored.

**Weight and Wall Thickness**

Minimum weight of the empty tank (exclusive of manhole lid fittings) and the minimum wall thickness of top, bottom and sides shall be specified in Table 18.23. Wall thickness shall be checked beyond 150 mm of the edge where the direction the plane of tank surface changes.

**Installation and Fittings**

The flat base of the tank shall be fully supported over its whole bottom area on a durable rigid flat and level platform sufficiently strong to stand without deflection the weight of the tank when fully filled with water. Depending upon the capacity and location tanks may be suitably anchored as per the directions of the Engineer-in-Charge. For inlet, outlet and other connections fully threaded GI, HDPE or PVC connections with hexagonal check nuts and washers on either side of the tank wall shall be provided. Holes for threaded connections shall be drilled and not punched. Pipes entering or leaving the tank shall be provided with unions and suitably supported on a firm base to avoid damage to the tank walls.

**Manhole Lid**

The lid shall rest evenly and fit over the rim of the manhole so as to prevent the ingress of any foreign matter into the tank. The lid shall be provided with suitable arrangement for locking it with the tank. The tank and its components shall conform to the local bye-laws for preventions of mosquito menace.

**Measurements**

Dimensions shall be measured to the nearest cm. and weight of the empty tank shall be recorded to the nearest 100g. Capacity of the tank as defined in table shall be calculated to the nearest litre

**Table**

SR. NO	Capacity in Litres	Wall Thickness in MM	Minimum Wt of Empty Tank in Kg	SR. NO	Capacity in Litres	Wall Thickness in MM	Minimum Wt of Empty Tank in Kg
1	200	4.4	7.8	11	2500	8.2	81.00
2	300	4.4	9.0	12	3000	8.8	96.00
3	400	5.5	15.0	13	4000	10.4	138.00
4	500	6.0	18.0	14	5000	10.7	191.00
5	700	6.6	23.50	15	6000	10.7	209.00
6	1000	7.0	33.00	16	7500	10.7	250.00
7	1250	7.0	40.00	17	10000	11.5	363.00
8	1500	7.0	47.00	18	15000	11.5	550.00
9	1700	7.0	54.00	19	20000	13.2	814.00
10	2000	8.2	64.00				

**Rates**

The rate shall include the cost of the tank, manhole lid, carriage and delivery at the place specified. **Unit per Liter**

**Item No. 75**

**Providing and supplying ISI Standard R.C.C. pipes(of Sulphate Resisting Cement) in standard lengths of following class and diameter suitable for either collar joints or rubber ring joints including all taxes, insurance, transportation, freight charges, octroi, inspection charges, loading, unloading, conveyance to departmental stores, stacking etc. complete. Note : One collar should be supplied with each full length plain ended RCC pipe, cost included in rates below. One rubber ring should be supplied with each full length socketed pipe, cost included in rates below.**

**Class NP3 Test Pressure 0.7 Kg./sq.cm**

**200 mm dia pipe ID**

**Manufacturing****General**

The method of manufacture shall be such that the form and the dimensions of the finished pipes are accurate within the limits specified in relevant clause of IS: 458. The surfaces and edges of the pipes shall be well defined and true, and their ends shall be square with the longitudinal axis. The ends of the pipes shall be further reinforced by an extra ring of reinforcement to avoid breakage during transportation.

The RCC pipes rubber rings shall be systematically checked for any manufacturing defects by experienced supervisors so as to maintain a high standard of quality.

The Employer's Representative shall at all reasonable times have free access to the place where the pipes and rubber rings are manufactured for the purpose of examining and testing the pipes and rubber rings and of witnessing the test and manufacturing.

All tests specified either in this Employer's Requirements or in the relevant Indian standards shall be performed by the supplier/contractor at his own cost and in presence of the Employer's Representative if desired. For this, sufficient notice before testing of the pipes and fittings shall be given to the Employer's Representative.

If the test is found unsatisfactory, the Employer's Representative may reject any or all pipes of that lot. The decision of the Employer's Representative in this matter shall be final and binding on Contractor and not subject to any arbitration or appeal.

**Materials****Cement**

Cement used for the manufacture of RCC pipes shall conform to relevant IS codes. The use of pozzolana as an admixture to Portland cement shall not be permitted.



**Aggregates**

Aggregates used for the manufacture of RCC pipes shall conform to IS: 383. The maximum size of aggregate should not exceed one third the thickness of the pipe or 20mm, whichever is smaller.

**Mixing and Curing Water**

Water shall be clean, color less and free from objectionable quantities of organic matter, alkali, acid, salts, or other impurities that might reduce the strength, durability or other desirable qualities of concrete and mortar.

**Reinforcement**

Reinforcement used for the manufacture of the RCC pipes shall be mild steel Grade I or medium tensile steel bars conforming to IS: 432 (Part-1) or hard-drawn steel wire conforming to IS: 432 (part-2). Reinforcement cages for pipes shall be as per relevant requirement of IS: 458.

**Concrete**

Concrete used for the manufacture of RCC pipes shall conform to IS: 456. The minimum cement content and minimum compressive strength of concrete shall be as per relevant requirements of IS: 458. Compressive strength tests shall be conducted on 15 cm cubes in accordance with the relevant requirements of IS: 456 and IS: 516.

**Dimensions**

The internal diameter, wall thickness and length of barrel of pipes, reinforcement (longitudinal and spiral), type of ends and minimum clear cover to reinforcement and strength test requirements shall be as per the relevant clauses/ tables of IS:458 for different classes of pipes. The tolerances regarding overall length, internal diameter of pipes or sockets and barrel wall thickness shall be as per relevant clause of IS: 458.

**Workmanship and Finish**

Pipes shall be straight and free from cracks except that craze cracks may be permitted. The ends of the pipes shall be square with their longitudinal axis so that when placed in a straight line in the trench no opening between ends in contact shall exceed 3 mm in pipes up to 600mm diameter (inclusive), and 6 mm in pipes larger than 600 mm diameter.

The outside and inside surfaces of the pipes shall be smooth, dense and hard, and shall not be coated with cement wash or other preparation unless otherwise agreed to between the Employer's Representative and the manufacturer or supplier.

The pipes shall be free from defects resulting from imperfect grading of the aggregate, mixing or moulding. The pipes shall be free from local dents or bulges greater than 3 mm in depth and extending over a length in any direction greater than twice the thickness of barrel.

The deviation from straight in any pipe throughout its effective length, tested by means of rigid straight edge parallel to the longitudinal axis of the pipe shall not exceed, for all diameters 3 mm for every meter run.

**Testing**

All pipes for testing purposes shall be selected at random from the stock of the manufacturer and shall be such as would not otherwise be rejected under the criteria of tolerances as mentioned in IS: 458. During manufacture, tests on concrete shall be carried out as per IS: 456. The manufacturer shall supply, when required to do so by the Employer's Representative the results of compressive tests of concrete cubes and split tensile tests of concrete cylinders made from the concrete used for the pipes. The manufacturer shall supply cylinders or cubes for test purposes required by the Employer's Representative and such cylinders or cubes shall withstand the tests prescribed as per IS:458. Every pressure pipe shall be tested by the manufacturer for the hydrostatic test pressure. For non-pressure pipes, 2 percent of the pipes shall be tested for hydrostatic test pressure.

The specimen of pipes for the following tests shall be selected in accordance with relevant clause of IS: 458 and tests in accordance with the methods described in IS: 3597.

- i Hydrostatic test

- ii Three edge bearing test
- iii Absorption test

**Sampling and Inspection**

In any consignment, all the pipes of same class and size and manufactured under similar conditions of production shall be grouped together to constitute a lot. The conformity of a lot to the requirements of this Employer's Requirements shall be ascertained on the basis of tests on pipes selected from it. The number of pipes to be selected from the lot for testing shall be in accordance with Table 15 of IS: 458.

Pipes shall be selected at random. In order to ensure randomness, all the pipes in the lot may be arranged in a serial order and starting from any pipe, every  $r$  the pipe be selected till the requisite number is obtained,  $r$  being the integral part of  $N/n$  where  $N$  is the lot size and  $n$  is the sample size.

All pipes selected shall be inspected for dimensional requirements, finish and deviation from straight. A pipe failing to satisfy one or more of these requirements shall be considered as defective.

The number of pipes to be tested shall be in accordance with column 4 of Table 15 of IS: 458. These pipes shall be selected from pipes that have satisfied the requirements mentioned in the above clause. A lot shall be considered as conforming to the requirements of IS: 458 if the following conditions are satisfied.

The number of defective pipes shall not be more than the permissible number given in column 3 of Table 15 of IS: 458.

All the pipes tested for various tests shall satisfy corresponding requirements of the tests.

In case the number of pipes not satisfying requirements of any one or more tests, one or two further samples of same size shall be selected and tested for the test or tests in which the failure has occurred. All these pipes shall satisfy the corresponding requirements of the test.

**Marking**

The following information shall be clearly marked on each pipe:

Internal diameter of pipe

Class of pipe

Date of manufacture and

Name of manufacturer or his registered trade-mark or both.

Jointing

**General**

Jointing of RCC pipes shall be as per the Employer's Requirements as directed by EIC as per the relevant IS. Employer may choose any of the pipe jointing technique mentioned below. After jointing, extraneous material, if any, shall be removed from the inside of the pipe and the newly made joints shall be thoroughly cured. In case, rubber sealing rings are used for jointing, these shall conform to IS: 5382.

**1. Spigot and Socket joint (Rigid)**

The spigot of each pipe shall be slipped home well into the socket of the pipe previously laid and adjusted in the correct position. The opening of the joint shall be filled with stiff mixture of cement mortar which shall be rammed with caulking tool. This joint is used for low pressure pipe line.

**2. Collar Joint (Rigid)**

After laying the RCC pipes at proper alignment and gradient their abutting faces shall be coated with hot bitumen in liquid condition by means of a brush. The wedge-shaped groove in the end of the pipe shall then be filled with a tarred gasket in one length for each joint. The collar shall then be slipped over the end of the pipe and the next pipe butted well against the tarred gasket by suitable appliances approved by the Employer's Representative so as to thoroughly compress the tarred gasket into the grooves, care being taken that the concentricity of the pipes and levels are not disturbed during this operation. The collar shall then be placed symmetrically over the end of the two pipes and the space between the inside of the collar and the outside of the pipe filled with a mixture of cement and sand, tempered with just sufficient water to have a consistency of the semi-dry conditions, well packed and thoroughly rammed with caulking tools. The joints shall be finished off with a fillet sloping at 45° to the side of the pipe. The finished joints shall be

protected and cured thoroughly as directed by the Employer's Representative. Any plastic solution or cement mortar that may have been squeezed into the inside of the pipe shall be removed so as to leave the inside of the pipe perfectly clean.

### **3. Flush Joint (Internal)**

This joint shall be generally used for culvert pipes of 900 mm diameter and over. The ends of the pipes are specially shaped to form a self-centering joint with an internal jointing space 13 mm wide. The finished joint is flush with both inside and outside with the pipe wall. The jointing space is filled with cement mortar mixed sufficiently dry to remain in position when forced with a trowel or rammer.

### **4. Flush Joint (External)**

This joint is suitable for pipes which are too small for jointing from inside. This joint is composed of specially shaped pipe ends. Each end shall be butted against each other and adjusted in correct position. The jointing space shall then be filled with cement mortar sufficiently dry and finished off flush. Great care shall be taken to ensure that the projecting ends are not damaged as no repairs can be readily affected from inside the pipe.

### **5. Spigot and Socket (Semi-flexible)**

This joint is composed of specially shaped spigot and socket ends on the RCC pipes. A rubber ring shall be lubricated and then placed on the spigot which is forced into the socket of the pipe previously laid. This compresses the rubber ring as it rolls in to the annular space formed between the two surfaces of the spigot and socket, stiff mixture of cement and mortar shall then be filled into the remaining annular space with a caulking tool.

### **6. Collar Joint (Semi-Flexible)**

This joint is made up of a loose collar which covers two specially shaped pipe ends.

Each end shall be fitted with a rubber ring which when compressed between the spigot and collar, seals the joint. Stiff mixture of cement mortar shall then be filled into the remaining annular space and rammed with a caulking tool.

### **7. Spigot and Socket Joint (Flexible)**

The RCC pipe with the rubber ring accurately positioned on the spigot shall be pushed well home into the socket of the previously laid pipe by means of uniformly applied pressure with the aid of a jack or similar appliance. The RCC pipes shall be of spigot and socket type and rubber rings shall be used, and the manufacturer's instructions shall be deemed to form a part of these Employer's Requirements. The rubber rings shall be lubricated before making the joint and the lubricant shall be soft soap water or an approved lubricant supplied by the manufacturer.

### **Cleaning of Pipes**

As soon as a stretch of RCC pipes has been laid complete from manhole to manhole or for a stretch as directed by the Employer's Representative, Contractor shall run through the pipes both backwards and forwards a double disc or solid or closed cylinder 75 mm less in diameter than the internal diameter of pipes. The open end of an incomplete stretch of pipe line shall be securely closed as may be directed by the Employer's Representative to prevent entry of mud or silt etc.

If as a result of the removal of any obstructions the Employer's Representative considers that damages may have been caused to the pipe lines, he shall be entitled to order the stretch to be tested immediately. Should such test prove unsatisfactory, contractor shall amend the work and carry out such further tests as are required by the Employer's Representative.

It shall also be ascertained by contractor that each stretch from manhole to manhole or the stretch as directed by Employer's Representative is absolutely clear and without any obstruction by means of visual examination of the interior of the pipe line suitably enlightened by projected sunlight or otherwise.

### **Testing at work site**

After laying and jointing of RCC pipes is completed the pipe line shall be tested at work site as per the following Employer's Requirements and as directed by the Employer's Representative. All equipment for

testing at work site shall be supplied and erected by contractor. Water for testing of pipes shall be arranged by the contractor. Damage during testing shall be contractor's responsibility and shall be rectified by him to full satisfaction of the Employer's Representative. Water used for the test shall be removed from pipes and not released to the excavated trenches.

After the joints have thoroughly set and have been checked by the Employer's Representative and before back filling the trenches, the entire section of the sewer or storm water drain shall be proved by the contractor to be water tight by filling in pipes with water to the level of 1.50m above the top of the highest pipe in the stretch and heading the water up for a period of one hour. The apparatus used for the purpose of testing shall be approved by the Employer's Representative. Contractor if required himself shall dewater the excavated pit and keep it dry during the period of testing. The loss of water over a period of 30 minutes should be measured by adding water from a measuring vessel at regular 10 minutes intervals and noting the quantity required to maintain the original water level. For the approval of this test the average quantity added should not exceed 1 liter/ hour/100 linear meters/ 10mm of nominal internal diameter. Any leakage including excessive sweating which causes a drop in the test water level will be visible and the defective part of the work should be removed and made good.

In case of pressure pipeline, the completed stretch of pipeline shall be tested for site test pressure. The site test pressure should not be less than the maximum operating pressure plus the calculated surge pressure, but in no case should it exceed the hydrostatic test pressure as specified in IS: 458.

#### **Support of Pipe work and Accessories**

All necessary supports, saddles, slings, fixing bolts and foundation bolts shall be supplied to support the pipe work and its associated equipment in an approved manner. Valve, meters, strainers, and other devices mounted in the pipe work shall be supported independently of the pipes to which they connect. All brackets or other forms of supports, which can conveniently be so designed, shall be rigidly built up of steel by riveting or welding in preference to the use of castings.

No point of passage of pipes through floors or walls shall be used as a point of support, except with the approval of the Employer's Representative.

After the collars and boxes or other fitting have been fixed in position, the floors, walls and roof structure will be made good by the Contractor.

#### **Storage & Shipment**

Protection of Pipes and Fittings for Shipment Except where otherwise specified all items shall have received their complete protective coatings before dispatch from the manufacturer's works and shall be additionally protected by approved means for the period of transit, storage and erection, against corrosion and accidental damage.

For the protection of pipe linings and in particular for protecting cement mortar linings from drying out, protective metal or timber discs shall be fitted over the ends of pipes and fittings. Similar timber protective discs shall be attached to all flanges of pipes and fittings, by means of bolts specifically provided for the purpose and which shall be discarded when the item is incorporated in the Works. The sleeves and flanges of flexible joints shall be wired together in suitable bundles.

#### **Storage of Pipeline Materials**

Pipes and fittings shall be stored raised off the ground, and shall be carefully supported, cushioned and wedged. Pipes shall not rest directly on one another and shall not be stacked more than four pipes high or two pipes high in the case of pipes of 500 mm diameter or over. Special care shall be taken to ensure that flexible pipes are cradled and supported in a manner that prevents any distortion of the pipes.

Couplings and joints (and all components thereof) and other similar items shall be stored in dry conditions, raised from the ground in sheds or covered areas.

Storage areas shall be carefully set out to facilitate unloading, and checking of materials with different consignments stacked or stored separately with identification marks clearly visible.

Where items to be stored have a limited shelf life or require special storage arrangements, the method of storage shall be to the approval of the Employer's Representative and in accordance with the manufacturer's instructions.

All pipes and fittings supplied as spares shall have end covers which are proof against the entry of sand and vermin. Mortar lined pipes and fittings shall have end covers which form a complete seal, provision being made to accommodate the effects of temperature changes. Pipes and fittings supplied as spares shall have a temporary white external finish and shall be stored sheltered from the direct rays of the sun.

End covers and protection shall not be removed until incorporation of the pipes and fittings into the Works.

#### **Transportation of Pipes and Fittings**

Any vehicle on which pipes are transported shall have a body of such length that the pipes do not overhang. Large pipes shall be placed on cradles and the loads properly secured during transit. The pipes shall be handled in accordance with the manufacturer's recommendations.

Approved slings shall be used and all hooks and dogs and other metal devices shall be well padded. Hooks engaged on the inner wall surface at pipe ends shall not be used. Steadying ropes shall be employed. The positions of lifting slings shall ensure that stresses and tendency towards deformation in the pipes are kept at a minimum.

Pipe handling equipment shall be maintained in good repair and any equipment which in the opinion of the Employer's Representative may cause damage to the pipes shall be discarded.

Under no circumstances shall pipes be dropped, be allowed to strike one other, be rolled freely or dragged along the ground.

#### **Inspection of Pipes and Fittings**

Before incorporating into the Works each pipe shall be brushed out and carefully examined for soundness. Damaged pipes which in the opinion of the Employer's Representative cannot be satisfactorily repaired shall be rejected and removed from Site. Damage to pipe coatings or linings shall be repaired to the satisfaction of the Employer's representative.

#### **Built-in Pipe work and other Plant**

The pipes and other Plant in water retaining structures shall, wherever possible, be built in as the work on the structure proceeds. The Contractor shall ensure that delivery of the requisite pipe work and other Plant is in accordance with the requirements of the programmer.

Where a pipe subject to thrust passes through a concrete structure or where an external seal is required, a puddle flange shall be used. The puddle flange dimensions shall be to BS 4504 but shall be un drilled. The exterior of the pipe shall be cement washed symmetrically about the puddle flange by the manufacturer for a length at least equivalent to the thickness of the wall through which it passes.

The Contractor shall be responsible through every stage of the Works for checking the correctness of the setting of built-in Plant and shall satisfy himself they are positioned in accordance with his approved drawings.

#### **Mode of Measurement and Payment:**

The measurements shall be paid per meter length of the pipe line laid, jointed and tested and measured along the center line and shall be paid according to the inner diameter of the pipes providing and as per the rates quoted by the tender in respective items of Schedule-B. The pipes may be available in Specific size in metric system. No additional payment or reduction in payment will be made for such approximate size.

No extra payment for dewatering or installing dewatering sets for pumping out such water shall be made. No extra payment for collar pits shall be made. No extra payment for cutting of pipes, if required shall be made to the Contractor.

In absence of hydraulic/flow test 20% of the amount of the laying and jointing work of pipe line work will be withheld from the running bills till satisfactory hydraulic test is given. If level for invert of pipes in not maintained by the Contractor 100% payment shall be withheld.

The Rate shall be paid for a unit of one Running meter.

**Item No. 76**

**Providing and supplying ISI mark G. I. pipes with Couplings of following class and diameter including all taxes, insurance, transportation, freight charges, octroi, inspection charges, loading, unloading, conveyance to departmental stores, stacking etc. complete. (IS -1239) (Not for well/tube well column pipe)  
Heavy Duty 50 mm**

**Materials:**

Galvanized mild steel tubes of specified dia nominal bore shall conform to I.S. 1239 Part I & II 1992 or its latest edition for mild steel tubes, tabular and other wrought iron fittings and pipes. The coating over tube shall be as per IS 4736- 1986 and its four subsequent amendments and revision shall be followed. With a length and nominal dia. as specified. The galvanized fittings, clamps, etc. required for specified dia. bore pipes shall be of best quality and make as approved by the Engineer in charge.

The fitting required of specified dia. of pipe shall be conforming to IS SP-57 (QAWSM) 1993 for Hand book on pipes and fittings for drinking water. The sizes so specified shall be strictly followed.

**Workmanship**

**Cutting, laying and jointing.**

The cutting and treading of pipe for inserting valves, fittings etc. shall be done in neat and workman like manner without damage to pipe and lining so as to leave a smooth end at the end at right angle to axis of pipe line. The cutting shall be done by hacsaw or machine cut with blade having teeth at pitch of 1 mm.

When the tubes are to be cut or rethreaded, the end shall be carefully filed out so that no obstruction to bore is offered. The ends of the tubes shall then be treaded conforming to the requirements of I.S. 554-1955 with pipe dies and taps carefully in such a manner as will not result in slackness of joints when the two pieces are screwed together.

The taps and dies shall be used only for straightening screw threads which have become bent or damaged and dies shall not be used for turning of the treads so as to make them slacks as the latter procedure may not result in a water tight joints The screw threads for tube and fittings shall be protected from edge unit they are fitted.

In jointing the tubes, the inside of the socket and the screwed of the tubes shall be oiled and smeared with white or red lead and wrapping around with a few turns of fine spun yarn round the screwed end of the tube. The end shall then be tightly screwed in the socket, tees, etc. with a pipe wrench. Care shall be taken that all pipes and fittings are properly jointed so as to make the joints complete water tight and pipes are kept at all times free from dust and dirt during fixing. But joints shall be removed after screwing. After lying, the open ends of the pipes shall be temporarily plugged to prevent access of water, soil or any other foreign matter.

Any treads exposed after jointing shall be painted or in the case of underground piping thickly coated with approved anti corrosive paint to prevent corrosion.

The width and depth of the trenches for different diameters of the tubes shall be as under For 15 to 80 mm dia tubes width of trenches shall be 30 cm and depth of trenches 60 cms.

At joints, the trenches width shall be widened where necessary. The work of excavation and refilling shall be done true to line and gradient in accordance with general specifications of earthwork in trenches.

The pipes shall be painted with two coats of anticorrosive bitumasic paint of approved quality.

The pipe shall be laid on a layer of 15 mm sand filled up to filling above the pipe so specified.

The remaining portion of trenches shall be then filled with excavated earth. The surplus earth shall be disposed of as directed.

When the excavation is done in rock, the bottom shall be cut deep enough to permit the pipe to be laid and cushion of sand 75 mm In case of bigger dial. Of tube where the pressure is very high, thrust block of cement concrete 1:2:4 (1 cement: 2 coarse sand: 4 graded stone aggregate of 20 mm nominal size) shall be

constructed on all bends to transmit the hydraulic thrust without impairing the ground and spreading it over a sufficient area if so specified.

Fixing of the tube fitting to wall ceiling and floor.

In case of fixing of tubes and fittings to the walls or ceiling, these shall run on the surface of the wall or ceiling (not incase) unless otherwise specified. The fixing shall be done by means of standard pattern, holder clamps keeping the pipes about 15 mm, clear of the wall. When it is found necessary to conceal the pipes and when specified so, chasing may be adopted or pipe fixed in ducts or recesses etc. provided that there is sufficient space to work on the pipe with usual tools.

This shall not ordinarily be buried in walls or solid floors. Where unavoidable, pipes may be buried for short distances provided that adequate protection is given against damage and where so required joints are not buried. Where required M.S. tube sleeve shall be fixed at a place a pipe is passing through a wall or floor for expansion and contraction and other movements. In case the pipe is embedded in walls or floors, it should be painted with anti-corrosive bitumatic paint of approved quality. The pipe should not come in contact with lime mortar or lime concrete as the pipe is affected by lime. Under the floors, the pipe shall be laid in layer of sand filling.

All pipes and fittings shall be fixed truly vertical and horizontal unless unavoidable. The pipes shall be fixed to walls with standard pattern clamps of required size and shape, one end of which shall be properly plugged or cemented into walls with cement mortar 1:3 (1 cement: 3 coarse sand) and the other tightened round the pipes to hold it securely. These clamps shall be spaced at regular intervals in straight length at 2 M c/c interval in horizontal run and 2.5 M interval in vertical run For pipe of 15 mm dia up to 25 mm dia the holes in the walls and floors shall be made by drilling with chisel or jumper and not by dismantling the bricks work or concrete However for bigger diameter pipes, the holes shall be carefully made of the smallest required size. After fixing the pipe the holes shall be made good with cement mortar 1:3 (1 cement: 3 coarse sand) and properly finished to match the adjacent surface.

#### **Testing of joints.**

After laying and jointing, the pipes and fittings shall be inspected under working conditions of pressure and flow. Any joint found leaking shall be redone, and all leaking pipes removed and replaced without extra cost.

The pipes and fittings as they are laid shall be tested to hydraulic pressure of 6 kg/sq.cm The pipe shall be slowly and carefully charged with water allowing all air to escape and avoiding all shock and water hammer. The draw off takes and stopcock shall then be closed and specified hydraulic pressure shall be applied gradually. The pressure gauge must be accurate. The pipes and fittings shall be tested in sections as the work of laying proceeds keeping the joints exposed for inspection during the testing.

A pit of suitable dimensions shall be dug at the point where the connection to be made with the main and earth removed up to 150 mm below the main. The flow of water in main shall also be disconnected by closing the sluice or wheel valves on the mains. The main shall first be cut. Water if any, collected in the pit shall be bailed out an ends of the pipe threaded.

The connections of distribution pipe shall be made by fixing malleable galvanized mild steel tee of the required size and fitting of such as jam nut, socket, connecting piece etc.

The testing of the joints shall be done as described above.

#### **Mode of measurements and payment.**

The description of each Description shall unless otherwise stated, be held to include where necessary, conveyance, and delivery, handling, unloading, storing fabrication, hoisting, all labour for finishing to required shape and size; testing fitting in position, straight, cutting and waste, return of packing, etc.

The length shall be measured on running metre basis of finished work. The length shall be taken along the center line of the pipe and fittings, The pipes fixed to walls, ceiling, floors, etc. shall be measured and paid under this Description.

All the work shall be measured in decimal system as fixed in its place, subject to tolerance given below unless otherwise stated.

- i) Dimension shall be measured to the nearest 0.01 metre.
- ii) Area shall be worked out to the nearest 0.01 sq. metre.

All measurements of cutting shall unless otherwise stated beheld to include the consequent waste.

In case of fitting unequal bore; the largest bore shall be measured for the test.

Testing of pipe lines fittings and joints include for providing all plant and appliances necessary for obtaining access to the work to be tested and carrying out the tests.

The rate includes galvanized steel tubing with screwed socket joints, together with all fittings (such as bends, sockets, springs, elbows, tees, crosses, short pieces, clamps and plugs unions etc) and fixing complete with clamping wall-hooks wooden plugs etc. and also cutting, screwing and waste and for making forged (or hand made) bends on piping as required. Connector shall be inserted, where required or directed. The rate also includes cutting through walls, floors, etc. and their making good and painting exposed threads with anti-corrosive paint as above and testing. Where tubes are to be fixed to wall, ceiling and flooring, the rate shall not include painting of pipes providing sleeves and sand filling under floor for which separate payment shall be made.

For purpose of calculating cubic content cross section shall normally be taken at suitable intervals i.e. at manhole or wall chamber intervals except in abnormal cases like sudden change in strata or undulating ground, etc, when they may be taken at closer intervals as approved by the Engineer in charge whose decision shall be final conclusive and binding.

Authorized width.

- a) Up to one metre depth, the width of the trenches for the purpose of measurement of excavation shall be arrived at by adding 40 cms, to the external diameter of the tube (not the socket) where a pipe is laid on concrete bed/cushing layer. The authorized width shall be the external diameter of tube plus 40 cms or the width of the concrete bed-cushioning layer whichever is more.
- b) For depths exceeding one metre an allowance of 5 cms per metre of depth for each side of the trench shall be added to the authorized width (i.e. external diameter of pipe of plus 40 cms) This allowance shall apply to the entire depth of the trench. The authorized wide thin such cases shall therefore be, equal to the depth of trench, plus external diameter or tube plus 40 cms.
- c) When more than 0netubneislai, the diameter shall be reckoned as the horizontal distance for out side to out side of the outer most pipes.
- d) Where sheeting, etc, has been provided the authorized width of the trenches at bottom shall be increased to accommodate for sheeting etc so that the clear width available between faces of sheeting is as per provisions of (a) (b) (c) above.
- e) If the side of the trench are not vertical, the toes of the side slopes shall end at the top of pipe and vertical sided trench of authorized width as per (a) (b) (c) and (d) above shall be excavated from these down to the bed of trenches.

Where the tubes are laid in trenches, the work of excavation and refilling shall be paid for separately. The rate also does not include painting of pipes and sand filling all round tubes for which separate payment shall be made. The length shall be measured on running metre basis.

The rate includes cost of all labour, materials, tools and plant required for satisfactory completion of this item.

The rate shall be for a unit of one running metre. Of laid pie with all fittings.

#### **Item No. 77**

**Providing and supplying in standard length ISI mark rigid unplasticized PVC pipes suitable for portable water with ringfit joint including cost of rings, as per IS specification no 4985/1988 including all local and central taxes, transportation, fright charges, octroi, inspection charges, loading, unloading, conveyance to the departmental stores and including cost of jointing material etc.**



**Test Pressure 6 Kg./cm<sup>2</sup>****Pipe Dia. 110 mm****Materials:**

PVC Pipe shall be confirm to M-43A

**Workmanship:****Excavation:**

The relevant specifications of Item shall be followed.

**Laying pipes in Trenches:**

The pipe shall be laid over uniform relatively soft fine grained soil found to be free of presence of hard objects such has large flints, rocky projections, large tree roots, etc. The width of the trenches shall be minimum width required for working.

The pipes laying underground shall not be less than one meter from the ground level. The pipe shall be positioned in the trenches so as to avoid any induced stresses due to deflection. Any deviation required shall be obtained by using proper type of rubber ring joints.

The guide lines indicated by the manufacturer of regarding, handling, transportation, storing, laying and jointing of pipes shall be kept in view during execution.

**Jointing the pipes:**

The pipes and sockets shall be accurately cut. The ends of the pipes and fittings should be absolutely free from dirt and dust. The outside surface of the pipes and the inside of the fittings shall then care must be taken to avoid applying excessive cement to the inside of pipe sockets as any surplus cement cannot be wiped off after jointing. Empty solvent cement tins, brushes have or paper impregnated with cement should not be buried in the trenches. They should be gathered, not left scattered about, as they can provide to be a hazard to animals, which may chew them.

If manufacture recommends its own methods of jointing the same shall be adopted after necessary approval from the Engineer-in-charge.

**Mode of measurement and payment:**

The relevant specifications of item shall be followed except that P.V.C pipes of specified dia shall be paid under this item.

The unit rate shall be for a unit of one running meter.

**Item No. 78**

**Lowering, laying and jointing R. C. C. pipes in C. M. 1:1 1/2 of following diameters in proper position, grade and alignment at all level as directed by Engineer-in-charge including conveyance from stores to site of work, labour, giving hydraulic testing as per ISI code.**

**200 mm dia pipe ID****Workmanship:**

Excavation in trenches shall be carried out as per relevant specification of item which is measured & paid separately. Laying, jointing etc shall be carried out by following method.

**Laying:**

The pipes shall be lowered into the trenches carefully, Mechanical appliances may be used. Where necessary pipe shall be laid in straight lines or with easy curves and true to line and gradient as specified. The laying of pipe shall precede upgrade of a slope. In the pipe with loose collar, the collars shall be slipped on before the next pipe is laid.

In case where the foundation conditions are unusual such as the proximity of trees or holes, under existing or proposed around in 150 mm thick cement concrete 1:5:10 (1 cement: 5 fine sand: 10 graded stone aggregate 40mmnominalsize) or compacted sand or gravel.

In case where the natural foundation is inadequate the pipe shall be laid either in concrete cradle, supported on proper foundation or on any other suitably designed structure. If concrete bedding issued,

the depth of concrete below bottom of the pipe shall be at least 1/4<sup>th</sup> of the internal diameter of the pipe subject to a minimum of 100 mm and maximum 300 mm. The concrete shall be extended up to the sides of the pipe at least a distance of 1/4<sup>th</sup> of the out sided diameter for pipes 300mm and over in diameter.

The pipes shall be laid in the concrete bedding before the concrete has set. Pipes laid in trenches in earth shall be bedded evenly and firmly as far as up to the haunches of the pipe as to safely transit the load expected from the backfill through the pipe to the end. This shall be done either by excavating the bottom of the trenches to fit the curve of the pipe or by compacting the earth under round curve of the pipe to form an even bed. Necessary provision shall be made for joints wherever required.

**Jointing:**

The joints shall be done by slipping the collar over and clear of the end of the pipe. The recess of the end of the pipe shall be filled with jute threading dipped in hot bitumen. The new pipe shall then be brought forwarded until bitumen ring in recess of first pipe is set into the recess of the second pipe. This process shall be repeated for two or three pipes which shall then be jacked up so as to thoroughly compress the bitumen. The quantity of jute and bitumen shall be just enough to fill the recess when pressed hard by jacking care being taken that no off set of the jute braiding shall be visible either enough to fill the recess when pressed hard by jacking care being taken that no offset of the jute braiding shall be visible either outside or inside of pipe. The collar shall then be set up over the joints covering equally both the pipe and leaving an even caulking space all around cement and sand mortar 1:1 ½ shall then be well punched or pressed home with a caulking tool within the caulking space. Care shall be taken that the underside of the joints is properly filled with mortar.

**Curing:**

Every joint shall be kept wet for about 10 days for maturing, the section of the pipe line laid and jointed shall be covered immediately to protect from weather effects, Minimum bore of 100 mm is considered adequate.

The joints shall be left exposed for observation.

Testing of joint:

The pipeline shall be tested as directed.

If any leakage is visible, the defective part of the work shall be made good at no extra cost.

A slight amount of sweating which is uniform may be overlooked, but excessive scarring or particular pipe or joints shall be watched for and taken as indicating a defect to be made good.

**Mode of measurements and payment:**

Pounding or bottoming of the net without any allowance for cutting and waste. The length of bends, junctions and other connections shall be included in the total length of the drainpipes. Nothing extra shall be paid for the same.

The rate shall be for a unit of one running meter

**Item No. 79**

**Lowering, laying and jointing G. I. pipes with G. I. specials of following diameters in proper position, grade and alignment as directed by Engineer-in-charge including conveyance from stores to site of work, labour, giving hydraulic testing, etc. complete**

**Pipe Dia.50 mm**

The pipes shall be laid out along the trenches in its proper position. Before lowering of G.I. pipes, in excavation trenches, the trenches shall be well inspected and shall be in proper level. If any materials such as kapchi, pointed pieces of rocks, roots of trees etc. trenches shall be excavated in true line.

The pipes after clearing shall be jointed outside the trenches by G.I. threaded Couplings and it shall be carefully lowered and laid freely in the lines shall be done in the following manner.

- a. Clean carefully both ends of pipes and make thread as per standard practice.
- b. Wrap the standard seal tap on the threaded ends after proper cleaning.

- c. Attached necessary G.I. specials like Tee, bends, elbow , nipple etc. or Tap with G.I. coupling.
- d. Each and every joints shall be tighten by wrench till the end of the thread made in the specials.
- The pipe line shall be tested to the purpose of one and half times of the working pressure in the particulars sections leaking if any shall be made good and test pressure reapplied till no further leak-ages are noticed. The line shall be tested in sections as specials shall be subjected to maximum steady pressure then the required pressure is reached on the gauge. The testing pump shall be stopped and the pressure shall be maintained with out any drop to the satisfactions of the engineer in charges.
- In the absence of satisfactory hydraulic test given by the contractor 30 % of payment will be with held from the bill.

**Item No. 80**

**Lowering, laying and jointing PVC pipes and specials of following class and diameter including cost of conveyance from stores to site of works including coat of labour, material, except cement solvent, giving satisfactory hydraulic testing as per ISI code.**

**Pipe Dia. 110 mm**

**Supply Of Material:**

The contract shall be covering manufacturing, supplying and delivering of; "UNPLASTICIZED WHITE PVC PIPES BEARING ISI MARK WITH UPVC COUPLER CONFIRMING TO RELEVANT INDIAN STANDARDS ALONG WITH SOLVANT CEMENT SOLUTION/RUBBER GASKET".

**Standards:**

- a. The UPVC Pipes and UPVC Couplers to be manufactured supplied and delivered under the scope of this contract shall be manufactured in accordance and confirming to IS:4985-1988 or its latest revision or amendments. The Pipes only shall be with ISI certification mark.
- b. UPVC Couplers shall be confirming to IS:4985-1988.
- c. Solvent Cement Solution shall be of a good quality.

**Temperature Variations:**

All the pipes and couplers to be manufactured, supplied and delivered shall be subjected to weather conditions like sun, dust, rain, wind as available in State of Gujarat. They shall be also subjected to carry and convey drinking water under variable temperature conditions ranging from 4 C<sup>0</sup> to 45 C<sup>0</sup>.

**Tender Price:**

The tender price shall include all labor, material and machinery cost necessitated to be utilized for;

- a. Proper manufacturing of the PVC Pipes/Couplers/with rubber gasket.
- b. All tests required to be undertaken at manufacturers premises.
- c. Transportation of the pipes/couplers either by Rail and/or Road services with all the covers duly and appropriately insured.
- d. Delivery of pipes/couplers with proper loading, unloading, stacking at client store as indicated by Engineer-in-charge.
- e. Further towards proper maintenance and discharged and all contractual obligations.

**Delivery Schedule:**

The delivery schedule shall be as per client requirement.

**Marking:**

The methods of marking all the pipes to be delivered under scope of contract shall ensure that all the information will remain legible even after transportation, storage in open space etc. In general, the legible and indelible marking upon the goods shall indicate the followings;

- i) ISI certification mark on each pipe.
- ii) Manufacturers brand name and/or trade mark.

- iii) Purchasers mark as "Name of client" be inscribed.
- iv) The outside diameter and pressure of pipes.
- iv) Batch number.
- v) Any other important matter that the manufacturer or purchaser deems fit to be inscribed.

**Packing And Handling:**

When the materials are transported at Railway Risk special packing as per IRCA rules are absolutely necessary for which the extra cost, if any, shall be borne in total by supplier only.

The supplier shall have proper handling instruments/equipment's and shall follow to a suitable method of handling of pipes as may be approved by Engineer, while unloading and stacking material in the stores.

**Material & Workmanship:**

8.1 General requirements of materials and workmanship shall mean any material or article either raw or finished one required to be used in the manufacturing process of Pipes.

8.2 All the material shall be new and of high quality.

8.3 In case, if material is not specified by relevant ISS for manufacturing part or the whole as item, the supplier shall prepare specification in concurrence with manufacturer and shall seek approval of Engineer prior to its use in the manufacture.

**Technical Specification For White UPVC Pipes**

**Supply Of Material**

The general requirement relating to supply of material and manufacture of White UPVC Pipes and shall be confirming to the relevant Indian Standard specification. The pipe shall be with ISI mark.

1.1 UPVC Pipes and couplers shall be confirming to and manufactured as per IS:4985-1988 OR with its latest revision or amendments.

1.2 The dimensions, material compositions, tests etc. shall be as per IS:4985/1988 or with its latest revision or amendments. Each pipe shall be marked with ISI certification mark.

1.3 The wall thickness of the pipe shall be as specified vide para 5.2 of the IS:4985-1988.

1.4 The colour of pipes & couplers shall be white.

**UPVC Couplers/Rubber Gasket**

2.1 The material composition for UPVC Coupler shall be as per the material component of UPVC Pipes as per IS:4985/1988.

2.2 The size, pressure & manufactures name shall be mark on couplers also to identify the class of coupler either class and size should be marked on couplers too or colour bends shall be as per the colour shown in IS:4985/1988 Clame No.10.1.1 given as specified below.

2.3 Agency may be asked to procure rubber gasket jointed pipes also as per requirement. Decision shall be taken by EIC in this regard.

**Solvent Cement Solution**

The quality of solvent cement solution shall be of a good quality. For each size of pipes offered for inspection sample coupler with two pieces from two pipes shall be coupled with solvent cement offered for inspection (as these are supposed to be coupled in field) and this coupled unit shall be kept for hydraulic test at requisite pressure for the stipulated time and observed for confirmation to IS:4985-1988.

The quantity of solvent cement shall be supplied as per the quantity shown in Appendix-II.

**Impact Test:**

The pipes tested for impact strength test as per IS:4985 clause No.A-1-7.1 number of test specimen shall be taken as under :

Initially, sufficient specimens shall be taken at random and at least 14 strikes are made per extrusion run. If no specimen fails (defined as fracturing or cracking through its complete wall thickness) no further test

specimen need be taken. If of the initial 14 strikes, one specimen fails, further specimens shall be taken at random and tested to ensure a total of at least 42 strikes. If during the test more than two specimens fail, the test shall be discontinued and that lot shall be rejected. The failed batches are to be segregated by the supplier in case of failure of two or less than specimen and inspecting agency will inspect only those batches which have met with the impact test without failure, as narrated above.

#### **Type test**

a) Type test capacity, test for effect on water, test for resistance to Sulfuric Acid, internal Hydrostatic pressure test for 1000 Hrs. shall be carried out at any time during the cumulative order of 200 M.T. The total no. of such type test shall however be not more than thrice during the contract period. Or shall be taken at least once during every six months irrespective of the ordered quantity.

b) The type test shall be taken by the thirdparty inspection agency and GJI-Gandhinagar jointly at the in house laboratory of the manufacturer similarly as it is taken by the B.I.S. authority or as per tender condition.

#### **Colour of pipes**

The color of the pipes shall be white.

The opacity test for white color pipes shall be as per IS:4985 clause No.6.2.

The white pipes shall bear ISI mark confirming to IS:4985-1988 or its latest amendment/revision if any.

#### **Test for PVC resin & pipe**

##### **TEST FOR PVC RESIN & PIPE**

It shall be sufficient to show the certificate of chemical test (as per IS:10151) to the inspecting authority to confirm the 'K' value to be 65 to 67.

#### **Specific Gravity and Ash Content Tests:**

These tests shall be carried out by the inspection agency as per the IS:4985-1988 OR its latest revision OR amendments. The value should be 1.45.

The density of the finished pipes shall be as per the IS specifications. The Ash Contents in P.V.C. Pipe should not exceed 7.5% w/w.

Extra 5% couplers shall be supplied, cost of which is included in the above stated rate of pipe.

#### **Tolerance in weight of pipes:**

SR NO.	DIA & PRESSURE	UNIT WEIGHT KG/METER FOR PVC PIPES INCL. COUPLER
1	63/4	0.477
2	63/3	0.668
3	63/10	1.010
4	75/4	0.688
5	75/6	0.931
6	75/10	1.443
7	90/2.5	1.443
8	90/4	0.944
9	90/6	1.334
10	90/10	2.046
11	110/2.5	0.894
12	110/4	1.369
13	110/6	1.938
14	110/10	3.077
15	125/4	1.817
16	125/6	2.637
17	125/10	3.970

18	140/2.5	1.413
19	140/4	2.223
20	140/6	3.178
21	140/10	4.995
22	160/2.5	1.884
23	160/4	2.947
24	160/6	4.139
25	160/10	6.456
26	180/4	3.553
27	180/6	5.050
28	200/2.5	2.945
29	200/4	4.562
30	200/6	6.464
31	200/10	10.182
32	225/4	5.882
33	225/6	8.349
34	250/2.5	4.603
35	250/4	7.151
36	250/6	10.419
37	280/4	9.020
38	280/6	13.10
39	315/4	11.404
40	315/6	16.427

1. Inspecting of any will take weight of pipes as per ISS sampling methods. However, the inspecting agency, if required, will take weight of more quantity of pipes offered for inspection.
2. Similarly, consignee can take weight of pipe if required, in exceptional cases.
3. (-) 1% tolerance in actual weight of pipes (vide Appendix-I) shall be allowed but in overall weight there should not be any minus tolerance i.e. minus tolerance may be compensated in overall weight. If the tolerance is in minus, the consignment shall be outright rejected. The weight of pipes as given in Appendix-I shall be considered.

#### **Payment**

Payment shall be on Rmt basis as per relevant item – dia & class in item of schedule B of the tender Item is including all taxes insurance, transportation freight charges octroi, inspection charges loading, unloading carting to store or site of work, staking etc. comp.

#### **Lowering And Laying PVC Pipes**

1. The excavation for trenches shall be done before laying of the pipes as per required depth and width so that adequate space can be made available for joint.
2. The pipe with jointing material will be supplied by department as per schedule -A
3. Pipe shall be supplied by department as mentioned in schedule A of the tender and same shall be lifted from store site to site of work at in own cost. During transportation any damage shall be occur to pipes for fittings the replacement of pipes given by the contractor at his own cost.
4. Before laying the pipes it shall be brushed through out length so that the dust and soil can be removed.
5. Reducer bends tees, and adopter etc. to be supplied by the contractor as per relevant tender item.
6. All the specials such as bends, tees, reducer, etc. shall be fixed as per instruction of engineer-in-charge in the pipeline.

7. The pipe shall be hydraulically tested during the testing no leakage shall be observed. If, leakage observed, it shall be set rightly by the contractor at his own cost as per the instruction of engineer-in-charge. 30% payment shall be made after hydraulic testing of pipeline.

**The Scope for the Item Cover**

Cost of the use and crop compensation required to be paid for getting access to pipe line alignment arranging pipes along alignment during excavated stuff etc. (Exceeding 10 mt. Width) shall be paid by contractor at his own cost.

Cost of additional excavation required for jointing clearing the site of all scrubs, bushes, and trees and dewatering where necessary.

Labour for laying pipes in trenches to correct alignment at required depth with tools, including cutting of pipes and specials if required for laying of pipes including connecting pipes to specials and appurtenances.

Cost of the scaffolding, tools and plants, ropes etc.

Protection of existing works from damage and cost of repair to the damages carried out to the existing structure, sewer line telephone/electricity cables, electric cables, electric lines, gas pipe line, irrigation pipe line etc.

Labor for making joints including jointing material for joints, tools as well as tests. Testing of pipes for leakage under water pressure and flushing the pipes after testing and construction work shall have to be arranged by the contractor at his own cost.

**Method of Measurement and Payment**

The measurement shall be recorded in running meter of pipe length laid along the centerline of axis of pipeline including tees, enlarges, reducers and bends, correct up to 0.01 m length. No payment shall be made for overlaps etc. 30% payment of this item shall be with held for satisfactory hydraulic testing. The payment shall be made on running meter basis as per relevant item of schedule B of the tender.

**Item No. 81 to 84**

**Providing and constructing Sewer manholes, scraper manholes and unit house connection chamber, as per the type design in brick masonry in C. M. 1:5 and inside and outside 15mm thick plastering in C. M. 1:3 necessary 100 mm coping with reinforcement in RCC M- 200 fixing C. I. steps and fixing manhole frame and covers (But excluding supply of manhole frame and covers) over manholes and house connection chambers and fixing Manhole covers (but excluding supplying of manhole covers) over scraper manhole etc. complete, providing and fixing safety chain wherever necessary as per the stipulations in the type design complete (excl. excavation).**

**a) Manhole type 'A' Circular type having inside diameter of 1200 mm for depth up to 1.5 mt depth ( for 150 mm to 500 mm dia sewer ).**

**i) Manhole type 'A' as above but up to 1.0 M depth.**

**ii) Extra Depth beyond 1.0 M but upto 1.5 m depth for type "A" manhole above.**

**b) Manhole type 'B' Circular type having inside diameter of 1500 mm for depth from 1.5 mt to 4.0 mt ( for 150 mm to 600 mm dia sewer ).**

**i) Manhole type 'B' as above but up to 1.5 mt depth.**

**ii) Extra Depth beyond 1.5 M but upto 4.0 m depth for type "B" manhole above.**

**Materials**

Water shall conform to M-1 cement shall conform to M-3. Burnt bricks shall conform to M-9 brick bats of 40 to 50 mm. Size shall conform to M-8 stone coarse aggregate of 20 mm. Nominal size shall conform to M-5A Grit shall conform to M-5 Cement mortar of specified proportion shall conform to M-7. The cast iron man hole cover of 560 mm dia. With frame shall conform to I.S. 1726-1966. M.H.F.C shall be supplied by

department as mentioned in schedule "B" of the tender and same is to be carted by contractor at his own cost.

**Workmanship**

The manholes of different types and size as specified shall be constructed in sewer line at such places and to such levels and dimension as shown in drawings or as directed.

**Bed Concrete**

The manhole shall be built on a bed of cement concrete 1:3:6 (1 cement : 3 coarse sand : 6 brick bats)(40 to 20 mm. Nominal size) to the thickness of the bed concrete shall be 15 cms. For manhole up to 1 m depth and 20 cms. For manholes over meter and up to 2 meters depth and 30 cms. For manholes of greater depth. Projection of bed concrete beyond the masonry wall shall be 15 cms.

**Walls**

The walls or manhole shall be carried out with burnt bricks using bricks, having crushing strength not less than 35 Kg/cm<sup>2</sup> meters in C.M. 1:3 (1 cement 3 coarse sand) The thickness of brick masonry wall shall be 230 mm. The jointing face of such brick shall be well buttered with cement mortar before laying so as to ensure full joints.

**Plaster**

The inside of wall shall be plastered 15 mm thick with C.M. 1:3 (1 cement 3 coarse sand) and finished with floating coat of neat cement. All angles shall be rounded to 7.50 cms. Radius and all rendered internal surfaces shall have impervious finish obtained by using a steel trowel. The external joints of masonry shall be finished smooth.

**Channels and Benching**

Channels shall be semicircular in the bottom half and of diameter equal to the sewer. Above the horizontal diameter, the sides shall be extended vertically to the same level as the crown of the outgoing pipe and the top edge shall be suitably rounded off. The branch channels shall also be similarly constructed with respect to the benching but at their junction with the main channel and appropriate fall suitably rounded off in the direction of flow in the main channel shall be given.

The channel and benching shall be done C.C. 1:2:4 ( cement : 2 coarse sand : 4 graded stone aggregate 20 mm nominal size) rising at a slope in line from edges of channel. The channels of the bottom of the chamber shall be plastered with C.M. 1:2 ( 1 cement : 2 coarse sand ) and steel trowelled smooth.

**Cover Slab**

The cover slab of R.C.C 1:2:4 ( 1 cement : 2 coarse sand : 4 graded stone aggregate 20 mm nominal size ) 15 cms. Thick reinforced with 10 mm. bar at 15 cms. C/C both ways, surface and edges finished fair. Full bearing equal to the width of wall shall be given to the slab on all sides. The frame of manhole cover shall be embedded firmly in R.C.C slab so that the top of the frame remains flush with the top R.C.C. slab.

**Testing**

Manhole shall be tested by filling with water to a depth not exceeding 1.2. M. as directed.

After completion of work, manhole covers shall be sealed by means of thick grease.

(A) The excavation for constructing man holes shall be paid under the various items of excavation of the tender

**(B) B.B.C.C. 1:3:6**

The specification for this shall be as per specification given in para below cement concrete be in proportion 1:3:6 ( 1 cement : 3 coarse sand and : 6 brick bats 40 to 50 mm size ) and this item provides for plain concrete. The bed concrete shall be dia of M.H + 15 cm round & 20 cm thick.

**(C) B.B. MASONRY IN CM 1:3**



1. The inside dimension of manhole shall be 1200 mm dia and the height of brick masonry in shall be up to 1.50 mt.
2. The brick masonry shall be uniformly laid and the whole work shall be executed in good and workman like manner. Four courses of works, with three joints shall exceed in height of the stack of brick piled one upon another without mortar by 25mm. The mortar joints shall not exceed 10 mm in the thickness. No brick bats or half brick to be used in the work unless absolutely necessary as closer. The brick shall be thoroughly bedded and flushed with mortar. Every joint shall be neatly struck at the close of the days work and the brick work shall be kept wet for at least 10 days. The wall shall be in plumb, line and level and masonry shall be stepped before closing of day's work in order to have proper bond between old and new work. Before starting the work the steeped joint shall be watered with cement slurry. The fresh masonry shall be protected from the direct rays of sun and rains. All bricks work shall be washed down on completion and all stains shall be removed from the face.
3. If any portion of the work is found unsatisfactory and not confirm to the specification, the portion shall be removed at the contractor own risk and cost, on receipt of order from Executive Engineer or his agent.
  - 3.1 Materials obtained from removed of masonry shall not be allowed in work for re-use.
  - 3.2 The cement mortar shall be used in portion 1 part of cement and 3 part of sand by volume.
  - 3.3 The cement mortar shall be prepared in water tight platform. Cement mortar more than ½ hour duration shall not be used.
  - 3.4 Rates are inclusive of materials labour, scaffolding, watering and racking out joints etc. complete.

**(D) Cement Concrete 1:2:4**

For R.C.C. slab work the concrete shall consist of one part of cement, two part of sand and four part of black trap metal 20 mm nominal size measured by volume. The materials of attached booklet.

The thickness of slab shall be 12 cm thick.

**Form Work**

For shuttering the form works to be used shall be of steel plates shaped and stiffened suitably with M.S angle or timber shuttering. The supporting form work shall be strong and durable in nature prepared from good quality of wood, steel or other materials as approved by Engineer-in-charge.

The form shall have sufficient strength and rigidity to hold concrete and withstand the necessary pressure of ramming and vibrating with significant reflection from the prescribed lines. The form work shall be got approved from the Executive Engineer.

The forms shall be designed as to prevent leakage of cement slurry from the concrete and maintain accurate surface. The forms shall not be removed after concreting is completed for the period until the concrete has set as per requirement.

The material shall be accurately measured by boxes. The boxes shall be strong and rigid and shall be provided with handles for convenient lifting and handling the mixes. Hand mix will not be permitted in any case during the entire work of execution. The concrete shall be thoroughly mixed in mechanically operated mixer of approved type and of adequate size and designed so as to ensure positively uniformly distributing of all components through out the mass during the mixing operation. The quantity of water used in the mix shall be minimum as required for workability as decided by the Executive Engineer. The consistency of all batches of concrete shall be uniform and within the tolerance limit specified by the Executive Engineer.

If the mechanical mixer is stopped due to any mechanical hand mixing shall be done, and at the time 10 % more cement shall be used in mixing.

Necessary slump test shall be taken during the concreting for its consistency and proportion of water shall be corrected as per requirement.

The concrete shall be conveyed from mixer to site as rapidly as practicable methods which will prevent segregation and loss of ingredients. The concrete shall not be dropped from extensive height and free fall shall be kept to minimum. In no case it shall exceed 1.00 mt. or such free fall as may be directed by the Engineer-in-charge.

The concrete shall be deposited in continuous horizontal layer in 12 cm thickness.

During and immediately after placing the concrete it shall be thoroughly compacted by means of ramming rods and placing with suitable tools.

Curing shall be done by potable water. The exposed surface from which forms have been removed shall be protected by covering as soon as possible with canvas, gun or other satisfactory materials and shall be kept moist. Curing shall be continued for a period not less than 21 days after the concrete is placed in position.

The form work including supports etc. shall be removed in such a manner as to permit the concrete to take the stress uniformly and gradually due to its own weight.

**(E) M.S. Reinforcement as Per Design**

The work shall be carried out as per direction of Engineer-in-charge.

The reinforcement shall be provided for slab and for the RCC work as directed and as per design

The reinforcement bars shall be cut to the required size. The necessary bends, hooks, overlaps, etc. shall be provided as per the design and direction.

The bars then placed, on the centering and bound properly with binding wire keeping necessary allowance for cover etc. complete.

The bars placed shall be got approved and measured by the Engineer-in-charge before concreting is started, to check whether they are as per design or not.

**(F) Cement Plaster 15 mm Thick in C.M. (1:3)**

**MIXING**

The preparation of cement mortar used for plaster work consists of one part of cement and 3 part of sand by volume. Cement and sand shall be mixed thoroughly dry in preparation as specified on water tight platform and the water shall be added to form an easily workable paste.

All joints in masonry shall be thoroughly raked out to the depth at least 20 mm and the wall shall be washed with fresh water and thoroughly wetted for six hours before plastering is done.

Patches of plastering 15 cm X 15 cm X 15 mm shall be marked approximately not more than 3.0 mt. a part to ensure even plastering in one place. Plaster shall be done in square so as to avoid appearance of cracks. The plastered surface shall be finished with cement as directed by the Executive Engineer or his agent for which no extra payment shall be made.

The mortar that falls on the ground during work should not be allowed to use. The plastered surface shall be finished smooth with cement slurry as directed by the Executive Engineer or his authorized Agent. The cement mortar shall be used within 20 to 30 minutes. The whole surface shall be wetted for ten days. The outside surface shall be cement pointed in CM 1:1 ( 1 cement :1 coarse sand).

**C.I. Steps**

The C.I. steps shall be 30 cms X 15 cms. And 2.5 cm thick. The same shall be fixed in masonry walls as per drawing or I.S standard. The sample of C.I steps to be used shall be got approved from the Executive Engineer before use.

(H) The manhole channel shall be cast in situ using CC 1:2:4 mix with black trap metal 6mm to 20mm size. The main channels and branch channels shall be formed by providing from work suitably.

The work of channel shall be carried out as per drawing of as directed. The whole benching work including channels shall be finished smooth with plaster and neat cement slurry in best workman like manner and

there are smooth curves and smooth straight lines for un constructed flow of sewerage. The benching work shall be curved continuously.

The complete work of manhole carried out as per drawing and/or as per instructions of Engineer-in-charge for A type MH. 1200 mm dia. & depth up to 1.50 mt for sewer line 150 mm to 500 mm dia and shall be paid for number for complete manhole constructed as above for any extra depth above 1.00 mt & up to 1.50 mt. The payment shall be made in relevant item of the tender on Rmt. Basis.

#### **Mode Of Measurements And Payment**

The depth of manhole shall be distance between the top of the manhole cover and the invert level of the main drain. The rate includes all labours, materials, tools and plant etc. required for satisfactory completion of this item as directed above.

The rate shall be for a unit of one number.

PROVIDING & CONSTRUCTING M.H ----DO----DO----

(B) Manhole type B circular type having inside diameter of minimum 1500 mm and depth from 1.50 m to 4.00 m ( for 150 mm to 600 mm dia sewers)

1. Manhole type B as above but up to 1.50 m depth
2. Extra depth beyond 1.50 m but up to 4.0 m depth for type 'B' manhole above.

The detail specification shall be followed of item No. C-2 except that the work is to be carried out for 1500 mm dia circular M.H. and depth from 1.50 m to 4.0 m ( for 150 mm to 600 mm dia sewers)

Payment for item (A) & (B) shall be paid as per detail of relevant item of schedule 'B' of the tender. For B type M.H up to 1.50 m depth for 1500 mm dia circular M.H. shall be paid on number basis and for extra depth 1.50 m to 4.00 m shall be paid on Rmt basis of work done.

#### **Item No. 85 & 86**

**RCC precast MH frame & cover manufacture, supply & delivery at store or at site of work precast RCC M200 frame & cover suitable to drainage MH and as per type design & drawing including cost of reinforcement MS angle or flat, curing mold work etc.**

**Heavy Duty**

**Frame suitable for 50 cm opening of MH**

**Cover suitable for 50 cm opening of MH**

The precast RCC manhole frame and cover should be conforming to IS 12592 :2002

One number of precast RCC M H frame and cover shall be provided and fixed in top slab of container. The dimensions and weight shall be as shown in in BOQ or as directed by EIC. The sample of precast RCC M H frame and cover shall be first got approved by the Engineer-in-charge before procurement and brought on site. It shall be fixed in position at site as directed by EIC.

#### **Item No. 87**

**House connection chamber light duty**

**Frame**

**Cover**

Manufacture, supply delivery at Contractor's store at site of work and fixing on top of manhole precast RCC M.20 Frame & cover suitable to drainage M.H. and as per type design including cost of reinforcement M.S. Angles or Flat, curing, mold work etc.

#### **General Specification**

R.C.C Precast manhole frame & cover shall be manufacture as per standard type design. Frame shall confirm to IS : 12592 part – II – 1991. Cover shall confirm to IS : 12592 part – I – 1988.

#### **Inspection**

Inspection of materials will be carried out at work site by the Engineer. Who shall carry out inspection as soon as material is brought on work site. Inspection will be carried out normally within one week time. The supplier has to take care of the following points.

(1) The manufacturer has to go in for one line stenciling for identifying size and class for proper separation.

(2) The unloaded material has to be stacked in manageable batches with adequate inspection space like spreading the pieces etc to permit proper inspection.

#### Transit Risk

The contractor shall bring goods at his own risk or it should be covered against the transit risk at its own cost.

#### Test Certificate

The contractor shall always provide manufacturer's test certificate in accordance with every batch/lot of goods so manufactured and supplied.

The supplier shall also produce in addition to manufacturer's test certificate as mentioned in above, the inspection certificate issued by Engineer for the same purpose.

#### Mode of measurements & payment:

The rate includes all labours-, materials, tools and plant etc. required for satisfactory completion of this item as directed above.

The rate shall be for a unit of one number.

#### Item No. 89

##### **C.I. Manhole Frame & Cover**

#### **Workmanship**

The C.I. cover 600 x 600 mm. size with frame shall be fixed on top of the brick masonry with cement concrete :1:2:4 (1 cement : 2 sand : 4 graded stone aggregate 20 mm. nominal size) 40 mm. thick and rendered smooth. The finished top of the cover shall be left about 40 mm. above the adjoining ground level so as to exclude the surface water from entering the gully trap.

#### **Mode of measurements and payment**

The rate shall be for a unit of One number.

The rate includes cost of all labour, materials, tools and plant etc. required for satisfactory completion of this item as described above.

#### Item No. 90

**Constructing brick masonry chamber for underground C.I. Inspection chamber and bends with bricks having crushing strength not less than 35Kg/Cm<sup>2</sup> in C.M. 1:5 C.I. cover with frame (Light duty) 455mm x 610mm internal dimensions total weight of cover with frame to be not less than 38Kg. (Wt. of cover 23 Kg.) and Wt. of frame 15Kg. ) (R.C.C. top slab with 1:2:4 mix (1-cement: 2- coarse sand :4-graded stone aggregate 20mm size) foundation concrete 1:5:10 inside plaster 15mm thick with cement mortar 1:3 finished smooth with a floating coat of neat cement on walls and bed concrete etc. complete.(i) Inside dimensions 455mmx 610mm and 450mm deep for single pipe line.**

#### **General**

The Description refers to provide and fix 10 cms. x 15 cms. S.W. trap with 0.455 x 0.610 mts. Clear opening sewer trap chamber with 23 cms thick B.B masonry walls in C.M. 1:6 with cement plaster inside and outside to exposed faces including fixing C.I. cover+ frame of 38 Kgs. on top sewer trap.

#### **Materials**

The stone wall sewer trap shall be of 10cms. x 15cms. size conforming to relevant I.S. 651-1980.

#### **Workmanship**

Necessary excavation shall be done as required. The foundation cement concrete of 1:4:8 shall be laid for a thickness of 15cms. The S.W. trap shall be fixed into the position on the main sewer side of the chamber as directed. Brick masonry chamber of tone brick thickness in C.M. 1:6 shall be constructed with the inside dimensions 60cms. x 45cms.

The inside of the chamber shall be plastered in 12mm. thick C.M. 1:4 and shall be finished smooth with cement slurry. The outside of the chamber shall be plastered to a depth of 30 cms. From the top of the chamber.

The Description also includes providing and laying 1:2:4 cement concrete for fixing the C.I. frame and cover. The C.I. frame and cover shall be of the specified size and it shall not weigh less than 38 Kgs. Including frame and cover and shall be painted with two coats of anti- corrosive paint of approved make.

#### **Mode of Measurements & Payments**

The rate includes costs of all materials, labour, tools plants etc. required for carrying out satisfactory completion of Descriptions as described above.

The rate shall be for a unit of one **Number**.

#### **Item No. 91**

**Extra over items 24.44 for every additional depth of 0.1M. of part thereof beyond 450mm depth for Brick masonry chamber.(i) for 455mm x 610mm size.**

The relevant specification of Item No.90 shall be follow.

#### **Item No. 92**

**Providing and fixing 50 cm wide M.S. Ladder fabricated from M.S. Flats 10 mm x 75 mm with 20 mm dia steel bar steps in double rows, @ 30 cm C/C. The include stays of 10 mm x 50 mm flats fixed at 3 meter C/C with welding anchoring and 3 coats anticorrosive paint.**

The M.S. ladder shall be used where access to elevated tanks is essential for operation and maintenance. It shall be fabricated from M.S. angles and channel section. The span of the ladder shall be not less than 60 Cms. The M.S. flats used shall not be less than 10mm x 60mm. A chequered plate of thickness 6 mm shall be provided for every step. For ease in climbing the pitch of ladder shall be restricted to 60 degrees. The rise of the steps shall be restricted to 25 cm. All M.S. surfaces shall be coated with epoxy to prevent the corrosion. The railing for the ladder shall be fabricated from 25 mm GI pipes.

#### **Mode of Measurement & Payment**

The rate shall be paid for unit of one Rmt. of the finished item

#### **Item No. 93**

**Providing and fixing at site of work M. S. iron ladder with Rly. freight, loading, unloading, carting & all taxes etc. comp as directed including paints 2 coats etc comp.**

The M.S. ladder shall be used where access to elevated tanks is essential for operation and maintenance. It shall be fabricated from M.S. angles and channel section. The span of the ladder shall be not less than 60 Cms. The M.S. flats used shall not be less than 10mm x 60mm. A chequered plate of thickness 6 mm shall be provided for every step. For ease in climbing the pitch of ladder shall be restricted to 60 degree. The rise of the steps shall be restricted to 25 cm. All M.S. surfaces shall be coated with epoxy to prevent the corrosion. The railing for the ladder shall be fabricated from 25 mm GI pipes.

#### **Mode of Measurement & Payment**

The rate shall be paid for unit of one Rmt. of the finished item

#### **Item No. 94**

**Making connection of sewer line with existing manhole including breaking into and making good the walls, floors with cement concrete 1:2:4 mix (1 cement : 2 coarse sand : 4 graded stone aggregate 20 mm nominal size) cement plastered on both sides with cement mortar 1:3 (1 cement : 3 coarse sand), finished with a floating coat of neat cement and making necessary channels for the drain etc. complete  
For pipes 100 to 250 mm diameter**

Item shall be executed as per item description and as per instruction of engineer in charge.

**Mode of measurements and payment.**

The rate shall be for a unit of one square meters.

**Item No. 95**

**Trenching in ordinary soil up to a depth of 60 cm including removal and stacking of serviceable materials and then disposing of surplus soil, by spreading and neatly leveling within a lead of 50 m and making up the trenched area to proper levels by filling with earth or earth mixed with sludge or / and manure before and after flooding trench with water (excluding cost of imported earth, sludge or manure).**

The work of gardening shall be carried out as per direction of EIC under guidance of certified horticulturalist. The work shall be first designed with the help of horticulturalist and after approval by EIC, same shall be executed. Payment of all gardening items shall be made only after survival of plants for a minimum period of three months from date of execution.

**Item No. 96**

**Supplying and stacking of good earth at site including royalty and carriage upto 5 km complete (earth measured in stacks will be reduced by 20% for payment).**

The work of gardening shall be carried out as per direction of EIC under guidance of certified horticulturalist. The work shall be first designed with the help of horticulturalist and after approval by EIC, same shall be executed. Payment of all gardening items shall be made only after survival of plants for a minimum period of three months from date of execution.

**Item No. 97**

**Supplying and stacking sludge at site including royalty and carriage upto 5 km complete (sludge measured in stacks will be reduced by 8% for payment).**

The work of gardening shall be carried out as per direction of EIC under guidance of certified horticulturalist. The work shall be first designed with the help of horticulturalist and after approval by EIC, same shall be executed. Payment of all gardening items shall be made only after survival of plants for a minimum period of three months from date of execution.

**Item No 98 to 100**

**Supplying and stacking at site dump manure from approved source, including carriage upto 5 km complete (manure measured in stacks will be reduced by 8% for payment) :**

- 4.1 Screened through sieve of I.S. designation 20 mm**
- 4.2 Screened through sieve of I.S. designation 16 mm**
- 4.3 Screened through sieve of I.S. designation 4.75 mm**

The work of gardening shall be carried out as per direction of EIC under guidance of certified horticulturalist. The work shall be first designed with the help of horticulturalist and after approval by EIC, same shall be executed. Payment of all gardening items shall be made only after survival of plants for a minimum period of three months from date of execution.

**Item No. 101****Rough dressing the trenched ground including breaking clods.**

The work of gardening shall be carried out as per direction of EIC under guidance of certified horticulturalist. The work shall be first designed with the help of horticulturalist and after approval by EIC, same shall be executed. Payment of all gardening items shall be made only after survival of plants for a minimum period of three months from date of execution.

**Item No. 102****Uprooting weeds from the trenched area after 10 to 15 days of its flooding with water including disposal of uprooted vegetation.**

The work of gardening shall be carried out as per direction of EIC under guidance of certified horticulturalist. The work shall be first designed with the help of horticulturalist and after approval by EIC, same shall be executed. Payment of all gardening items shall be made only after survival of plants for a minimum period of three months from date of execution.

**Item No. 103****Fine dressing of the ground.**

The work of gardening shall be carried out as per direction of EIC under guidance of certified horticulturalist. The work shall be first designed with the help of horticulturalist and after approval by EIC, same shall be executed. Payment of all gardening items shall be made only after survival of plants for a minimum period of three months from date of execution.

**Item No.104****Spreading of sludge, dump manure and/or good earth in required thickness as per direction of officer-in-charge (cost of sludge, dump manure and/ or good earth to be paid separately).**

The work of gardening shall be carried out as per direction of EIC under guidance of certified horticulturalist. The work shall be first designed with the help of horticulturalist and after approval by EIC, same shall be executed. Payment of all gardening items shall be made only after survival of plants for a minimum period of three months from date of execution.

**Item No. 105****Mixing earth and sludge or manure in the required proportion specified or directed by the Officer-in-charge**

The work of gardening shall be carried out as per direction of EIC under guidance of certified horticulturalist. The work shall be first designed with the help of horticulturalist and after approval by EIC, same shall be executed. Payment of all gardening items shall be made only after survival of plants for a minimum period of three months from date of execution.

**Item No. 106****Supplying & Stacking of Selection No.1 Grass at site fresh & free from weeds having proper roots in green including loading, unloading, carriage and all taxes paid etc. and as per direction of officer in charge.**

The work of gardening shall be carried out as per direction of EIC under guidance of certified horticulturalist. The work shall be first designed with the help of horticulturalist and after approval by EIC, same shall be executed. Payment of all gardening items shall be made only after survival of plants for a minimum period of three months from date of execution.

**Item No. 107 & 108**

**Grassing with selection No. 1 grass including watering and maintenance of the lawn for 60 days or more till the grass forms a thick lawn, free from weeds and fit for mowing including supplying good earth, if needed (the grass and earth shall be paid for separately).**

**In rows 5 cm apart in both directions**

**With grass Turf**

The work of gardening shall be carried out as per direction of EIC under guidance of certified horticulturalist. The work shall be first designed with the help of horticulturalist and after approval by EIC, same shall be executed. Payment of all gardening items shall be made only after survival of plants for a minimum period of three months from date of execution.

**Item No. 109**

**Preparation of beds for hedging and shrubbery by excavating 60 cm deep and trenching the excavated base to a further depth of 30 cm, refilling the excavated earth after breaking clods and mixing with sludge or manure in the ratio of 8:1 (8 parts of stacked volume of earth after reduction by 20% : one part of stacked volume of sludge or manure after reduction by 8%), flooding with water, filling with earth if necessary, watering and finally fine dressing, leveling etc. including stacking and disposal of materials declared unserviceable and surplus earth by spreading and leveling as directed, within a lead of 50 m, lift up to 1.5 m complete (cost of sludge, manure or extra earth to be paid for separately)**

The work of gardening shall be carried out as per direction of EIC under guidance of certified horticulturalist. The work shall be first designed with the help of horticulturalist and after approval by EIC, same shall be executed. Payment of all gardening items shall be made only after survival of plants for a minimum period of three months from date of execution.

**Item No. 110 to 112**

**Plantation of Trees, Shrubs, and Hedge at site i/c watering and removal of unserviceable material's as per direction of officer in charge (including cast of plant & water)**

**Trees Plant**

**Shrubs Plant**

**Hedge Plant**

The work of gardening shall be carried out as per direction of EIC under guidance of certified horticulturalist. The work shall be first designed with the help of horticulturalist and after approval by EIC, same shall be executed. Payment of all gardening items shall be made only after survival of plants for a minimum period of three months from date of execution.

**Item No. 113 to 116**

**Digging holes in ordinary soil and refilling the same with the excavated earth mixed with manure or sludge in the ratio of 2:1 by volume (2 parts of stacked volume of earth after reduction by 20% : 1 part of stacked volume of manure after reduction by 8%) flooding with water, dressing including removal of rubbish and surplus earth, if any, with all leads and lifts (cost of manure, sludge or extra good earth if needed to be paid for separately) :**

**Holes 1.2 m dia and 1.2 m deep**

The work of gardening shall be carried out as per direction of EIC under guidance of certified horticulturalist. The work shall be first designed with the help of horticulturalist and after approval by EIC, same shall be executed. Payment of all gardening items shall be made only after survival of plants for a minimum period of three months from date of execution.



**Item No 117**

**Providing and displaying of Aglaonema Butterfly having ht.30 cm 10 to 12 fresh, healthy and attractive colorful leaves, well developed in 25 cm size Earthen pot/Plastic pot & as per direction of the officer-in-charge.**

The work of gardening shall be carried out as per direction of EIC under guidance of certified horticulturalist. The work shall be first designed with the help of horticulturalist and after approval by EIC, same shall be executed. Payment of all gardening items shall be made only after survival of plants for a minimum period of three months from date of execution.

**Item No. 118**

**Providing and displaying of Araucaria cookie having ht. 1.80 m to 1.95 m, straight, well developed, fresh and healthy with lush green leaves from bottom to top in 30 cm size of Earthen pot/Plastic pot & as per direction of the officer-in-charge.**

The work of gardening shall be carried out as per direction of EIC under guidance of certified horticulturalist. The work shall be first designed with the help of horticulturalist and after approval by EIC, same shall be executed. Payment of all gardening items shall be made only after survival of plants for a minimum period of three months from date of execution.

**Item No. 119**

**Providing and displaying of Areca Palm having ht. 2.40 m to 2.70 m with 12 to 14 suckers, well developed, fresh and healthy with lush green foliage in 35 cm size of Bucket type cement pots & as per direction of the officer-in-charge.**

The work of gardening shall be carried out as per direction of EIC under guidance of certified horticulturalist. The work shall be first designed with the help of horticulturalist and after approval by EIC, same shall be executed. Payment of all gardening items shall be made only after survival of plants for a minimum period of three months from date of execution.

**Item No. 120**

**Point wiring for Light / Fan/ Bell/ Primary Point with 2-1.5 sq. mm & earth wire of 1.5 sq. mm (green) both are of ISI marked 1.1 kv grade FRLS PVC insulated multi strand copper wires upto max length of 10 mt, in below type of pipe erected with 6A Tissino Type ISI marked flush type switch / bell push and accessories erected on Metal / PVC/Wooden Box covered with 3 mm thick PC(Polycarbonate) /Acrylic/Laminated sheet. with necessary Lamp holder/ceiling rose / H.D.Connector as directed.**

**NOTE:1. For use of ZHFR/HRFR Copper wires in place of FRLS PVC wires add 5% in Item of Point wiring Item No 1-1-1 to 1-2-5 & 1-5-1 & 1-5-2.**

**(a) with medium class Rigid PVC pipe and accessories erected flushed on wall/ceiling complete  
Cat. III**

This specification is for general requirement of the installation, testing and commissioning of Electrical wiring.

**Specification:**

This Specification is drawn out for supply, installation, connection, testing and commissioning of point wiring for light points, ceiling fan points, exhaust fan points, bell points, 5A / 15 A socket outlet points, power socket outlet points, etc. This specification also includes fixing of light fixtures, ceiling fan, wall fan, exhaust fan, bell etc.

**Standards:**

The following Indian Standards, other relevant applicable Indian and International standards and Indian Electricity Rules and Regulations, Indian Electricity Act, relevant specifications, drawings and instructions issued by architect / Consultant office regarding the work, shall be followed by the tenderer.

IS	732	Code of practice for Electrical Wiring Installation (System Voltage not exceeding 650 V)
IS	1646	Code of practice for Fire Safety of Buildings (General) Electrical Installation.
IS	4648	Guide for Electrical Layout in Residential Building
IS	694	PVC Insulated Cables
IS	8130	Specifications of Conduits for Electrical Installation
IS	2509	Rigid Non-Metallic Conduits for Electrical Wiring
IS	6946	Flexible (Pliable) Non-Metallic Conduits for Electrical Installation.
IS	9537	Specification of PVC Conduits
IS	3415	Fittings for Rigid Non-Metallic Conduits
IS	1653	Rigid Steel Conduits for Electrical Wiring
IS	2667	Fittings for Rigid Steel Conduits for Electrical Wiring
IS	3419	Specification for Fittings of Rigid Non Metallic Conduits
IS	3480	Flexible Steel Conduits for Electrical Wiring
IS	3837	Accessories for Rigid Steel Conduit for Electrical Wiring
IS	1293	3 Pin Plugs and Sockets
IS	3854	Switches for Domestic Purpose

The relevant requirement of following act, rules and regulation shall also be fulfilled by the tenderer.

- Indian Electricity Act 2003 (as amended up to date)
- Indian Electricity Rules 1956 (as amended up to date)
- Regulations laid down by the Chief Electrical Inspector of the State
- Regulations laid down by the DGVCL
- Regulations of FIA of India
- Regulations laid down by the Factory Inspector of the State
- Any other regulations laid down by the local authorities

Installation of any equipment shall be done according to the guide line provided in the Installation & operation manuals of equipment manufacturers. All the Work shall be done with latest best practices in the industry.

**Point Wiring:**

The Point wiring shall include the scope of work of Supply, installation, fixing of conduits with necessary accessories, junction / pull / inspection / switch boxes and outlet boxes, Supplying and drawing of wires (of required size) including earth continuity wire, Supply, installation and connection of flush type switches, sockets, cover plates, switch plates, and fixing fan regulators, ceiling roses, button / swan holder, connector etc., for the branch wiring from the distribution board, testing and commissioning of point wiring (as describe else where in this specification) as required.

The point wiring shall include, earth continuity conductor / wire (min. 14 SWG) from the distribution board to the earth pin / stud of the outlet / switch box and to the outlet points. Unless otherwise specified on the drawings, the point wiring shall be done as follows:

**Material****PVC Conduits**

All non-metallic PVC conduits shall conform to IS: 9537. the conduit shall be plan and type as specified in IS: 9537 and shall be used with the corresponding accessories (Refer IS: 3419 specification for fittings for rigid non metallic conduits).PVC conduits shall be rigid un-plasticised, heavy gauge having 2.0 mm. wall thickness up to 20 mm. diameter conduit and 2.5 mm. wall thickness for all sizes above 20 mm. diameter.

**M.S. Conduits**

MS Conduits shall conform to IS: 1653, finished with galvanized surface. No steel conduits less than 25 mm. in diameter shall be used. Conduits shall be solid drawn or lap-welded type, with minimum wall thickness for conduits having 25mm. and above diameter.

The conduits accessories such bends, coupling etc. shall be conforming to the relevant Indian Standard specification.

The conduits shall be delivered in original bundles to the site of construction. Each length of conduits shall bear the label of manufacturers.

Rigid non-metallic, PVC conduit shall be used for all purpose while steel conduits shall be used for surface installation. Conduits shall be concealed in walls and slabs or exposed (surface mounted) as per the site requirement or specified by architect/consultant.

**Boxes**

All the boxes for switches, sockets and other receptacles, junction boxes, pull boxes and outlet boxes shall be fabricated from 2.0mm. thick mild sheet paint with two coats of red-oxide and then two coats of enamel paints as called for. Colour of the paint shall be as approved by the client. The boxes shall have smooth external finished surface. Boxes in contact with earth or exposed to the weather shall be of 2mm. mild steel and hot dip galvanized after fabrication. Separate screwed earth terminal shall be provided in the box for earthing purpose. All boxes shall have adequate no. of knock out holes of required diameter for conduits entry. Switch boxes to receive switches, socket outlets, power outlets, telephone outlets, fan regulators, etc. shall be fabricated to the approved shape and size to accommodate with adequately sized rod/hook to fix ceiling fan. The boxes shall be of minimum depth of 65mm.

Boxes installed for concealed wiring shall be provided with suitable extension rings or plaster covers as required. Boxes for use in masonry block or tiled walls shall be square cornered tile type, or standard boxes having square cornered tile type covers. These boxes shall be installed in the center of the masonry block or tiles.

Cast metal boxes installed in wet locations and boxes installed flush with the outside of exterior surface shall be gasketed.

**Cover Plate**

The cover of the boxes to receive outlet points shall be of best-anodized sheet cut to shape and size or plate of approved manufacturers.

### Switches

Switches shall conform to IS: 3854, IS: 4615. The switches shall be single pole, single or two way and shown on the drawings or as specified. They shall be of moulded type rated for 250 volt, and of full 6 / 15 A capacities. They shall be provided with insulated dollies and covers.

The switches shall be rocker operated with a quite operating mechanism with bounce free snap action mechanism enclosed in an arc resistant chamber. The switches shall have pure silver and silver cadmium contacts. The switches shall be flush modular type. The make of the switches shall be as indicated in the drawings or BOQ or make of material or as suggested and approved by the architect/consultant. The switches installed in outdoor area shall be industrial, metal clad type, and shall be provided in weather proof enclosures, complete with weather proof gasketed covers.

### Sockets

The sockets shall conform to IS: 1293. each socket shall be provided with control switch of appropriate rating. The sockets shall be moulded type, rated for volts, and either of full 5 A or 15 A capacity, as mentioned on the drawings.

Sockets shall be of three pin type; the third in being connected to earth continuity conductor. the socket shall be flush modular type. The sockets installed in machine room, plant room or wet / damp area shall be metal clad weather proof type. The finishing and make of all the sockets shall be same as light switch. The socket shall have fully spring contacts and solid brass shrouded terminals to ensure positive electrical connections.

The sockets shall be provided with automatic shutters, which open only when earth pit of the plug inserts in the socket. The socket shall be provided with three pin plug top suitable to the socket and of the same make as socket.

### Wire & Cables

The wiring shall be done with single core, FRLS / ZHFR insulated, 650/1100 volt grade, copper conductor wires / cables lay through PVC / Steel conduits as directed. The cables shall conform to IS: 694. The plain annealed copper conductors shall comply with IS: 1554. The FRLS compound shall comply with the requirements of IS: 694. It shall be applied by an extrusion process and shall form a compact homogenous body. Manufacturers name shall be provided throughout the length of cable.

**Following color of wire shall be used for the identification of power circuit.**

Single phase	Red
Three phase	Red, Yellow, Blue
Neutral	Black
Earth	Green

Unless otherwise specified in the drawings the following size of the wire/cables shall be used for internal wiring.

**For the wiring for lights, exhaust fans, ceiling fans, bell, convenience socket outlet points etc.**

From D.B. to switch boards	2.5 mm <sup>2</sup>
From switch boards to Fan / Exhaust Fan points, convenience socket outlet points.	1.0 mm <sup>2</sup>
From switch boards to Light points	1.0 mm <sup>2</sup>
Earth wire switch board to Out let point	0.75/1.0 mm <sup>2</sup>

**For the wiring of power socket outlet having not more than two 15 A power outlets**

From D.B. to first power outlet	4.0 mm <sup>2</sup>
From first power outlet to second power outlet	2.5 mm <sup>2</sup>
power socket outlet circuit having single 15 A power outlet (like water heater)	4.0 mm <sup>2</sup>
Earth wire	14 SWG or 3.0 mm <sup>2</sup>

Separate circuit shall run for each water heater, kitchen equipment, window air conditioner, and similar outlets at location as shown on drawings.

The earth continuity conductor shall be similar to circuit cables and shall be drawn through conduit along with other circuit cables. The size of the earth continuity conductor shall be as follows.

Normal cross-section area of largest associated copper circuit conductor Normal cross-sectional area of earth continuity conductor.

Normal cross-section area of largest associated copper circuit conductor	Normal cross-sectional area of earth continuity conductor.
mm <sup>2</sup>	mm <sup>2</sup>
1.5	1.5
2.5	1.5
4.0	2.5
6.0	2.5
10	6.0
16	6.0
25	16
35	16
50	16

**Installation:****Concealed / Surface Conduit Works:**

Prior to laying of conduits, the contractor shall submit for approval, the shop drawing for conduit layout indicating the route of the conduits, number and size of the conduits, location of junction / inspection / pull / outlet boxes, size and location of switch boxes, number and sizes of wires pulled through each conduits and all other necessary relevant details. Only after the drawings are approved, the contractor shall precede the work of laying of conduits.

**Laying Of Conduits:**

Conduits shall be laid before casting in the upper portion of a slab / in PCC if below flooring or otherwise, as may be instructed in accordance with approved drawings, so as to conceal the entire run of conduits and ceiling outlet boxes. Conduits shall be so laid that they are interconnected. This is required to facilitate pulling of wires from different openings in case of any of the outlet is outlets so blocked during slab casting. Vertical drops shall be cut by the contractor to sufficient depth to allow full thickness of plaster over conduits. The width of the chases will be made to accommodate the required number of conduits. The chases will be filled with cement, coarse.

When the conduits are to be embedded in a concrete member it shall be adequately tied to the reinforcement to prevent displacement during casting. Tie wire to be supplied by the contractor.

Cutting of chases in any RCC member / finished floor / already finished surface is not allowed unless prior approval of Site Engineer is taken in site instruction book. If a chase is cut in an already finished surface, the contractor shall fill the chases and finish it to match the existing finish including painting at his cost to Site Engineer's satisfaction.

Contractor shall not cut any iron bars to fix the conduits. Puncher of wooden / steel shutting for RCC slab / beams / column etc. for conduit work is also not allowed, unless Site Engineer permits in site instruction book under special conditions.

Run of conduit pipe through expansion joints in RCC members should be avoided as far as possible and if unavoidable, flexible conduit pipe should be used with ceiling outlet box on both sides of expansion joints. Conduits on surface of RCC walls / RCC members shall be avoided as far as possible and if unavoidable prior approval of Site Engineer on sample saddles, clamps screws and a minimum 5 mtr. conduit laid on surface shall be taken, to achieve best possible workmanship. Distance between 2 consecutive clamps for fixing conduit on surface shall not exceed 900 mm. wooden patties for fixing saddles / clamps shall be used. Use of roll plug / steel fastener with hard setting / sealing compound is recommended.

In case of stone masonry, necessary conduits with M.S. boxes should be placed as the masonry is in progress, since after completing masonry; it is very difficult to cut chases in wells. Special location of cement concrete shaft is also recommended to conceal conduit in stone masonry and the same shall be provided by Architect / Consultant.

Conduit laying below the flooring should be avoided. Wherever it is unavoidable G.I. pipe should be used with prior approval of Site Engineer.

**Concealed Installation With Rigid PVC Conduit:**

The conduits shall be concealed slab, floor, walls, columns etc. All the rigid PVC conduits used for concealed installation shall be as per IS: 9537 and its accessories shall be as per IS: 3459. Whenever necessary bends or diversion may be achieved by bending the conduits with the help of bending spring. No other method of bending is allowed. Conduit pipes shall be joint with the help of plain coupler fixed at the end with the help of vinyl solvent cement. No other method of joining is permissible.

Prior to fixing the conduits, the complete route shall be marked on site for the approval of consultant.

**Fixing Of Conduit:**

Conduits embedded in concrete shall be installed in the framework before pouring concrete. The conduits shall be installed above the bottom reinforcing bars, and shall provide positive work fastening of the conduit to the reinforcing rods at an interval of not more than one meter, but on either side of couplers or bends or outlet / pull / junction boxes or similar fittings, proper hold fast shall be fixed at a distance of 30 cm from the center of such fittings. Conduits embedded in the wall shall be fixed inside the chase. The chase in the wall shall be neatly made and be fixed in the manner desired. In the case of building under construction, chase shall be provided in the wall at the time of their construction and shall be filled up neatly with cement mortar 1:4 for fixing of conduit and brought to the original finish of the wall. Cutting of horizontal chase in walls is prohibited. The conduits shall be fixed inside the chase by means of staples or by means of saddles not more than 60 cm apart.

Conduits shall be so arranged as to facilitate easy drawing of wires through them. Entire conduit layout shall be done in such a way as to avoid additional junction boxes other than light points. The wiring shall be done in a looping manner. All the looping shall be done in either switch boxes or outlet boxes. Looping in junction or pull boxes are strictly not allowed. Where conduits cross building expansion joints, adequate expansion fittings or other approved devices shall be used to take care of any relative movement.

Conduits shall be installed in such a way that the junction, derivation and pull boxes shall always be accessible for repairs and maintenance work. The location of junction / pull boxes shall be marked on the shop drawings and approved by the architect / Consultant.

A minimum distance of 200 mm shall be maintained between electrical conduits and hot water lines, communication/data cables such as telephone, LAN, TV, etc. in the building. Where ever required to cross the communication / data cable, it shall be crossed as possible as towards perpendicular to each other.

No run of conduit shall exceed ten meter. between adjacent draw in points nor shall it contain more than two right angle bends, or other derivation from the straight line.

Caution shall be exercised in using the PVC conduits in location where ambient temperature is 50 dg cel. or above. Use of PVC conduits in places where ambient temperature is more than 60 dg cel. is prohibited. The entire conduits system including boxes shall be thoroughly cleaned after completion of installations and before drawing of wires. Conduits system shall be erected straight as far as possible. Traps where water may accumulate from condensation are to be avoided and if unavoidable, suitable provision for drawing the water shall be made.

All joining method shall be subject to the approval of the client.

Separate conduits shall be provided for the following system.

- 15 A power outlets.
- 5 A outlets and lighting system.
- Low voltage system.
- Telephone / intercom system.
- C.C.T.V. system.
- Sound system.
- Computer data cabling system.
- Equipment wiring.

**Conduit Joints:**

Conduits shall be joined by means of plain couplers vinyl and / or solvent cement. Where there are long runs of straight conduits, inspection type couplers shall be provided at intervals, as approved by the client. The conduits shall be thoroughly cleaned before making the joints. In case of plain coupler joints, proper jointing material like a vinyl solvent cement (gray in color) or any material as recommended by the manufacturer shall be used.

**Bends In Conduit:**

Whenever necessary, bends or diversions may be achieved by bending the conduits or by employing normal bends. No bends shall have radius less than 2.5 times outside dia. of the conduits. Heat may be used to soften the PVC conduit for bending, but while applying heat to conduit, the conduit shall be filled with sand to avoid any damage to the conduit.

**Outlets:**

All the outlets or fittings, switches etc. shall be boxes of substantial construction. In order to minimize condensation or sweating inside the conduits, all outlets of conduit system shall be properly drained and ventilated, but in such a manner as to prevent the entry of insects, etc. Fixing between conduit and boxes, outlet boxes, switch boxes and the like must be provided with entry spouts and smooth PVC bushes. Joints between conduits and any type of boxes shall be affected by means of conduit couplers in to each of which shall be coupled smooth PVC bush from inside the box. In any case all the joints shall be fully watertight.

**Bunching Of Cables:**

Cables of AC supply of different phase shall be bunched in separate conduits. The number of insulated wires/ cables that may be drawn into the conduits shall be as per the following table. In this table, the space factor does not exceed 40%. However, in any case conduits having lesser than 19 mm dia. shall not be used. Maximum permissible number of 650/1100 volt grade single core wire/cables that may be drawn in rigid PVC conduits.

Cable Size	Size of Conduits in mm				
	19/20	25	32	38/40	50/51
mm <sup>2</sup>					
1.5	4	8	15	-	-
2.5	4	6	10	-	-
4.0	2	4	8	12	-
6.0	1	4	6	10	-
10	1	3	5	8	-
16	-	2	4	5	12

Wires carrying current shall be so bunched in the conduit that the outgoing and return wires are drawn in the same conduit. Wires originating from two different phases shall not be run in the same conduit.

#### **Installation With Rigid Steel Conduits:**

All conduits and its accessories shall be of threaded type and under no circumstances pin grip type or clamp type accessories be used.

##### **Fixing Of Conduits**

Conduit pipes shall be fixed with heavy gauge spacer bar saddles. The saddles shall be of 3 mm x 19 mm galvanized mild steel flat, properly treated and securely fixed to support by means of nuts and bolts raw bolts, brass machine screws, as mentioned, at an internal of not more than one meter but on either side of couplers, or bends, or junction / pull / outlet boxes or similar fittings, saddles shall be fixed at a distance of 30 cm from the center of such fittings. Draw boxes shall be located at convenient location for easy drawing of wires.

Every mains and sub mains shall run in an independent conduit with an independent earth wire of specified capacity along the entire length of conduit.

The conduits to be installed shall be of ample cross section area to facilitate the drawing of wires. The diameter of the conduit shall be selected as per table specified in this specification. But in no case it shall be less than 25 mm diameter.

Entire conduit layout shall be done such as to avoid additional junctions boxes other than for outlet points. Conduits shall be free from sharp edge and burrs. Conduits shall be laid in a neat and organized manner as directed and approved by the client. Conduit runs shall be planned so as not to conflict with any other services pipe, lines /duct.

The entire conduit system shall be electrically and mechanically continuous and shall be bonded together by means of approved type earthing clamp and earthed through a bare copper conductor of 14 SWG to the earthing terminals on the nearest distribution board.

If required, connection between PVC and steel conduits shall be through a junction box. Direct connection between PVC and steel conduits are not allowed.



Where exposed conduits are suspended from the structure, they shall be clamped firmly and rigidly to hangers of design to be approved by client. Where hangers are to be anchored to reinforce at the time of concrete, appropriate insets and necessary devices for their fixing shall be left in position at the time of concreting, making holes and opening in the concrete will generally not be allowed. In case, it is unavoidable, prior permission of the client shall be obtained.

**Conduit Joints:**

Conduits pipes shall be joined by means of screwed couplers and screwed accessories, as per IS: 2667. The threads shall be free from grease or oil. In long distanced straight runs of conduit, inspection type couplers two way junction boxes at reasonable intervals shall be provided or running threads with couplers and lock nuts shall be provided. The bare threaded portion shall be treated with anti-corrosive paints. Threads on conduit pipes in all cases shall be between 11mm to 27mm long, sufficient to accommodate pipes to full threaded portion of couplers or accessories. Cut ends of conduit pipes shall have no sharp edges or any burrs left, to avoid damage to the insulation of conductors while pulping them through such pipes.

Brass female bushes shall be used in each conduit termination in a switch box, outlet box, electrical panel or any other box. Conduit shall be secured in each outlet box switch box, electrical panel or any other box by means of one brass hexagonal lock nut and bush, outside and inside the box.

At each building, expansion joints approved oil tight double wire wound flexible steel conduit or any other approved method shall be used. This shall be united on both sides with the rigid conduits by suitable union. Conduits installed in the plant room for mechanical equipment shall be properly clamped with the mechanical supports, but in no case, it shall be fixed with the body of the equipment. The connection of conduit to the mechanical equipment shall be through oil tight double wire wound flexible steel conduit. In any case the length of the flexible conduit shall not exceed one meter. The flexible conduit shall be properly clamped with any cover or any removable part of the equipment.

**Bends And Conduits:**

All necessary bends in the system including diversion shall be done by bending pipes or by inserting suitable solid or circular inspection type normal box or similar fittings. Conduit fittings shall be avoided as far as possible on conduit system exposed to weather, where necessary, solid type fittings shall be used. Radius of such bends in conduit pipes shall be not less than 75mm. No length of conduit shall have more than the equivalent of four quarter bends from outlet, the bends at the outlets not bending counted.

**Protection Against Dampness:**

In order to minimize condensation or sweating inside the conduits, all outlets of conduit system shall be properly drained and ventilated, but in such a manner as to prevent the entry of insects, as far as possible.

**Protection Of Conduit Against Rust:**

The outlet surface of the conduits including bends, junction boxes, etc., forming part of the conduit system shall be adequately protected against rust, particularly when such system is exposed to weather. In all cases, no bare / threaded portion of conduit pipe shall be allowed unless such bare threaded portion is treated with anti-corrosive coating or covered with approved plastic compound.

**Bunching Of Cables:**

Unless otherwise specified, insulated conductors of different phases shall be bunched in separate conduit. Wires carrying current shall be so bunched in the conduit that the out going and return wires are drawn into the same conduit. Wires originating from two different phases shall not be run in the same conduit. The number of insulated wires / cables that be drawn into the conduits shall be as per the following table. Maximum permissible number of 650/1100 volt grade single core wire/cables that may be drawn in rigid Steel conduits.

Cable Size	Size of Conduits in mm
------------	------------------------

mm <sup>2</sup>	20	25	32	38	51
1.5	5	10	14	-	-
2.5	5	8	12	-	-
4.0	3	6	10	-	-
6.0	2	5	8	-	-
10	-	4	7	6	-
16	-	3	5	6	-
25	-	-	3	4	6
35	-	-	2	3	5
50	-	-	-	-	4

#### **Installation Of Ceiling / Wall Outlet Boxes For Lights / Fans**

Outlet boxes shall be protected at the time of laying by filling with jute / earth / cotton etc. so that no cement mortar finds its way inside during concreting or plastering etc. typical sketches for such outlet boxes shall be supplied along with other working drags. In beams conduit socket shall be provided in place of outlet boxes. The same shall be used for installation of light/fan etc.

For fixing light fixtures / brackets, outlet boxes complete with check nut for holding conduits shall be used. For lighting fixture suitable for 20 watts fluorescent tubes / incandescent lamps / mercury vapor lamps, only one outlet box is required. For fixing lighting suitable for 40 watts fluorescent lamps, two numbers outlet boxes should be provided at a distance of 300 mm. away from the centre in the longitudinal direction of the fixture, so that the use of patties / roll plug etc. may be avoided, as well as wiring from outlet box to the light fitting so to be installed in RCC beam and due to heavy reinforcement at the bottom of it is not possible to provide outlet boxes simple conduit should be provided. However alternative-fixing arrangement shall be made in consultation with Architect / Consultant.

For fixing ceiling fans, circular/square outlet boxes, 100 mm. size, complete with 12 mm. dia. Mild Steel rod 300 mm. long, for holding 12 mm. dia. Mild Steel cover 125 mm. dia. at bottom shall be used.

#### **Installation Of Draw Out Junction Boxes**

Steel draw out boxes shall be provided at a convenient points on walls/ceilings to facilitate pulling of long runs of cables / wires. These shall be completely concealed with Anodized Aluminum, flush with plastic works. The location of these boxes is to be decided prior to fixing, as per site requirement and following should be treated as general guidance for deciding the location of these:

- These should be provided at a place where these are not in direct view. Recommended place is 400/450 mm. below ceiling, if conduits are running vertically.
- Junction box in the offset of bottom of RCC beam and vertical wall should not be provided.
- If junction boxes are coming side by side for two or more conduits, one common M.S. box of proper size can be used to act as junction box.
- If junction box is to be provided in ceiling, its possible should be so located that it is in line with other light / fan points.

- Junction boxes should never be used for splitting one conduit into two or more. Junction box for such functions is avoidable and for this, number of conduits to be connected to one switch board should be calculated correctly as per drawing before laying conduits in ceiling.
- Locating junction boxes on outer surface of exterior walls of building should be avoided as these are in direct view and are also exposed to weather.
- Junction boxes should never be closed permanently by plaster. Removable covering of aluminium should be provided for conduit junction boxes for M.S. junction boxes removable hylam plate should be provided. This cover may be painted with wall colour.
- Junction boxes in important rears should be avoided and can be located in toilets / corridors / service shafts and stores etc.

#### **Installation of Switch Boxes**

Switch Boxes shall be installed at 1350 mm above finished floor level unless otherwise indicated on the drawings.

Steel boxes of required sizes, shall be provided to house speed regulators of fans, switches for lights, fans, plug sockets etc. as per requirement of drawings. These should be so designed that accessories on Anodized aluminum sheet could be mounted with tapped holes and brass machine screws, leaving ample space at the back and on the sides for accommodating wires and check nuts at conduits entries. These shall be attached to conduits by means of check nuts on all walls of the boxes through which the conduits are entering. These shall be completely connected leaving edges flush with finished wall surfaces. Anodized aluminum cover should be fixed to these switch boxes by means of brass chrome plated machine screws and cup washers. Utmost care shall be taken by contractor to ensure that all switch boxes are in line and level. Inside each switch box, bolt shall be welded to receive earthing wire.

#### **Installation Of Switch And Socket**

The switch controlling the light point or fan shall be connect on the phase wire of the circuit and neutral shall be continuous, having no Fuse/MCB/RCCB or switch installed in the line except at the D.B. All fan regulators shall be fixed inside the switch boxes on adjustable flat M.S. strips / plates with tapped holes and brass machine screws, leaving ample space at the back and side for accommodating wires.

The cover plates to the switch box shall be fixed by means of sunk head brass cadmium screws. Where two or more switches and fan regulators are installed together, they shall be provided with one gang cover plate with knockouts to accommodate required number of switches, sockets and regulators.

The witch controlling the socket outlet shall be on the phase wire of the circuit. The third pin of the socket shall be connected to the earth continuity conductor of the circuit.

The switch boxes, installed back-to-back in the same wall shall be offset from each other, 150 mm horizontally, to preclude noise transmission.

#### **Cleaning And Protection Of Conduit System**

The entire conduit system including outlet boxes, junction boxes and switch boxes shall be thoroughly cleaned after completion of erection and tested for not blockage by air / sound or steel wire prior to finishing of building by air / sound or steel wire prior to finishing of building and before drawing in of cables / wires to safeguard conduit system against filling up with the plaster / cement slurry / water etc. all the outlet and switch boxes will have to be provided with temporary jute / cotton filling, covers and plugs etc. Within tendered cost which shall be replaced later on by hylem / sheet cover after wiring as required.

#### **Drawing Of Conductors**

The drawing and joining of copper conductor or wires shall be executed with due regard to the following precautions, while drawing insulated wires into the conduits, care shall be taken to avoid scratches and kinks which may cause breakage of conductors. There shall be no sharp bends.

Insulation shall be shaved off for a length of 15 mm at the end of wire like sharpening of a pencil and it shall not be removed by cutting it square or ringing.

FRLS insulated copper conductor wire ends before connection shall be properly soldered (at least 15 mm length) with soldering flux / copper solder, for copper conductor. Strands of wires shall not be cut for connecting to the terminals. All strands of wires shall be soldered at the terminals. All strands of wires shall be soldered at the end before connection. The brass-screws shall have flat ends. All looped joints shall be soldered and connected through terminals block / connectors. The pressure applied to tighten terminal screws shall be just adequate, neither too much nor too less. Conductors having nominal cross section are exceeding 4 sq. mm. shall always be provided with crimping type cable sockets. At all bolted terminals, brass flat washer of large area and approved steel spring washers shall be used. Brass nuts and bolts shall be used for all connections.

Only certified wireman and cable joiners shall be employed to do joining work.

For all internal wiring FRLS insulated wires of 650 / 1100 volts grade shall be used. The sub-circuit wiring for point shall be carried out in looping system and no joint shall be allowed in the length of the conductors. No wire shall be drawn in to any conduit, until all work of any nature that may cause injury to wire is completed. Care shall be taken in pulling the wires so that no damage occurs to the insulation of the wire. Before the wires are drawn into the conduits the conduits shall be thoroughly cleaned of moisture, dust, and dirt of any other obstruction by forcing compressed air through the conduits.

#### **Joints**

The wiring shall be by looping back system, and hence all joints shall be made at main switches, distribution boards, socket outlets, lighting outlets and switch boxes only. No joints shall be made inside conduit and junction boxes. Contractors shall be continuous from outlet to outlet. Joints where unavoidable, due to any specified reason, prior permission in wiring shall be obtained from the client before making such connections. Joints by twisting conductors are prohibited.

#### **Load Balancing**

Balancing of circuit in three phase installation shall be planned before the commencement of wiring and shall be strictly adhered to.

#### **Earthing**

All earthing systems shall be in accordance with IS: 3043 - 1985 code of practice for earthing. A separate Earthing System specification shall be provided ( Pl. ref. Doc ID : Ar0601 SE057).

#### **Installation Of Lighting Fixtures / Fans**

##### **Installation Of Lighting Fixtures**

This work includes the connections of 2 core 1.0/1.5 mm<sup>2</sup> PVC insulated wires and earth wire from 5 A pvc/Bakelite connector of light point to the connector inside the lighting fixture, connections, fixing of lighting fixture complete with all accessories, lamps on wall / roof / steel truss etc. testing the lighting fixture and commissioning. If wire length of light point is enough to reach connector of light fitting, connector in light point can be deleted.

##### **Installation Of Fan / Exhaust Fans**

This work includes the connections of 2 core 1.5 mm<sup>2</sup> PVC insulated wires and earth wire from 5 A pvc/Bakelite connector of fan / exhaust fan point to connector of fan / exhaust fan, connectors, fixing of fan in hook provided in the box, making exhaust fan opening in walls including repair / finishing of opening and fixing of exhaust fan complete with accessories and louvers on walls with hold-fasts, testing the fan / exhaust fans and commissioning.

##### **Installation Of Bracket For Street Light Fittings**

The brackets shall be made of 38 mm. NB MS class "B" pipe approx. 1.8 mtr. long bent at the center at angle 120°C. with necessary holding brackets, hold fasts etc, with special reducer at the end to accommodate type of streetlight fitting to be fixed. Bracket shall have 1 coat of anti-corrosion paint before dispatch to site and 2 coats of approved make and shade of aluminum paint. This bracket shall also be provided with one M.S./PVC watertight box complete with the connector, neutral link, earth connection, MCB, etc.

#### **Testing Of Installation**

After completion of work and before put into service, the following tests shall be carried out and requirement specified below shall fulfilled.

#### **Insulation Resistance**

The insulation resistance shall be measured by applying 500 volt megger with all fuses in places, circuit breaker and all switches closed.

The insulation resistance shall be measured between Phase to Phase, Phase to Neutral, Phase to Earth, and Neutral to Earth.

The insulation resistance shall not be less than 50 Mega Ohms divided by the number of points on the circuit.

#### **Earth Continuity Path**

The earth continuity conductors shall be tested for electrical continuity and the electrical resistance of the same along with the earthing lead but excluding any added resistance or earth leakage circuit breaker measured from the connection, with the earth electrode to any point in the earth continuity conductor in the completed installation and shall not exceed one ohm.

#### **Polarity of Single Pole Switches**

A test shall be made to verify that single pole switch is connected to one of the phase of the supply system only.

#### **Completion Certificates**

All the above tests shall be carried out in presence of client and the results shall be recorded in prescribed forms. Any fault during the testing shall be immediately rectified and that section of the installation shall be retested. The completed test result form shall be submitted to the client for approval.

On completion of an electric installation a certificate shall be furnished by the contractor, countersigned by the certified electrical supervisor (a person holding a certificate of competency issued by the (DNH Government) under whose direct supervision the installation was carried out. This certificate shall be in a prescribed form as required by the local electric supply authority.

NOTE : It is to be noted that all the liaising work with power supplying authority shall be carried out by the licensed electrical contractor including the submission of different forms, test reports, any correspondence etc. However any legal fees, estimate cost, registration fees shall be paid by Municipal Council.

#### **Item No. 121**

**Point wiring for independent PLUG with following size mains earth wire of 1.5 sq.mm (green) both are of ISI marked 1.1 KV grade FRLS PVC insulated multi strand copper wires upto 10 mt length, in following below of pipe erected complete with ISI marked 3 / 5 Pin socket and tissino type switch erected with earth continuity connection erected on Metal / PVC/Wooden box covered with 3 mm thick PC(Polycarbonate) / Acrylic/Laminated sheet.**

**NOTE:1. For use of ZHFR/HRFR Copper wires in place of FRLS PVC wires add 5% in Item of Point wiring Item No 1-1-1 to 1-2-5 & 1-5-1 & 1-5-2.**

**[A] For 6 amp plug and 6 amp switch with 2-1.5 sq. mm Cu. Mains from near by switchboard/db board upto 6 mt.**

**(a) with medium class Rigid PVC pipe and accessories erected flushed on wall/ceiling complete**

**Cat. III**

The relevant specifications of Description item No.120 shall be followed.

**Item No. 122**

**[B] 6/16A Plug and 16 amp switch with 2-2.5 sq. mm Cu. Mains from mcb d b boards.**

**(a) with medium class Rigid PVC pipe and accessories erected flushed on wall/ceiling complete**

The relevant specifications of Description item No.120 shall be followed.

**Item No. 123 & 124**

**Providing and erecting ISI mark Medium class RIGID PVC PIPES of following size complete to be erected on/in wall or ceiling erected with necessary PVC fittings & Junction boxes fixed with adhesive solution & Clamps with following dia of pipes, in approved manner as directed**

**(a) 20 mm**

**(b) 25 mm**

The relevant specifications of Description item No.120 shall be followed.

**Item No. 125 & 126**

**Providing and erecting Mains with 1.1 KV grade FRLS PVC insulated ISI marked stranded Copper conductor wire in following type of pipe to be erected concealed in /flushed on wall/ceiling, with 1.5 sq. mm copper conductor FRLS PVC insulated stranded wire of green colour for earth continuity of following size**

**(A) with medium class Rigid PVC pipe and accessories**

**(a) 2 wire 1.5 sq. mm**

**(b) 2 wire 2.5 sq. mm**

The relevant specifications of Description item No.120 shall be followed.

**Item No. 127**

**providing and erecting Mains with 1.1 KV grade FRLS PVC insulated ISI marked stranded Copper conductor wire in following type of pipe to be erected in / on wall / ceiling with 2.5 sq. mm copper conductor FRLS PVC insulated stranded wire of green colour for earth continuity of following size**

**(A) with medium class Rigid PVC pipe and accessories**

**(a) 2 wire 4 sq. mm**

The relevant specifications of Description item No.120 shall be followed.

**Item No. 128**

**Providing & erecting Approved make Ceiling Fan with double ball bearing ISI mark with Condenser 230 volt A.C.50 Hz 1200 mm sweep complete having 3 blades aluminium body and blade sets having ornamental design shanks , canopy erected with earthing. [ Make shall be approved by Engineer in Charge]**

The ceiling fans shall conform Indian Standard Specification IS:374-1979. The enclosure of motors of ceiling fans shall be of the totally enclosed type. The enclosure of regulators shall be ventilated type. The stamping of fan motors shall be made electrical steel sheet. The ceiling fans shall have three numbers well balanced blades made from metal or other suitable material. The blades and motors shall be securely fixed so that they do not loosen in operation.

The size of ceiling fans shall be as specified. The ceiling fans shall be suitable for operation on electric A.C. single phase 230 Volt, 50 Hz power supply. Proper type of lubrication bearing bearings shall be used to ensure a reasonable amount of silent operation.

The earthing terminal shall be provided on the suspension system. The live parts shall not be accessible in the assembled fan and regulator. Capacitor of the fan shall conform IS:1709-1960. The suspension system shall be either bolted or screwed at the motor end and the suspension end. The suspension system of the ceiling fans shall be of adequate strength to withstand a tensile load of 1000 Kg. without breakage and a torsion load of 500 Kg without breakage current carrying parts and other metal parts shall be corrosion resistant under normal conditions. The terminals shall be prepared from stainless steel or other corrosion resistant alloys. Radio and television interference suppressors shall be fitted.

The regulators shall be capable of reducing the speed of the fan at least 50 percent of the full speed. The regulators shall be provided with an off position and minimum five running positions excepts in case of continuously variable electronic type speed regulators the regulator handle or knob shall either be of insulating material or adequately electrically and thermally insulated metal. The mechanism of the regulator shall be so designed to ensure positive contact at each running position. The voltage drop across the electronic type regulators at the maximum speed position shall not exceed shall not exceed 2 % of the service value at the test voltage and at full speed shall be as per I.S.S.

The ceiling fans shall be connected with ISI marked twin twisted flexible wire of size not less than 24/0.2mm. The general and technical specification given in the tender booklet shall be considered as a part of agreement. The material shall be approved as per relevant IS specifications and shall be approved by the Electrical Engineer in charge before executing work.

#### **Item No. 129**

**Supplying and erecting LED indoor fittings with LEDs of wattage 0.2 Watt to 0.5 Watt assembled on single MCPCB, with housing used as a heat sink shall be made of thick sheet Steel conforming to IS: 513/CRCA/ aluminium die cast powder coated and high U.V. & corrosion resistance with diffuser with company mark/name 160V to 270V, Power Factor more than 0.9, THD < 15%, CCT 3000 K to 6500K, Luminaire efficacy > 85 lumens/watt, LED driver efficiency > 85 % (fitting required LM-79 & LM-80 Certificates)(NOTE: Below description have shown ranges of Wattage capacity of LED fittings. The Engineer incharge may select any wattage capacity between the ranges shown.)**

**(A) Tube Light with integral driver**

**(iv) 22-24 Watts, Surge - 2KV, IP-20, conventional 4 feet Cat. III**

#### **Scope :**

The specification covers the requirements of lighting fixtures for LED lamp and associated accessories. Equipment shall include lighting distribution boards, lighting fixtures, poles, switches, receptacles, conduits wires and miscellaneous hardware necessary for complete lighting work.

#### **Code and Standards :**

The design, manufacture and performance of equipment shall comply with all currently applicable statutory regulations and safety codes in the location where these fittings will be installed.

The fittings shall conform to the latest applicable Indian Standards, British Standards or IEC Standards, some of which are listed below:

- IS : 1913            General and safety requirements for electric lighting fittings.
- IS : 1777            Industrial lighting fittings, with metal reflectors.
- IS : 4012            Dust proof electric lighting fittings.
- IS : 3528            Water proof electric lighting fittings.
- IS : 2149            Luminaries for street lighting.
- IS : 1947            Specification for flood light.
- IS : 5077            Specification for decorative lighting out-fits.
- IS : 1534            Ballasts for use in fluorescent lighting (Part I) fixtures.
- IS : 1569            Capacitors for use in fluorescent lighting fixtures.
- IS : 1950            Vitreous enamel reflectors for discharge lamps.
- IS : 1391            Air-conditioners.
- IS : 10332           Specification for luminaries
- IEC 62384           DC or AC supplied electronic control gear for LED modules performance requirements
- IEC/ PAS 62612 Self-ballasted LED lamps for general lighting services- Performance requirements
- IEC 61347-2-13 Lamp control gear: particular requirements for DC or AC supplied electronic control gear for LED modules.
- IEC 61000-3-2 Electro Magnetic compatibility (EMC)- Limits for Harmonic current emission — (equipment input current  $\leq 16$  A per phase.
- IEC 60598-1        Luminaries - General requirement and tests
- Lighting Fixtures : The fixtures shall be suitable for operation on a nominal supply of 220 volts, single phase, 50 Hz +/- 5% a-c with a voltage variation of +/-10% (i.e.228 V to 252 V).
- All fixtures shall be designed for continuous operation under atmospheric conditions specified without reduction in lamp life or deterioration of materials and internal wiring. Ballast : Lighting fixture ballasts shall be designed, manufactured and supplied in accordance with the relevant standards and shall function satisfactorily under site conditions specified. The ballasts shall have a long service life and low power loss. Ballasts shall be mounted using self-locking anti-vibration fixings and shall be easy to remove without removing the fittings.
- The ballasts shall be of the inductive and heavy duty type, filled with polyster or equivalent. They shall be free from hum and protected from the atmosphere. Ballasts which produce a humming sound shall be replaced free of cost by the supplier. For multi lamp fittings, a separate choke shall be provided for each lamp.
- Starters: Lighting fixture starters shall be of the safety type (i.e. if the lamps fail to ignite at the first start, no further starting must be possible without attending to the tube light). Starters shall have bimetal electrode and high mechanical strength. Starters shall be replaceable without disturbing the reflector or lamp and without the use of any tool.
- Lighting fixture capacitors shall have a constant value of capacitance and shall be connected across the supply of individual lamp circuits.
- Each capacitor shall be suitable for operation at 220 volts + 10 % single phase 50 Hz + 5 % with a suitable value of capacitance so as to correct the power factor of its corresponding lamp circuit to the extent of 0.98 lag. The capacitors shall be hermetically sealed preferably in a metal container to prevent seepage of impregnating materials and ingress of moisture.
- Reflectors: Lighting fixture reflectors shall generally be manufactured from sheet steel or aluminium of not less than 20 SWG. They shall be readily removable from the housing for cleaning and maintenance without disturbing the lamps and without the use of tools. They shall be securely mounted to the housing by means of positive fastening devices of a captive type.

**General :**

- (i) Each fixture shall be complete with a four way terminal block for the connection and looping of incoming and outgoing supply cables. Each terminal shall be able to accept two 6 mm<sup>2</sup> solid aluminium conductors.



- (ii) Each lighting fixture shall be provided with a grounding terminal suitable for connecting 2.5 mm<sup>2</sup> stranded tinned copper grounding conductor.
- (iii) All metal or metal enclosed parts of the housing shall be so banded and connected to the ground terminal so as to ensure satisfactory grounding continuity throughout the fixture.
- (iv) On completion of manufacture, all surfaces of the fixtures shall be thoroughly cleaned and degreased. The fixtures shall be free from scale, rust, sharp edges and burrs.
- (v) The enamel finish shall have a minimum thickness of 2 Mils for outside surfaces and 1.5 Mils for inside surfaces. The finish shall be non-porous and free from blemishes, blisters and fading.
- (vi) All light reflecting surfaces shall have optimum light reflecting co-efficient such as to ensure the overall light output as specified.
- (vii) All reflectors and louvers shall be furnished to the same stranded as the fixture housing.

#### Tests

The following routine tests shall be conducted as per the relevant Indian Standards.

- (a) Each fixture shall be tested at 1500 volts r.m.s. 50 Hz for one minute and no flash over or break down shall occur between current carrying parts and ground.
- (b) Insulation resistance of each fixture shall be tested at 500 V d-c and the insulation resistance so measured shall not be less than 2 mega ohms between all current carrying parts and ground.
- (c) Each fixture complete with its proper lamp/lamps shall be shown to operate satisfactorily at its normal voltage and frequency.
- (d) Each fixture shall be examined visually to ensure that it is complete in all respects and satisfactorily finished.
- (e) Type and routine test certificates shall be submitted for tests conducted as per relevant IS/BS for the fixture and accessories.

Drawings and Data : As part of the proposal, the Bidder shall furnish relevant descriptive and illustrative literature on lighting fixtures and accessories and following drawings/data for the respective lighting fixtures :

- (i) Dimensional drawings
- (ii) Mounting details cable entry facility and weights
- (iii) Light distribution diagrams (zonal & isekandera)
- (iv) Light absorption and utilisation factors
- (v) Lamp output v/s. temp, curves.

#### **Lighting Fixtures and Layout :**

General Specification for LED Indoor Lightning :

LED indoor fittings with LEDs of wattage 0.2 Watt to 0.5 Watt assembled on ingle MCPCB, with housing used as a heat sink shall be made of thick sheet Steel conforming to IS: 13/CRCA polyester powder coated and high U.V. & corrosion resistance with diffuser and/or Polycarbonate optics with company mark/name 120 to 300 V, Power Factor more than 0.9, THD < 10 %, CCT 4000 K to 6500K, Uniformity ratio >0.7, Luminaire efficiency > 85 lumens/watt, LED driver efficiency > 85 % (Each fitting required LM-80 Certificates)

General Specification for LED Outdoor Lightning :

LED indoor fittings with LEDs of wattage 0.2 Watt to 0.5 Watt assembled on ingle MCPCB, with housing used as a heat sink shall be made of thick sheet Steel conforming to IS: 13/CRCA polyester powder coated and high U.V. & corrosion resistance with diffuser and/or Polycarbonate optics with company mark/name 120 to 300 V, Power Factor more than 0.9, THD < 10 %, CCT 4000 K to 6500K, Uniformity ratio >0.7, Luminaire efficiency > 85 lumens/watt, LED driver efficiency > 85 % (Each fitting required LM-80 Certificates)

It shall be the responsibility of the tenderer to work out a detailed layout for the lighting fixtures offered by him, in order to provide the specified levels of illumination. The tenderer shall be responsible for measuring the levels of illumination after installation and establish compliance with the specification. The number and types of fixtures offered by him shall be indicated in his tender. The final layout of the lighting

fixtures shall be furnished for the approval before commencement of installation. As per Ste requirement 2 x 18 watts LED tube light fixtures (indoor type with reflector) complete in all respect will be required to be provided for lighting of Entire Plant. Detailed layout shall be finalised at the time of detailed Engineering. As per Site Requirement 1 x 90 / 120 Watts LED Street light fixtures (outdoor type Street Light Fixture) complete in all respects will be required to be provided for of Entire Plant. Detailed layout shall be finalised at the time of detailed Engineering. As per Site requirement 1 x 90 / 120 Watts LED Flood light fixtures (outdoor type) complete in all respects will be required to be provided for lighting of Entire Plant. Detailed layout shall be finalised at the time of detailed Engineering. As per requirement Ceiling Fan comp. in all respects will be required to be provided lighting. Detailed layout shall be finalised at the time of detailed Engineering. The layout / detailed drawing for the complete plant lighting (inside and outside) must be prepared and got approved from the Consultant. Lighting fixtures for the pump-bay shall be industrial type LED complete with reflector. Street lighting shall be carried out with pole mounted LED fixtures. All other indoor areas shall be illuminated using LED tube fixtures of the industrial / decorative type, complete with reflectors. All the luminaries inside the bio gas power plant Building shall be flame proof type only. All lighting fixtures shall be supplied complete with lamps and all necessary accessories for their satisfactory operation. All lighting fixtures Outdoor type as well as indoor type shall be as per approved vendor list and LED type only. All lighting fixtures shall be complete with necessary mounting accessories Receptable units - Lighting Systems : Decorative and industrial type receptacle units of approved make of 5A, and 15A rating with switches confirming to IS : 3854 and sockets confirming to IS : 1293 shall be supplied and installed. Minimum 10 nos. of each rating shall be provided. Plant Wiring: All plant wiring shall be carried out using casing capping made from exclusivaly extrusion process using special compounded PVC resin having flat surface of casing with curved arrangement to grip the caping for fitting and holding. Casing can be scresed on surface by screw easily. No screw will be visible from outside. The wiring shall be done using copper conductor PVC wire confirming to IS-1554 with concealed plate type switches and switch boards (Make-M.K./C.P.L./Ellora/ Jainex / Anchor). The copper conductor PVC insulated earth wire shall run through-out for light and power points. It shall be the responsibility of the Contractor to work out a detailed layout for the complete plant in order to provide the levels of illumination as indicated in the relevant standards. Emergency Lighting: Emergency Lighting shall be designed such that at all junctions, exit passages & strategic locations, Lux level shall be maintained above 10 Lux. Emergency light fitting shall be 240 V self contained 10 W LED type with built in Ni-Cd battery having charging facility and six hours back-up time. Lighting cable from Main lighting DB (MLDB) to Lighting panels shall be Al / CU conductor, XLPE insulated, 1.1KV grade, laid in cable trays otherwise cleated along the wall/ column/ beam. The provision made under quality control act/order shall be followed. Each fitting shall be controlled individually. Critical Lighting shall be designed such that at all junctions, exit passages & strategic locations the Lux level shall be maintained above 10 Lux. Instal lite fixtures with built in battery backup shall be Considered.

Specific Requirements :

Illumination Levels :

The illumination levels to be considered for the design of lighting system for various areas shall be as following. These are the illumination levels achieved at Work plane.

Area Illumination Level (Lux) - Average values

- Office rooms - 300 Lux
- Switchgear rooms - 250 Lux
- Control rooms - 300 Lux
- Chemical and general stores - 150 Lux
- Chemical plant room - 200 Lux
- All other indoor areas - 150 Lux
- Outdoor platforms and walk ways - 50 Lux
- Outdoor plant areas - 50 Lux

- Transformer Area - 50 Lux
- General - 50 Lux
- On Equipment - 50 Lux
- Roads - 50 Lux
- Large tank & reservoir -50 Lux

**Item No. 130**

**Supplying and erecting led lamps with following wattage capacity of 220 to 240 voltage, minimum 15000 burning hours life, 500 V in built-surge protection, Polycarbonate diffuser, mounting suitable for E14 / E27 / B22 lamp holders, pf >= 0.5**

**(A) LED Lamps integral type, with PC diffuser suitable LAMP holder**

**(iii) 10 to 15 watts Cat III**

The relevant specifications of Description item No.129 shall be followed.

**Item No. 131**

**Supplying and erecting LED street light / Flood light fittings with High power White LEDs wattage of 3 Watt and above assembled on single MCPCB, efficiency more than 130 lm/w and corrosion free High pressure die cast aluminum housing with smooth finish powder coated and heat sink extruded aluminium with diffuser and Polycarbonate optics/ lenses, with toughened glass with company mark/name engraved or embossed 160 to 270 V, Power Factor more than 0.95, THD < 10 %, CCT 3000 K to 5700K, Uniformity ratio >0.45, Luminaire efficacy > 100 lumens/watt . LED driver efficiency > 85 %.( fittings required LM-79 & LM-80 certificates)(NOTE: Below description have shown ranges of Wattage capacity of LED fittings.The Engineer incharge may select any wattage capacity between the ranges shown.)**

**(A) Street Light (IP-65), Surge protection -4KV integral and ,Light must have 440VAC line supply with over-voltage protection.**

**(iv) above 90 to 120 watts**

SITC OF LED LIGHT LUMINAIRES:-

TECHNICAL SPECIFICATION FOR ENERGY EFFICIENT LED BASED LUMINAIRE UNIT FOR LED LIGHT: -

This specification is for technical and general requirements design, development, manufacturing, testing and supply of energy efficient LED luminary complete with all accessories, LED lamps with suitable current control driver circuit and required optics including mounting arrangement.

CODES & STANDARDS: -

IEC 60529 Classification of degree of protections provided by enclosures (IP Codes)

EN 55015, CISPR15 Limits and methods of measurement of radio disturbance characteristic of electrical lighting and similar equipment.

IEC 62031 LED modules for general lighting-Safety requirements

IEC 61547-EMC Immunity requirement

IEC 60598-2-1 Fixed general purpose luminaires

IEC 60598-1 Luminaires - General requirement and tests

IEC 61000-3-2 Electro Magnetic compatibility (EMC)- Limits for Harmonic current emission — (equipment input current ≤ 16 A per phase.

IEC 60068-2-38 Environmental Testing: Test Z- AD: composite temperature/ humidity cyclic test

IEC 61347-2-13 Lamp control gear: particular requirements for DC or AC supplied electronic control gear for LED modules.

IS 10322 Specification for the luminaries

IS 4905 Method for random sampling

LM 79 LED luminary photometry measurement.

LM 80 Lumen Maintenance

IEC 62384 DC or AC supplied electronic control gear for LED modules performance requirements

IEC/ PAS 62612 Self-ballasted LED lamps for general lighting services- Performance requirements

CONSTRUCTIONAL FEATURES:

General:

a) Luminaries shall be made of die cast aluminium/ extruded Aluminium body with powder coated finish having safety.

b) Heat sink used should be aluminium extrusion having high conductivity. Heat sink should be integrated within luminaries and efforts shall be made to keep the overall outer dimensions

c) optimum such that it permits sufficient heat dissipation through the body itself so as to prevent abnormal temperature inside the luminaries and consequential damage to cover, gasket material, LEDs, lenses and drivers.

d) LED must be mounted on Metal core PCB with suitable large area surface by means of fins to dissipate the conduct heat. The fins must be exposed to ambient flowing air.

e) All luminaries shall be provided with toughened glass of min. 0.8 mm thickness of sufficient strength. UV stabilized Poly carbonate material is also acceptable. High efficiency prismatic diffuser/Lens under the LED chamber to protect the LED and luminaries shall be provided.

f) The minimum IK protection of optic cover shall be IK 05. The test material certificate shall be provided.

g) Suitable number of LED lamps shall be used in the luminaries. The manufacturer shall submit the proof of procurement of LEDs from OEMs at the time of testing.

h) Suitable reflector/ lenses may also be provided to increase the illumination uniformity and distribution.

i) The electrical component of the LED and LED driver must be suitably enclosed in sealed unit to function in environment conditions mentioned earlier. j) The connecting wires used inside the luminaries, shall be

low smoke halogen free, fire retardant e-beam cable and fuse protection shall be provided in input side.

k) Design of the thermal management shall be done in such a way that it shall not affect the properties of the diffuser.

l) The equipment should be compliant to IEC 60598-1, IEC 62031 and IEC/PAS 62612 depending on the type of luminary. m) The LED Module(s), Driver gear, etc. shall be designed in such a way so that temperature of heat sink shall not exceed 70° C. n) All the material used in the luminaries shall be halogen free and fire retardant confirming to standard. o) The infrastructure for Quality Assurance facilities to verify/ test/ prove

above specifications must be available at the manufacturing facility. The compliance shall be indicated clearly in the tender itself.

p) All fasteners must be of stainless steel.

q) All glands inside/ outside luminaries must be metallic

r) Heat sink must be thermally connected to MCPCB/ LED light source.

High power and high lumen efficient LEDs suitable for following features shall be used:

a) The working life of the lamp at junction temperature of 85° C (max) at operating current shall be more than 50,000 working hours of accumulative operation and shall be suitable for continuous operation of 24 hours per day. These features shall be supported with datasheet.

b) Adequate heat sink with proper thermal management shall be provided.

c) Lumen maintenance report as per LM 80 guidelines shall be produced for the power LEDs used.

d) Thermal management shall be in such a way that LED soldering point temperature shall not go beyond 75° C.

e) The LED luminaries shall be free of glare.

LED DRIVER specification:

a) Current waveform should meet relevant nation and international standard.

b) LED Driver shall withstand, withstand voltage up to level mentioned elsewhere in tender and restore once normal working when normal voltage is applied.

c) The life of the driver should more than 25000 Hrs.

d) Maximum Temperature rise  $\leq 30^{\circ} \text{C}$  @  $45^{\circ} \text{C}$  Tamb. With safety margin of  $10^{\circ} \text{C}$ .

e) The control gear should be compliant to IEC 61347-2-13, IEC 62031 and IEC 62384 as per the requirements.

f) The driver of the luminaries should have Short Circuit, Over Voltage, over current, over temperature, Under Voltage, String Open protections.

The electronic components used shall be as follows:- a) The protective cum adhesive coating used on PCBs should be cleared and transparent and should not affect colour code of electronic components or the product code of the company. b) The construction of PCBs and the assembly for components for PCBs should be as per IS standards.

Illumination Level:

The luminaries shall be so designed that the illumination level shall be evenly distributed and shall be free from glare. The lux distribution curve/ graph/ spatial distribution shall be submitted.

#### GENERAL DATA SHEET

Parameter Value & Detail

- Rated Supply Voltage 230 V ~, 50 Hz
- Input supply voltage range 120-270 V
- Expected Input Frequency 50 Hz +/- 3%
- Working Temperature  $+5^{\circ}$  to  $+50^{\circ} \text{C}$
- Working Humidity 10% - 90% RH
- Usage hours Dusk to dawn
- Power Factor  $\geq 0.90$
- Index of Protection Level IP 66 as per IEC 60529.
- Surge Protection 4 KV
- LED Chip efficacy  $\geq 120 \text{ lm/ W}$
- Driver Efficiency  $> 85\%$
- Junction Temperature of LED  $< 85^{\circ} \text{C}$
- Rated Life @ L70 50,000 burning hours at  $35^{\circ} \text{C}$  ambient
- Nominal Correlated Colour Temperature  $5000^{\circ} \text{K}$  to  $6000^{\circ} \text{K}$
- Dispersion Angle Minimum  $120^{\circ}$
- Tilting angle Adjustable
- Maintenance factor of 0.85
- Colour Rendering Index  $\geq 75$
- Total Harmonic Distortion  $< 10\%$  (EMI/ EMC Certification)
- LED MAKE Cree/ Osram/ Nichia/ Philips Limited's

Particulars and Details to be submitted by the bidder:

In order to properly assess and due diligence on submissions, the Bidder should provide following information on the quality and photometric of proposed luminaries.

1. General Description

Following details of the proposed luminary shall be submitted

2. Electrical specifications

Electrical ratings of the proposed luminary product shall be submitted

3. LED chip and driver information

LED chip and driver information of the proposed luminary product shall be submitted

4. Photometric information to be submitted TESTS & CERTIFICATES:

Tests are classified as:-

Type test Acceptance test

Routine test.

The luminaries' should be tested as per IEC 60598-2-3: 2002 standards and following test reports should be submitted: -

(i) Heat Resistance Test

(ii) Thermal In SITU Test

(iii) Ingress Protection Test

(iv) Drop Test

(v) Electrical/ Insulation Resistance Test,

(vi) Endurance Test,

(vii) Humidity Test,

(viii) Electrical and Photometric Measurements Test Report (IES LM 79)

(ix) LED Lumen Maintenance Test Report (IES LM 80)

(x) Vibration test as per ANSI

Type Test: -

Type test certificates for both the luminaries' shall be provided with the technical-bid.

Acceptance Tests: -

These tests are carried out by an inspecting authority at the supplier's premises on sample taken from a lot for the purpose of acceptance of a lot. Acceptance tests shall not be carried out from particular size from the lot on which type tests have already been conducted. Recommended sampling plan is given below.

Sample size and criteria for conformity

The luminaries shall be selected from the lot at random. In order to ensure randomness of selection, procedures given in IS 4905-1968 (Reaffirmed 2001) may be followed.

Routine Tests:

These tests shall be performed by the manufacturer on each complete unit of the same type and the results shall be submitted to the inspecting agency, prior to offering the lot for acceptance test. The firm shall maintain the records with traceability.

Test Scheme & Quality Assurance

Method of Testing: -

Visual and Dimensional Check:

The unit shall be checked visually for all dimensions as per approved design and drawing.

General workmanship should be good; all the components properly secured and sharp edges shall be rounded off. Check the marking and quality of the workmanship visually. Check the rating and make of electronic/ electrical items.

Checking of documents of purchase of LED

Check Document of purchase of LED lamps of approved sources viz. NICHIA/ OSRAM/ PHILIPS LUMILEDS/ CREE.

**Resistance to humidity test**

This is carried out by suspending the painted panels in corrosion chamber maintained at 100% RH and temperature cycle of 42 to 48° C for 7 days and examining it for any sign of deterioration and corrosion of metal surface.

**Insulation resistance test**

The insulation resistance of the unit between earth and current carrying parts shorted together shall not be less than 2 MΩ when measured with 500 V megger.

**HV test**

Immediately after insulation resistance test, an AC voltage of 1.72 KV rms (1500 + 2 x rated voltage) of sine wave form of 50 Hz shall be applied for one minute between the live parts and frame. There shall not be any kind of break down, flashover or tripping of supply.

**Over voltage protection**

The LED Driver Shall be cut off once voltage exceeds 288 V AC. It shall be reconnected when supply comes within limit.

**Surge protection**

It shall withstand a surge of 4 KV at the input terminals for all types.

**Reverse polarity**

The Luminaries' shall withstand polarity reversal. It shall be operated with reverse voltage for Min. 1 minute at maximum value of voltage range. At the end of this period, the supply shall be made correct polarity and Luminary shall operate in a normal way.

**Temperature rise Test:**

Temperature rise Test shall be conducted at 100 V ~ with full load. The temperature rise shall be recorded by temperature detectors mounted at the specified reference points on the body of semiconductors, capacitors and other components as agreed between purchaser and manufacturer. The maximum-recorded temperature under worst conditions shall be corrected to 55° C and compared with maximum permissible temperature (for power devices at junction). Under loading conditions as specified above, the corrected temperature of the power devices shall have a safety margin of minimum 10° C.

Temperature at junction shall not exceed 100° C when corrected to 55° C. The Luminaries' shall also be subjected for short time rating after continuous loading to

ensure the temperature rise is within the permissible limit. The maximum temperature rise of the electronics devices on the PCBs shall be in limit for industrial grade components suitable for 85° C environment. In case of exceeding limit, use of MIL-grade component shall be considered keeping RDSO informed.

**Ra (Colour Rendering Index) measurement test**

The lumen is the unit of luminous flux, which is equal to the flux emitted in a solid angle of one steradian by a uniform point source of one candela.

The initial reading of the chromaticity co-ordinates x & y shall be within 5 SDCM (Standards Deviation for Colour matching) from the standardised rated value as per Annex: D of IEC 60081- 1997.

The initial reading of the general colour-rendering index (Ra) shall not be less than the rated value decreased by 3.

The lumen maintenance of the lamp shall not be less than 80% of the initial lumen after 20,000 burning hours and 70% of the initial lumen after 50,000 hours. The initial lumen will be taken after 100 hours aging.

Photometric test shall be conducted as per Annexure: B of IEC 60081-97.

The lumen maintenance test shall be done as per Annexure: C of IEC 60081-97.

**Fire retardant Test**

Fire Retardant test shall be conducted as per IEC 60332-1 of the wire used in the luminaries.

Test for IP 65 protection

This test shall be conducted as per IEC 60529.

Environmental tests (Proto type Test)

The Luminaire shall meet the following tests as prescribed in IEC-60571.

- (i) Dry heat test.
- (ii) Damp heat test
- (iii) Test in corrosive atmosphere
- (iv) Combined dust, humidity and heat test

Reliability Test

The reliability can only be determined in actual service. However, the following tests shall be carried out on the prototype to simulate as close as possible, the service conditions.

There shall be no failure during this test.

- (i) The light unit shall be mounted in an oven maintained at 45° C.
- (ii) The light will be operated at the specified maximum voltage and at 45° C for a period of 100 hours.

Photometry Test: -

The test shall be carried out for Total Luminous Flux, Luminous Intensity Distribution, Electrical Power, Luminous Efficacy (calculation), Color Characteristics- Chromaticity, CCT & CRI etc. as per IES LM 79.

Life Test

The lumen maintenance & life test shall be done as per IES LM 80 for LEDs.

Endurance Test

The Luminaire shall be kept "ON" with input voltage of 250 V ~ for 200 hours. After this the Luminaire is subjected to 20,000 cycles of "ON" and "OFF", each cycle consisting of 3 seconds "ON" and 10 seconds "OFF" period. Luminaire should survive this test. Test is to be continued for 20,000 cycles, followed by performance test.

Safety:

The Luminaire shall comply with the safety requirements as per IEC 61195.

All Tests defined for acceptance other than LM 79 and LM 80 are allowed to carry out at Manufacturer works.

#### 4. INFRINGEMENT OF PATENT RIGHTS

Client shall not be responsible for infringement of patent rights arising due to similarity in design, manufacturing process, use of the components, used in design, development and manufacturing of these light luminaires and any other factor which may cause such dispute. The responsibility to settle any issue rises with the manufacturer.

#### 5. MARKING:

The following information shall be distinctly and indelibly marked on the housing:

Year of manufacture/ Batch Number/ Serial Number

Name of Manufacturer (Engraving only, stickers not allowed)

Rated watt and voltage

Input frequency

#### 6. METHOD OF MEASUREMENT

Supply of the fixture including transport to site, loading and unloading etc. as specified will be treated as one unit for measurement and payment.

#### 7. TRANSPORT, DELIVERY AND STORAGE



The prices shall be F.O.R. site basis including packing & forwarding charges. The quoted price must include all the costs for necessary mode of transportation up to the final location of fixture or site store. The fixture should be supplied with required storage arrangements suitable for placing in open storage yard. All incidental expenses during transportation shall be part of quoted prices including transit insurance. The charges for loading and unloading of equipment at site should form part of offer.

#### 8. GUARANTEE AND WARRENTY

The Bidder shall stand guarantee for the performance of entire fixtures and components for twenty four (24) months from the date of commissioning or from issuance date of completion certificate, whichever is earlier, as agreed upon and as reproduced in the purchase order within the tolerance specified or as permitted by the relevant standards for the equipment in his scope of supply. The Purchaser also reserves the right to use the rejected equipment or part thereof until the new equipment meeting the guaranteed performance is supplied by the Bidder.

#### 9. SPARES

The bidder shall quote for minimum spares required for two years safe operation of light fixtures along with the offer separately.

#### **Item No. 132**

**Supplying and erecting Flexible PVC insulated multi strand multi core 1.1 kv grade ISI marked copper wires of following size to be erected as directed.**

**(e) 1.50 Sq.mm 3 core round PVC sheathed**

The relevant specifications of Description item No.120 shall be followed.

#### **Item No. 133**

**Providing and erecting Sheet Steel powder coated MCB distribution board - flush / surface mounted fitted with busbar, neutral link, earth bar and DIN rail, Conforms to IS 8623-1 & 3, IEC 61439-1 & 3 without MCB to house appropriate nos. of MCBs.(The DBs should be used of same company of MCB to be used) suitable for**

**(A) single phase incoming and horizontal single phase outgoing**

**(b) sheet steel double door (IP-43)**

**(iv)12 way**

Distribution Boards (DB's) shall be suitable for operation on 3 Phase/single phase, 415/240 volts, 50 cycles, neutral grounded at transformer. The DB shall be minimum dielectric strength of 2.5 KV / Sec. All Distribution Boards shall manufactured by a manufacturer listed in Appendix-I.

DB's shall comply with the latest Relevant Indian Standards and Electricity Rules and Regulations and shall be as per IS-8623-1977 (Part-1).

#### **CONSTRUCTION FEATURES :**

DB's shall be IP 43& made out of high quality CRCA sheet steel and shall be pre-treated and powder coated sheet steel used in the construction of DB shall be folded and braced as necessary to provide a rigid support for all component. DB shall be suitable for indoor / outdoor installation, wall mounting free standing type, in double door construction. The Distribution Boards shall be totally enclosed, completely dust and vermin proof and shall be with hinged doors, padlocking arrangement. All removable/ hinged doors and covers shall be grounded by tinned stranded copper connectors. Distribution Boards shall be suitable for the climatic conditions. Joints of any kind in sheet metal shall be seam welded, all welding, slag shall be rounded off and welding pits wiped smooth with plumber metal. The general construction shall confirm to IS-8623-1977 (Part-1) for factory built assembled switchgear & control gear for voltage up to and including 1100 V AC.

All panels and covers shall be properly fitted and square with the frame, and holes in the panel correctly positioned. Fixing screws shall enter into holes tapped into an adequate thickness of metal or provided with wing nuts. Self threading screws shall not be used in the construction of DBs. Three phase boards shall have phase barriers and a wire channel on three sides. Neutral bars shall be solid tinned copper insulated bars with tapped holes and chase headed screws. For 3 phase DB's, 3. Independent neutral insulated bars shall be provided. All DB's shall be internally pre-wired using copper insulated PVC wires brought to a terminal strip of appropriate rating for outgoing feeders. Knockout holes of appropriate size and number shall be provided in the DB's in conformity with the location of cable/conduit connections. Detachable sheet steel gland plates shall be provided at the top / bottom to make holes for additional cable entry at site if required.

**Distribution Boards shall comprise of the following:**

A panel for mounting where appropriate incoming supply circuit breaker & other auxiliaries for Control & distribution as required.

Installation accessories shall be part of the DB for fixing conductor and rails for mounting MCB's and RCCB's etc.. neutral bus bars & earthing bus bars required in the circuit. All busbars in the FDB shall be insulated type.

Service cable /interconnection shall be part of the Distribution Boards.

The board shall be installed at a height such that the operating is within reach of the normal human height i.e. 1.2 to 1.8 meters from finish floor level.

Phase segregation to be maintained in all three phase distribution boards.

Earthing shall be provided in each FDB's.

**Item No. 134**

**(B) three phase incoming and single phase horizontal type outgoing Per phase isolation type (PPI)**

**(b) sheet steel double door (v) 16 way**

The relevant specifications of Description item No.133 shall be followed.

**Item No. 135**

**providing and erecting Miniature circuit breaker single pole 6A to 25A suitable to operate on 240 V A.C. system and having breaking capacity 10 KA to be erected in existing box. confirming to IS 8828/1996 with ISI Mark**

**Cat. III**

**MCB**

Miniature Circuit Breaker shall comply with IS-8828-1996/IEC898-1995. Miniature circuit breakers shall be quick make and break type for 240/415 VAC 50 Hz application with magnetic thermal release for over current and short circuit protection. The breaking capacity shall not be less than 10 KA at 415 VAC. MCBs shall be DIN mounted. The MCB shall be Current Limiting type (Class-3). MCBs shall be classified (B,C,D ref IS standard) as per their Tripping Characteristic curves defined by the manufacturer. MCB shall ensure complete electrical isolation & downstream circuit or equipment when the MCB is switched OFF.

The housing shall be heat resistant and having a high impact strength. The terminals shall be protected against finger contact to IP20 Degree of protection. All DP, TP, TPN and 4 Pole miniature circuit breakers shall have a common trip bar independent to the external operating handle.

MCB should be having an integrated label holder with dual side din rail locking facility. Incoming & Outgoing should have facility for termination of Busbar & Cable separately. Cable termination facility should be up to 35 sq. mm.

**Item No. 136**

Supplying & erecting earth pit of minimum bore dia.150mm size approved make Earthing Electrode consisting Pipe-in-Pipe Technology as per IS 3043-1987 made of corrosion free hot dipped G.I.Pipes having Outer pipe dia of 50mm having 80-200 Micron galvanising, Inner pipe dia of 25 mm having 200-250 Micron galvanising, connection terminal dia of 12mm with constant ohmic value surrounded by highly conductive compound with high charge dissipation suitable for following type of applications with chamber and heavy duty cover.(approved make OEM has to submit test certificate) & having back filling compound of (B) Inner chemical (CCM Compound)- Resistivity:- 0.2  $\Omega$ / meter testing as per IEC 62561-2017, Voltage drop:- < 1 volt at no load & dry form, Sulphar content:- <2%(C) Back fill Compound :- Earthing compound should be capable to retain moisture for long time Necessary test report must be submitted.

**(b)For Electrical installation up to 11 KV in normal soil.**

**Length of Pipe : 2.00 mtrs**

**Back filling Compound :1 No. Bag of 25 Kg..**

**General:**

All the non-current carrying metal parts of the electrical installation and mechanical equipment shall be earthed properly. The cables Armored and sheath, electric panel boards, lighting fixtures, ceiling and exhaust fan and all other parts made of metal shall be bonded together and connected by means of specific earthing system. An earth continuity conductor shall be installed with all the feeders and circuit shall be connected from the earth bar of the panel boards to the conduit system, earth stud of the switch box, lighting fixtures, earth pin of the socket outlets and to any metallic wall plates used. All the enclosures of the motors shall be also connected to the earthing system.

**Scope Of Work:**

The scope of work shall cover supply, laying, installation, connecting, testing and commissioning of : Earthing station. Earthing G.I./Copper strips from earthing station to equipotential bar. Earthing G.I./Copper strips/ wires from equipotential bar to lay feeder mains and circuit to connect power panels, DBs, switchboards, motors, etc. Bonding of Non-current carrying parts, and metallic parts of the electrical installation.

**Standards:**

The following standards and the rules shall be applicable.

- 1) IS; 3043 – 1966 Code of practice for earthing.
- 2) Indian Electricity Act and Rules

All codes and standards mean the latest. Where not specified otherwise the installation shall generally follow the Indian Standard Code of Practice or the British Standard Code of Practice in absence of Indian standards.

**Type of Earthing Station:**

**Plate Earthing Station:**

The equipment neutral earthing shall be with copper plate earthing station and equipment body earthing shall be with hot dip galvanized iron earthing station.

The plate electrode shall be 600 x 600 x 3.25 mm copper plate for neutral earthing and shall be of hot dip galvanized iron plate having dimension 600 x 600 x 6.3 mm thick for body earthing.

The earthing station shall be as shown in the drawing. The earth resistance shall be maintained with suitable soil treatment as shown in the drawing. The resistance of each earth station should not exceed 1 ohm. The earth lead shall be connected to the earth plate through Hot Dip G.I bolts. The earthing conductors shall be of copper strip in case of copper earthing and hot dip galvanized iron strip in case of G.I earthing. G.I pipe with funnel of approved quality shall be used for watering the earthing electrodes/station. The block masonry chamber with chequered plate shall be provided for hosing the funnel and the pipe for watering

the earthing electrodes/ station. The hardware and other consumable for earthing installation shall be of copper/brass in case of G.I earthing.

**The link/test pit covers through chequered plate.**

Installation And Connection:

The plate / pipe electrode, as far as practicable, shall be buried below permanent moisture level but in no case less than 3Mtr below finished ground level. The plate / pipe electrode shall be kept clear of the building foundation and in no case, it shall be neared by less than 2Mtr from outer face of the respective building wall /column. The plate electrode shall be installed vertically and shall be surrounded with 150 mm thick layers of charcoal dust and salt mixture.20 mm dia. G.I. pipe for watering shall run from top edge of the plate / pipe electrode to the mid level of block masonry chamber. Top of the pipe shall be provided with G.I. funnel and screen for watering the earth /ground through the pipe. The funnel with screen over the G.I. pipe for watering to the earth shall be housed in a block masonry chamber as shown in the drawing. The masonry chamber shall be provide with a cast iron hinged cover resting over the cast iron frame which shall be embedded in the block masonry Contraction of the earthing station shall bin general be as shown in the drawing and shall conform to the requirement on the earth electrodes mentioned in the latest edition of Indian standard IS: 3043, Code of Practice for Earthing installation. The earth conductor (Strips / wires, G.I. / copper) inside the building shall properly be clamped / supported on the wall with Galvanized iron clamps and hot dip GI screws / bolts. The conductor outside the building shall be laid at least 600 mm. below the finished ground level.

The earth conductor shall either terminate on earthing socket provide on the equipment or shall be fastened to the foundation bolt and /or on frames of the equipment. The earthing connection to equipment body shall be done after removing paint and other oily substance from the body and then properly be finished. Over lapping of earth conductor during straight through in joints, where required, shall be of minimum 75 mm. long. The earth conductor shall be in one length between the earthing grid and equipment to be earthed.

**Earth Leads And Connection:**

Earth lead shall be bare copper or galvanized steel as specified with sizes shown on drawings. Copper lead shall have a phosphor content of over 0.15% . Galvanized steel buried in the ground shall be protected with bitumen and Hessian wrap or polythene faced Hessian and bitumen coating. At road crossing necessary Hume pipes shall be laid. Earth lead run on surface of wall or ceiling shall be fixed on saddles so that strip is at least 8 mm away from the wall surface. The complete earthing system shall be mechanically and electrically bonded to provide an independent return path to the earth source. Wherever crossing is required, earth jumper shall be of insulated wires.

**Equipment Earthing**

All apparatus and equipment transmitting or utilizing power shall be earthed in the following manner. Copper / G.I. earth strips /wires shall be used unless other-wise indicated in the BOQ.

**Power Transmission Apparatus:**

Metallic conduit shall not be accepted as earth continuity conductor. A separate insulated continuity conductor of size 100% of the phase conductor subject to the minimum shall be provided.

NOMINAL CROSS-SECTIONAL AREA OF LARGEST ASSOCIATED COPPER CIRCUIT CONDUCTOR SQ. MM  
 NOMINAL CROSS-SECTIONAL AREA OF EARTH-CONTINUTY CONDUCTOR SQ. MM

2.5 2.5

4 4

6 6

The earth continuity conductor be drawn inside the conduit shall be insulated.

Nor metallic conduit shall have an insulated earth continuity conductor of the same size for metallic conduit. All metal junction and switch boxes shall have an inside earth stud to which the earth conductor shall be connected. The earth conductor shall be distinctly colour (green or green / yellow) for easy

identification. Armoured cable shall be earthed by two distinct earth connections to the armoring at both the ends and the size of connection being as for the metallic conduit. In the case of unarmored cable, an earth continuity conductor shall either be run outside along with the cable or should from a separator insulated core of the cable. Three phase power panel and distribution boards shall have two distinct earth connections of the size correlated to the incoming cable size. In case of single phase of DB's a single earth connection is adequate.

**Test:**

The entire earthing installation shall be tested as per requirement of Indian Standard Specification IS:3043. The following earth resistance values shall be measured with an approved earth megger and record.

Each earthing Station

Earthing system as a whole

Earth continuity conductors

Earth conductor resistance for each earthed equipment shall be measured which shall not exceed 1 ohm in each case. Measurements of earth resistance shall be carried out before earth connections are made between the earth and the object to be earthed. All test shall be carried out in presence of the consultant/client.

**EARTHING STRIPS:**

Supply, erection, testing and commissioning of earthing strips for connection between LT switch gear, motor, starter as well as transformer neutral and earthing stations. The earthing strips shall be laid underground or in trenches or on the floor of pump house and hence excavation/ refilling, clamps etc shall be included. The strips shall be finally painted with green colour. The joints shall either be brazed or bolted after tin plating the ends and using GI/brass bolt nut and washers as per direction of engineer –In- charge. All equipment earthing joints must be done using nut-bolts and other must be welded. For measurement purpose over lapping of joints shall not be considered and payment shall be made as per actual basis. All necessary excavation, refilling shall be in the scope of the work. Two separate and distinct earth leads shall be used for earthing each equipment/structures enclosing the power conductor and one earth lead for metallic structure adjacent to electrical installation. Metallic frames of all electrical equipment rated above 250 volts, must be earthed by two distinct connections with earth system. Earthing cables crossing other metallic structures such as conduits pipe lines etc., shall be minimum 300 mm away from such structures. All underground connections and joints in earthing system shall be brasses/welded. Connections with equipments/structures shall be bolted type. Conducting petroleum jelly shall be applied to contact surfaces of all bolted joints and joints shall be covered with bituminous compound and taped. When G.I. conductors are connected to aluminum conductors the contact surfaces of G.I. shall be tinned to prevent bimetallic corrosion. Neutral connection shall never be used for the equipment earthing. Earthing conductors shall be protected against mechanical damage.

All motors can be connected to the earth grid by providing pads. Earthing conductors running along the structures, wall etc. shall be cleated at every 750 mm interval. Minimum size of earth conductor shall be in accordance with IS:3043. However, sizes of earth conductors for equipment shall be at least half the size of power conductor, limited to maximum of 120 mm of aluminium. All earth lead connections shall be as short and direct as possible and shall be without link Method Of Measurement: Provision of earthing station complete with excavation, electrode, watering pipe, soil treatment, masonry chamber with cast iron cover etc. shall be treated as one unit of measurement.

The following items of work shall be included in the cost of earth stations. wires / strips, clamps, labour etc.

- i) Main equipment earthing grid and connection to the earthing station.
- j) Connection to the switch board, power panels, DB etc.

The cost of earthing the following items shall become part of the cost of the item itself and no separate payment for earthing shall be made.

- a) Motors- earthing forming part of the cabling/wiring for the motors.

- b) Isolating switches and starters should form part of mounting frame, switch starter etc.
- c) Light fitting- form part of installation of the light fittings.
- d) Conduit wiring, cabling- should form part of the wiring or cabling.
- e) Street lighting- should form part of the street light poles.

**Item No. 137****Providing and erecting HOT deep Galvanised iron strip wire 8 to 16 SWG.**

- Supply, erection, testing and commissioning of earthing strips for connection between LT switch gear, motor, starter as well as transformer neutral and earthing stations
- The earthing strips shall be laid underground or in trenches or on the floor of pump house and hence excavation/ refilling, clamps etc shall be included.
- The strips shall be finally painted with green colour. The joints shall either be brazed or bolted after tin plating the ends and using GI/brass bolt nut and washers as per direction of engineer –In- charge.
- All equipment earthing joints must be done using nut-bolts and other must be welded. For measurement purpose over lapping of joints shall not be considered and payment shall be made as per actual basis.

All necessary excavation, refilling shall be in the scope of the work.

**Item No. 138****Supplying & erecting single phase approved make industrial exhaust fan suitable for medium duty ring mounted low noise operation suitable for medium duty having following dia size and maximum speed in RPM****[A] 305 mm dia 900 RPM Cat. II**

This work includes the connections of 2 core 1.5 mm<sup>2</sup> PVC insulated wires and earth wire from 5 A PVC/Bakelite connector of fan / exhaust fan point to connector of fan / exhaust fan, connectors, fixing of fan in hook provided in the box, making exhaust fan opening in walls including repair / finishing of opening and fixing of exhaust fan complete with accessories and louvers on walls with hold-fasts, testing the fan / exhaust fans and commissioning.

**Item No. 139**

**Supply, installation, testing & commissioning single girder type fully electrically operated EOT crane with electrically operated hoist, class II duty, geared travelling trolley with seven meter lift complete with long travel rail track (40 mm sq. bar), moving or cross girder, all three motions electrically operated by suitable rating motor IP 54, control panel & down pendant control block, brake, safety device, cables form motor to starter panel & other required accessories & tested as per IS Specifications.**

**Capacity 3 ton, span 9m - 12m, Lifting 6m - 10m and long travel 20 m**

**GENERAL DESIGN REQUIREMENTS**

All mechanical equipment shall be simple robust design, easy for erection, inspection, adjustment painting dismantling. Fastenings shall be to hold the parts in place under all specification conditions of service. Steel castings, steel forged wrought steel wheels sheaves shall be anchored properly. All shaft loads shall be transmitted through suitable keys, splices or pins not by press. Wherever practicable, machinery shall be mounted on self-supporting steel frames or bedplates or on structural steel supports. All working parts

shall be accessible for servicing. The crane travel shall be by hoist shall be motor driven. The capacity of lift as per design of pumping station.

The crane shall be guaranteed by the manufacturer of accepted modern design free from inherent design in either workmanship or materials; to safely fully hold its rated load without any deflection in its structure or mechanism. All material shall be the best of their kinds. Any part proved defective within one year from date of erection testing at site shall be replaced free of charge by supplier.

#### **CRANESTRUCTURE**

The crane structure shall conform to IS: 807 latest edition shall be designed to withstand stresses arising from simultaneous travel of the rated load of the crane along the bridge the travel along the track to withstand the effect any Possible combination of forces due to the loads, live loads, local bending, inertia force, earthquake in the area as specified, with adequate factor of safety. The bridge structure of the crane shall be of single girder construction to safely carry full rated load of the crane without undue vertical or lateral deflection or vibration. Girder shall be connected to the top side of each truck in such a manner that skewing will be prevented. The trolley supporting rails shall be laid on top of bridge steel rail stops shall be provided at end of the bridge. Trolley stops should be spring type to reduce shock impact on the structure. All joints in the tension zone of the girder shall be radio graphically tested test certificate furnished for approval before dispatch of the crane.

Each bridge end truck (crane has two end trucks) shall consist of two channels connected to from a ring box section. Trucks shall be so designed that the loading is equally distributed to each channel.

#### **TROLLEY**

Trolley shall consist of a welded frame of structural steel sections adequately braced to resist vertical, lateral torsion strains, properly machined to receive the hoisting drums, wheels, axles etc. All the mechanical equipment shall be mounted on machined pads. These pads shall be permanently welded to the supporting structures after final alignments. Trolley frame shall be provided with safety stops, jacking pads, equipment covers railing as required. The trolley wheel bearings shall have heavy-duty roller bearings antifriction type. Wherever bearing caps are provided they shall be provided with fittings for adequate lubrication. On the bottom of the trolley frame, on each side, a double end spring bumper shall be provided to engage stops at each end of the bridge.

#### **WHEEL AXLES**

Wheel axles shall be stationary type made from steel ground to size to receive the inner race of the roller bearings. Axles shall be prevented from turning or working endwise by means of a key plate fitting into a milled slot in the end of the axle bolted to the end trucks. Wheels shall generally conform to IS: 3177.

Wheel shall be double flanged type for end trucks. They shall be accurately machined to suit the rail on which they are to operate. Axles and shafts shall be made of high strength low alloy steel.

All bearings shall be of antifriction type of adequate capacity. Due allowance shall be made for impact side thrusts. Truck trolley wheels shall be provided with roller bearings. Other bearings may be ball bearings. Bearings shall be made of steel.

All gears shall conform to relevant Indian Standard also to IS: 3177 straight spur helical gears shall normally be used for all motions. Gear boxes shall generally conform to IS: 3177. Gear shall be cut from forged steel blanks.

Adequate provision shall be made for proper lubrication of all gears, bearings pulley. Bearings shall be designed for grease lubrication of all gears, bearings pulley. Bearings shall be designed for gear lubrication by grease gun.

Each trolley shall move over the inside of the bottom flange of the I-beam. The gear pulley assembly should be so located that there is no fouling with the bridge drive pulley shaft. The trolley shall be spur gear type.

#### **RUNWAYRAILS**

The contractor along with the crane shall furnish suitable runway rails of adequate size. The erection of runway rails is also included in Contractor's scope. The runway lengths of the rails will be as indicated in the Technical Data Sheets. However, these lengths are tentative only the actual length of rails will be determined at a later date depending on the final dimensions of the building. Bridge stops will be provided at each end of the rails. The contractor shall provide all clamps fittings necessary for fixing the rails.

#### **LADDERS**

The contractor shall be provided with necessary access from operating floor to gantry girder level.

#### **ELECTRICALLY OPERATEDHOIST**

#### **DESIGNREQUIREMENTS**

- Electric hoists shall be complete with hoisting motor, wire rope drum, wire rope, hook necessary gearing, sheaves electromagnetic brakes for hoisting. Weather dust- proof push button station, connector panel creep speed arrangement all wiring,
- Flexible trailing cable, limit switches, travel stops, ear-thing terminals other accessories to meet the full requirements of the Engineer-In-Charge. The Engineer- In-Charge will provide electric supply at one point in pump house.
- The hoist will be required to operate in the local climatic conditions. All the parts of the hoist trolley



shall be designed to withstand such atmospheric conditions without any deterioration.

### **FEATURES OF CONSTRUCTION**

All though, this is an EOT crane, there shall be an optional provision of manually operating through a chain drive, from the pump-house floor. The hoist shall have the following requirements:

#### **DRUMS**

Rope drums shall be MS seamless type, as per ASTM 106, Gr. B made out of tested quality of plates. Drums shall be machine grooved right left with grooves of a proper shape for the rope used. Grooving shall be of proper length to held all rope needed to make the required lift plus the two dead laps at each anchor point, without overlapping. Drum shall be flanged at both the ends. Flanges shall project above the rope by a distance not less than two-rope diameter.

#### **SHEAVES**

Rope sheaves shall be rolled steel. Grooves shall be machined to the proper shape for the rope used. Sheaves shall be equipped with anti-friction type bearings. Sheaves shall be fully guarded so that the rope cannot come off.

#### **GEARS**

Gears shall be from solid forged steel blanks or shall be of stress-relieved welded steel construction or built-up from steel billets welded together to form a one- piece gear section.

#### **BEARINGS**

All anti-friction bearings are to be of Standard make and interchangeable with corresponding other Standard sizes of the bearings. Bearings shall have a minimum life expectancy of 40,000 hours may be ball, roller, or removable bronze-bushing type except that motor bearings shall be of the ball or roller type.

#### **ROTATING STATIONARY SHAFTS**

Shafts axles shall have ample strength rigidity adequate bearing surfaces for their duties.

#### **LUBRICATION**

A centralized grease lubrication unit with h operated grease pump shall be provided for anti-friction bearings.

#### **HOIST ROPE**

Hoist ropes shall be extra flexible, improved plough steel rope with a well lubricated hemp core having six str of 37 wires per str with an ultimate tensile strength of 160/175 kg/sq. mm. The rope shall be fastened to the drum with an attachment having strength equal to that of the rope. The rope shall be of sufficient length so that two full laps shall remain on the drum at the extreme low position of the hook. Reverse bends or cross bends are to be avoided. The breaking loads for the hoist ropes shall not be less than six times the calculated load in the ropes at the drum, based on rated load on hooks, plus the weight of the

bottom block, plus the weight of rope. Wire slings with U-bolts (2 nos.) shall be supplied with the hoist hook.

#### **HOOKS**

Hooks shall be solid, forged, heat treated alloy steel of rugged construction of the single hook type provided with a Standard depress type safety latch. They shall have swivels operate on ball or roller thrust bearings with hardened races. Lock to prevent hooks from swiveling shall be furnished.

#### **BRAKES**

Hoisting motors shall be equipped with electrically released, spring set, friction, shoe type brakes having torque capable of holding 125% of the full rated hook load. Brakes shall apply when either the motor controller or the main power switch is in "OFF" position, or in the event of power failure. Breaker should be equally effective in both the direction of rotation.

#### **ELECTRICAL REQUIREMENTS**

- Drive motor shall be as per IS: 325 companion specification enclosed. Motor shall be designed for frequent reversal, braking acceleration. Pullout torque shall be 2.15 times the rated torque. Pendant control switch, controller's resistors, controls, electrical protective devices, cables conductors, earthing guards etc. shall be as per IS: 3938. Limit switches shall be provided for over-hoisting over-lowering of two extreme ends of trolley travel.
- Control gear such as switch fuse, contactors, and relays shall be mounted in separate wall mounted panel in pump house.

#### **PENDANT CONTROL**

Pendant controls shall be provided with the pendant, which can be operated from a convenient position on the operating floor. The control push buttons shall be of spring returning type shall be of reputed make subject to owner's approval. The pendant switch box shall be capable of withstand rough haling. The mass of the pendant shall be supported independently of the electric cable by means of chain or wire rope the pendant shall be effectively earthed.

#### **TESTING INSPECTION AT MANUFACTURER'S WORKS**

- The manufacturer shall conduct in presence of Engineer-In-Charge all tests required to ensure that the equipment furnished shall conform to the requirements of the specification in compliance with the requirements of the applicable codes.
- Hook shall be tested in line with IS: 1875. Besides chemical mechanical tests, proof load test (at 125 % rated load) deflection test shall be conducted. Suitable NDE (e.g. UT DPT) shall be carried out before after loads test.
- Welds shall be subjected to suitable NDE e.g. RT/UT or DPE/MPE.
- Prior to dispatch, the crane shall be assembled subjected to check for deflecting span, load, alignment, no load full load and overload tests.

#### **TESTS AT SITE**

- After assembly erection at site, the crane shall be subjected to commissioning tests as laid down in the Indian Standard IS: 3177 IS: 3832 including deflection overload test.
- The contractor’s authorized representative at site shall submit he reports on the tests to client. The contractor shall furnish all test gadgets instrument necessary for conducting tests at site.

**PERFORMANCEGUARANTEE**

The equipment shall guarantee to meet the performance requirements by the specification rectification shall be carried out until satisfactory results are obtained before clearance for dispatch to site.

**ACCEPTANCE**

After erection crane, the owner will test all crane operation controls to determine that crane performance is satisfactory. Acceptance can take only if crane perform to the entire satisfaction of Engineer-In-Charge. The supplier shall depute to site his engineer to supervise the installation instruct the owner in operation maintenance.

**TECHNICAL DATA TO BE SUBMITTED WITHPROPOSAL**

Following technical information shall be furnished with the proposal.

- General arrangement drawings of the HOT crane with EOH showing overall dimensions clearance required.
- A write up on the crane controls along with the drawing indicating power control schemes.
- Calculations supporting motor horsepower selection for hoisting cross travel long travel motions.
- Calculation for selecting rope size, no. of falls F.O.S. (Factor of Safety)
- Calculation for selection of brake along with manufacturers brake selection charts/catalogues.
- List of vendors for bought out items.
- Details of manufacturing test facilities as available with the manufacturer.
- Experience list about the supply of similar cranes.

**TECHNICALPARTICULARS**

1	Location	Pump house
2	Crane rail support	R.C.C.brackets
<b>ELECTRICALLY OPERATED TRAVELLING (EOT) CRANE</b>		
3	Quantity	As per BOQ
4	Span	As per Pump house size
5	Run way length	As per Pump house size
6	Operating floor	Pump house floor level
7	Test load	125% of rated load of pumps, motor accessories.
<b>TRAVELLINGTROLLEY</b>		
8	Trolley type	Spur gear type
9	Wheels	Rim toughened,heat
10	Shaft	High, strength low, alloy Steel
11	Gears	From steel blanks
12	Frame	Rolled steel

13	Load chain	Alloy steel
<b>ELECTRICALLY OPERATED HOIST</b>		
14	Type of hoist	Spur geared, electrically, Operated
15	Capacity	As per Data Sheet
16	Lift	As per Data Sheet
17	Hoist drive	Electric motor
18	Gearing	Totally enclosed
19	Break	Electrically released spring set or friction disc type
20	Drum	Steel plates
21	Sheaves	Rolled steel
22	Bearing	Anti-friction roller bearing
23	Wire rope	6 Strs - 7 wires
24	Motor	Variable speed motor.
25	Control	Pendant
26	Creep speed control	As per requirement
27	Hook Approach	0.5 Mtr.
28	Lifting speed	As per requirement
29	Ladder	Required for servicing Crane and hoist

**DOCUMENT: DATA SHEET OF ELECTRICALLY OPERATED TRAVELING CRAN / HOIST**

SR. NO.	PARTICULAR	DESCRIPTION	BLANK DATA TO BE FILLED BY BIDDER
<b>1.0</b>	<b>REQUIREMENT DATA</b>		
1.1	Item	E.O.T. Crane with Electrical Hoist	
1.2	Location	Indoor in Pump House	
1.3	Quantity	as per price bid	
1.4	Capacity in TON	as per price bid	
1.5	IS Standard	IS - 807 & 3177	
<b>2.0</b>	<b>CRANE DATA</b>		
2.1	Make	Pl. furnish detail	
2.2	Model	Pl. Furnish detail	
2.3	Type	Single / Double Girder	
2.4	Class of Hoist	Medium Duty CI – II as per IS 3177 with latest amendments	
2.5	Lift in m.*	9.0 (or as per site requirement)	
2.6	Span in m*	7.5 (or as per site requirement)	

2.7	Bay length in m.*	30.0 (or as per site requirement)	
2.8	No. of Falls	2/4	
2.9	Travel speed in mtr./min. Longitudinal Cross	15 10	
2.10	Main Hoist speed- m/min.	2 to 2.5	
2.11	Creep speed in m./min.	0.5	
2.12	Fixed Girder Required	Pl. Furnish detail	
2.13	Type of Suspension	Hook	
2.14	Track	Min. 40 X 40 mm MS Sq. Bar	
2.15	Brakes	Electromagnetic type	
2.16	Method of Operation	Pendant Push Button	
<b>3.0</b>	<b>CONSTRUCTIONAL FEATURE</b>		
3.1	End Carriage	Pl. Furnish detail	
3.2	Bridge	Box Type/Standard I beam Type	
3.3	End Stopper	Steel End Stopper on either side of the bridge.	
3.3.1	Wheel Base	Pl. Furnish detail	
3.4	Gear	Made of EN 24 / EN 9 - precision machined, teeth cutting by hobbling machine & duly hardened.	
3.5	Wire Rope	Steel Wire rope 12 mm , 6 X 36 constru. Flex. Steel wire rope as per IS 2266 or as per design	
3.6	Hook	Forged steel single shank type – confirming to IS 15560 with thrust brgs., latch & anti-locking arrangement	
3.7	Rope Drum & Sheaves	MS Drum with grooving as per IS 3938	
3.8	Wheels	Made of Forged Steel confirming to IS 2707 GR- II duty/Steel cast	

		EN – 9, double flanged straight trade type	
3.9	Shaft	High Tensile Steel	
3.10	Trolley	MS Frame with wheels of Forged steel / EN – 9	
3.12	Bearings	All moving parts be supported on SKF/FAG anti fric.Ball/Roller bearings.	
3.13	Maintenance Platform/ access walkway	Maintenance basket type Platform for One man seat Required	
3.14	Painting	Required. Furnish detail.	
<b>4.0</b>	<b>ELECTRICAL DETAILS</b>		
4.1	Supply Condition	415 V +/- 10 % variation 50 Hz +/- 5 % variation +/- 10 % Combined variation	
4.2	Motor Standard	IS 325	
4.3	Control Voltage	110 V	
4.4	Class of Insulation /Drg. Of Protection	F / IP 55	
4.5	Temperature	Ambient- 50 Drg. C	
4.6	Make	As per Tender specs.	
4.7	Type of Motor	Hoist Duty	
4.8	Main Hoisting	Pl. Furnish detail	
4.9	L.T.	Pl. Furnish detail	
4.10	C.T.	Pl. Furnish detail	
4.11	Method of starting	Pl. Furnish detail	
4.12	Type of cooling	Pl. Furnish detail	
4.13	Total Connected Load-kw	Pl. Furnish detail	
<b>5.0</b>	<b>ACCESSORIES &amp; SERVICES REQUIRED</b>		
5.1	Mech. Stopper for LT C.T	YES	
5.2	Pendant with hanging chain/rope	YES	
5.3	Limit Switches for	YES	

	<ul style="list-style-type: none"> <li>• over hoisting</li> <li>• over lowering</li> <li>• over cross travel</li> <li>• over long travel</li> </ul>		
5.4	Trailing cable system	YES	
5.5	Control Panel	YES	
5.6	Isolation Switch for ele. Power	YES	
<b>6.0</b>	<b>WEIGHT</b>		
6.1	Weight of Hoist in kg	Please furnish	
6.2	Weight of Bridge in kg	Please furnish	
7.1	GA & Dimensional drg. of Crane assembly	PI furnish	
7.2	Data as required by IS 3177-77, Appendix-B, clause 2.2	PI furnish( In Separate Sheet)	
7.3	Complete Electrical circuit Diagram	PI furnish	
7.4	Catalogue of products	PI furnish	
7.5	QAP of products	PI furnish	
<b>8.0</b>	<b>TESTING</b>		
8.1	Visual inspection and Dimensional Check	Witnessing	
8.2	Performance test	Witnessing	
8.3	Overload test at 125% load	Witnessing	
8.4	Deflection Test	Witnessing	
8.4	Material Test certificates	Required	

- Note:
01. Manufacturer / supplier shall submit separate data sheet for each duty.
  02. For components (marked-M) material certificates shall be furnished
  - 03.( \* ) Contractor shall visit the site and obtain the data about span, lift, bay length, etc suitable for existing pump house and shall furnish in data sheet

**Item No. 140**

**Single phase borewell submersible pump motor set MOC: Casing: CI-FG260, Impeller: Bronze & Shaft: SS:410**

**Discharge -20 LPS, Head 90 Mtr, HP- 1.5**

**SUBMERSIBLE PUMP SET: (Testing at Manufacturer's Works)**

Submersible pumping set suitable for Tubewell assembly fitted with dynamically balanced bronze impellers mounted on a stainless steel pump shaft with shaft protection sleeves having stage bowls of closed grained cast iron. The pump will be fitted with built in non-return valve and shall be suitable for direct coupling to the squirrel cage electric induction, water cooled type submersible motor suitable to operate on  $415 \pm 10\%$  V, 3 phase, 50 cycles/sec. A.C. Power Supply and 2900 rpm (nominal) speed and capable to give a discharge against a particular head as is mentioned in Schedule E (HP of Motor must be as per CPHEEO manual). Other specifications shall be as per following:

The Margin of safety for motor as per CPHEEO Manual

1	UP TO 1.4 KW	50%	UP TO 2 HP
2	1.5-3.7 KW	40%	2 HP-5 HP
3	3.7-7.5 KW	30%	5 HP-10 HP
4	7.5-15 KW	20%	10 HP – 20 HP
5	15-75 KW	15%	20 HP – 100 HP
6	ABOVE 75 KW	10%	100 HP and above

**PUMP SET:**

1. A Standard hydrostatic test on all pressure containing parts shall be made at 1.5 times the maximum discharge pressure.
2. The bowls shall be equipped with replaceable casing bearing.
3. The bowl assembly shall bear a name plate preferably embossed information as per following:
  - a) Name of the manufacturer or trade mark.
  - b) Serial number of the pump set.
  - c) Pump type.
  - d) Number of stages.
  - e) Total head.
  - f) Capacity.
4. The impeller shall be of enclosed type equipped with seal rings on their hubs. Seal rings shall be provided either with impeller or in the bowl.
5. The pump shaft shall be guided by bearing provided in each bowl of above and below the impeller shaft assembly. The shaft without sleeves shall have a surface finish 0.75 micron Ra Max.
6. The opening in the suction case for the entrance of water shall be of proper size and shape to avoid eddy currents.
7. The suction case shall be fitted with a strainer made of corrosion resistant material.
8. Suitable sand guard shall be provided just above the suction case bearing to prevent the entry of foreign matter into the suction case.
9. Non return valve shall be provided above the pump discharge case.

**SUBMERSIBLE MOTOR:**

1. The submersible motor shall be squirrel cage induction motor.
2. The winding of motor shall be wet type.
3. The motor shall be suitable for operation voltages and frequency conforming to IS 585-1962 (revised) "Voltages and frequency for A.C. transmission and distribution system"
4. The earthing of the motor shall comply with IS: 3043-1966 code of practice for earthing.



5. The Thrust bearing shall be of adequate size to withstand the weight of all rotating parts as well as the imposed hydraulic thrust. These shall be lubricated suitably.
6. The Motor winding and nearing bushes of the rotor shaft shall be cooled/lubricated by pure water filled in the motor before erecting the pump set.
7. The motor shall be protected by means of cable glands, rubber seals etc. from ingress of tube well water, sand and other foreign matter.
8. The thrust bearing housing shall be provided with a drain plug to empty the pure water filled into the thrust bearing housing/Motor.
9. The rotor shaft shall be provided with shaft protecting sleeves having a surface finish of 0.75 micron Ra max.
10. The Motor shall be provided with a breathing attachment like bellows, diaphragm etc. to compensate the Volumetric variations due to change in temperature.
11. The motor shall be made of corrosion resistant materials or suitably treated materials to resist corrosion.
12. The motor shall have a name plate preferably embossed on body of motor giving the following information :
  - a) Submersible Motor;
  - b) Name of Manufacturer;
  - c) Manufacturer's number and frame reference;
  - d) Type of duty;
  - e) Frequency in Hz;
  - f) Number of Phases;
  - g) Rated output in HP/KW;
  - h) Rated voltage and winding connections;
  - i) Current in amperes at rated output.
  - j) Speed in RPM at rated output.

**DATA OF PUMP SET:**

Specifications shall be furnished in the following manner:

- 1) Make of motor
- 2) Model of motor
- 3) Model of Pump
- 4) Discharge in LPM
- 5) Total Head
- 6) Net effective head
- 7) No. of Stage
- 8) Pump outlet size in mm.
- 9) O.D. of pump in mm.
- 10) Speed of pump set
- 11) Method of starting
- 12) Size of Cable
- 13) Motor HP
- 14) Length of cable with motor

The performance details as per enclosed schedule 'E' are to be submitted separately.

**Item No. 141**

**Monoset sub. pump 3 phase 400/440 volt, 50 c/s. A.C. Supply & 2900 RPM , as per IS 14220**  
**MOC : Casing: CI-FG260, Impeller : Bronze & Shaft : SS:41**  
**Discharge -220 LPM, Head 22.5 Mtr, HP- 4**

**Submerged Centrifugal Pump Set:**

1. The pump set shall be of compact unitary mono block type construction. The pump casing shall be of high efficiency, bowl diffuser or volute casing type with the impeller mounted directly onto the extended solid motor shaft (without any couplings). Numbers of stages shall preferably be one or two stages. The stages shall be decided as per maximum achievable efficiency as per HIS and / or as prescribed in data sheet.

2. The pump set should be single / two stage type i. e. it should have only one / two impeller (s) & one / two casing – two stages shall not be allowed (except for head  $\geq$  90 m). Pump casing shall be high efficiency, centrifugal volute type.

3. The pumps are to be installed directly into the water body (canal / sump / river or unscreened jack well), so it may suck up lot of silt, clay, pebbles & vegetation. Therefore it should be reliable & robust.

**4. Installation**

**4.1** The pumps should always be suitable for vertical or horizontal; permanent or portable installation & be interchangeable between these modes throughout their working life time (by suitable use of base frames / auto coupling systems which can be ordered either during the main purchase order or at a later stage).

**4.2** The detailed scope of supply & mode of installation shall be as per the specific tender data sheets or as per CDR instructions.

**4.3 Possible Installation Arrangements****4.3.1 Horizontal, Portable, Wet (Submerged) Installation:**

4.3.1.1 The pump shall be offered with fully portable & robust MS portable base frame.

4.3.1.2 In case the pump is to be installed on a concrete canal bed where vibrations are to be suppressed; the pump should be provided with anti vibration shock pads between the pump & the base frame.

**4.3.2 Vertical, Portable, Wet (Submerged) Bottom Rested Installation:**

4.3.2.1 The pump shall be offered with a fully portable & robust M S portable base frame which allows for installation of the pump in either vertical or horizontal mode – i. e. both modes should be possible with the same base frame which is rested on the bottom of the water body.

**4.3.3 Vertical, Portable, Wet (Submerged) Suspended Installation:**

4.3.3.1 The pump shall be offered with a fully portable & robust MS portable base frame which allows for installation of the pump in vertical suspended installation within deep water body. In such a case, the motor shall be at bottom & the pump portion shall be at the top. The delivery column pipe shall be flange bolted on to the pumpset flange.

4.3.4 Vertical, Permanent, Wet (Submerged) Installation (Auto Coupling System):

4.3.4.1 The pump set should be coupled to the rising main by an automatic coupling system. The automatic coupling system should have a pedestal (which is bolted on to sump bottom by pre grouted foundation bolts) which is permanently bolted onto the rising main.

4.3.4.2 The automatic coupling system design should be such that a unibuilt bend is integrally cast with the pedestal. This design obviates the need of bolting on a separate duck foot bend to pedestal. Separately bolted CI IS DF bends are not allowed as they are not conducive to replace flange gaskets (between the CI IS DF bend and the pedestal).

4.3.4.3 To prevent swiveling of the pump set (while lowering into & pulling out of sump), larger (with discharge size  $\geq 125\text{m}$ ) & / or deep installed (with installation depth more than 10 m) pumps, the auto coupling system should preferably have two guide elements (either pipes or wires). Single guide element is not acceptable.

4.3.4.4 To "fish out" a vertically installed submerged pump set (even if a chain has not been attached to the lifting hook prior to the pumpset being lowered) the pump should have a self centering lifting hook. Its design should be such that the lifting chain's hook can be engaged to the pump's lifting hook without the need for man to enter the wet sump to engage the same.

4.3.4.5 The scope of supply shall include auto coupling system (with integral duck foot bend), SS foundation bolts, alloy steel chain & guide rail pipe / wire (as per depth of sump / jack well).

Pump End Design

4.4 Speed

4.4.1 To achieve best efficiency life, the speed of the pump set should be such that the specific speed ( $N_s$ ) of the pump (calculated as per for single stage, single suction impeller pumps assuming duty point as the best efficiency point) is to be calculated as follows:

Where  $N_s = 3.65 N \times \sqrt{(Q \text{ m}^3/\text{s})}$

$(H \text{ m})^{0.75}$

Ns = Specific speed

N = The operating speed of the pump in rpm

Q = The rate of flow in cubic meters per second

H = The rated head per stage of the pump in meters

4.4.2 The specific speed shall preferably be in the range of 140 to 200. It should be nearer to 170 as far as possible to achieve best efficiency. However calculation of specific speed for duty parameters given in data sheet (price bid) shall be given by the manufacturers' of the pump.

4.4.3 Further motors rated above 100 HP & / or with pump's duty point flow rate equivalent or in excess of 360 m3/hr shall be limited to not more than 1450 rpm.

4.5 The pump shall be capable of developing the required total head at rated capacity for its continuous operation. Pumps of particular category shall be identical and shall be suitable for parallel operation.

4.6 The head capacity curve shall be continuously rising towards shut off with the highest at shut off. The shut off head shall be at least 120 % of the specified duty point head.

4.7 The impeller shall be of high efficiency multi channel enclosed type (except for specific speed  $\geq 90$  where semi open impellers shall be allowable).

4.8 Suction Strainer

The pump is fitted directly with a suction bell mouth to which is compulsorily fitted a heavy duty strainer (to avoid pick up of gravel, pebbles, vegetation, etc.) Sizing of the suction strainer should be larger of the following two: At the duty point flow, the suction velocity (at strainer holes), should never exceed 3.0 m/s & At the duty point flow, the total cumulative suction area of all the strainer holes should always be  $\geq 2.0$  times the impeller's suction eye area. However large & slow speed pumps (with solid handling ability  $\geq 75$  mm & of speed  $\leq 1000$  rpm) may be offered without suction strainer. The pump's solid handling size & maximum hole size of suction strainer should be as per below mentioned chart.

Table 1: Design of strainer		
Pump delivery size	Minimum thickness of suction strainer	Maximum permissible hole size of suction strainer
DN 25, DN 32 & DN 40	2 mm	Not more than 4 mm
DN 50 & DN 65		Not more than 6 mm
DN 80		Not more than 8 mm
DN 100		Not more than 10 mm

DN 125	3 mm	Not more than 12 mm
DN 150		Not more than 14 mm
DN 200	5 mm	Not more than 21 mm
DN 250		Not more than 30 mm
DN 300 & DN 350		Not more than 40 mm
DN 400 & above	7 mm	Not more than 50 mm

4.9 The pump set shall be suitable for starting with delivery valve open as well as closed at any operating point. The motor should also start accordingly. The pump set shall be capable of withstanding the accidental rotation in reverse direction. Complete performance curve, data sheets, G A drawings showing installation shall be submitted along with the technical bid.

4.10 Pumps having less than minimum guaranteed efficiency as mentioned in the data sheet of pump derived per HIS 2010 are not acceptable.

## 5 Submerged Induction Motor End Design

5.1 The motor shall be of squirrel cage, induction type, air filled yet capable of water immersion upto 20 mwc for S1 duty. Motors with oil or water filled windings shall not be allowed.

5.2 It is rated for  $415 \pm 10\%$  V, 3 phase  $50 \pm 5\%$  c/s AC.

5.3 Its winding should be of class "H" insulation (withstanding winding hot spot temperature of up to  $185^{\circ}$  C respectively) while the nominal temperature rise of winding hotspot should not exceed that of class "B".

5.4 It should be wound using dual coated, super enamelled; Copper wire with high temperature index as per IS: 4800 Part 13. PVC / Polypropylene – polyethylene insulation for winding wires shall not be allowed.

5.5 Motor's insulation should be vacuum varnish impregnated & oven baked to ensure a moisture impervious & mechanically robust insulation. Dip or pour type air dry varnishing shall not be allowed.

5.6 The Power rating of the motor shall be the larger of the following:

- a) Reserve power margin as tabulated in table I of the power input to the pump at duty point at a speed corresponding to the frequency of 50 Hz.
- b) Maximum power input while operating solo or in parallel within maximum and minimum system resistances corresponding to the speed at 50 Hz.
- c) Rating of motor shall be suitable to cover load for entire operating range (preferred / recommended area of operation i. e. – 30 % to + 20 % of design flow rate) of pump model offered with minimum rating of kW.
- d) Rating of motor shall be suitable to cover load for entire operating range of pump model offered with

minimum rating of kW in case of pumps in parallel operation. In this case operating zone shall mean from shut off to run out position. Minimum rating of motor and efficiency at full working load shall not be less than prescribed rating in data sheet.

Table I

MOTOR BHP	% OF PUMPING DESIGN POINT BHP
10 to 20 BHP	120 %
20 to 100 BHP	115 %
Above 100 BHP	<b>110</b> %

6.7 The motor's rotor shall be of rugged construction either dual cage copper bar brazed / die cast aluminium type to ensure long corrosion free service However motors rated above 300 HP rotors shall be dual cage copper bar brazed only to ensure ease of onsite repairing, beneficial fly wheel type inertial effect which reduces detrimental effects of water hammer & Better motor efficiency & cooler operating temperature.

#### 6.8 Motor Cooling

6.8.1 To restrict the dead water level (in case of vertical installation) in the sump to 1 meter, medium sized, vertical pumps ( $\geq 75$  HP) should have a cooling jacket i. e. motor cooling is accomplished by circulation of pumped water between the motor casing & the jacket shell. This jacket shell is fed by cold water from the pump casing & discharges its heated water back into the sump (in case of wet installation) or pump casing (in case of dry installation) by integrally cast ducts. There should not be any pipes, hoses etc. for this circulation.

6.8.2 In case the pumps are to be installed horizontally or the dead water level in the sump exceeds 1.5 meters from the pump centre line, the motor can be cooled just by water immersion i. e. no jacketing is required. The mode of cooling (either direct immersion or via jacket cooling) is clearly mentioned in the prescribed data sheet.

#### 6.9 Motor Protection

6.9.1 Thermal overload protectors (Bi metallic over load relays) should be embedded in each phase of the stator winding to detect over heating & trip the motor from the control panel in the event of the temperature exceeding the safe operating limit (above  $130^{\circ}$  C).

6.9.2 To detect primary mechanical seal's leakage a moisture sensor shall be provided in intermediately oil chamber (& not in the motor casing or elsewhere) – this shall detect water mixing in oil by mode of increased leakage current from the moisture sensor.

## 6.10 Cables

6.10.1 A watertight cable junction box sealed from the motor shall be provided for the motor power and signaling cables.

6.10.2 The cable shall be brought directly out of the submerged motor without joints, and shall be of sufficient length, minimum 10 m to be terminated in an IP 67 junction box outside adjacent to the wet well & above the HFL. They shall be sized in accordance with the electricity utility regulations and BS 7671.

6.10.3 It should have power as well as control cables of dual sheathed EPRS / PVC round type with Copper core of required size as per detailed engineering. However the cross section of the cable shall be enough to ensure a voltage drop of not more than 2 % at actual site conditions.

## 7 Shaft & Bearings

The solid shaft shall be supported by heavy duty Ball or Roller bearings with a minimum  $L_{10}$  life of 75,000 hours in accordance with BS 5512. The bearings of pumpsets rated up to 200kW should be permanently greased with premium quality, high temperature, long life grease thereby obviating the need of relubrication for up to  $L_{10}$  life of the bearings. The bearing should be of Metric Series & not Imperial ones. Larger pump sets should be equipped with water proof regreasing nipples.

7.1 The bearings should be permanently greased with premium quality, high temperature, long life grease. The bearing should be of Metric series & not Imperial ones Oil lubricated bearings shall not be allowed.

7.2 In case the motor is to be driven via a VFD, atleast one of the bearings (DE or NDE) should be current insulated to prevent "electric fluting damage" caused by Harmonics.

## 8 Stuffing Box / Oil Chamber

8.1 The pressurised entry of water into the motor (from the pump's volute casing) should be prevented by two separate mechanical seals in mounted in a tandem mode within an oil chamber.

8.2 The primary (inboard) seal should be of Silicon Carbide or Tungsten Carbide faces to withstand erosive wear due to any silt particles. The secondary (Outboard) seal should be of Carbon v/s Cast Chrome Molybdenum Steel or Silicon Carbide or Tungsten Carbide. Thermally unstable materials like Alumina / Aluminum Oxide are not allowed.

9 Energy Cost Loading

There shall not be any cost loading on grounds of efficiency. However pumps' with efficiency lower than the minimum acceptable efficiency shall not be accepted. The manufacturer shall provide pump & motor efficiency at duty point.

10 Testing

10.1 The pump sets shall be tested at the in accordance of ISO 9906 or IS 9137 or IS 5120 (Tolerance Class 2) with or without VFD. However full load / speed testing is preferable.

10.2 In case the pumps are to be installed on specialised auto coupling device, where no external bolting between the pump and the delivery piping is possible – so it is absolutely essential that this joint is leak free or else there may be a substantial pressure/ leakage loss between the pump and the auto coupling system (as they are not clamped together like conventional gasketed & bolted flanged joints). So it is compulsory that such pumps should be tested on an auto coupling system only i. e testing the pump with flange, gasket bolted delivery piping is not allowed.

10.3 The Flow shall be measured by full bore electromagnetic or ultrasonic flow meters (of 0.5 % or less accuracy class).

10.4 In case of MNC pump manufacturer not having adequate testing facility within reasonable distance (i.e. decided by the area of operation of the TPI), the pumps should be tested at the alternative facilities & internal test certificates shall be submitted for review to the TPI. The customer may demand field testing of such (unwitnessed) pumps within 30 days of installation which the contractor / manufacturer is bound to offer at no extra cost.

10.5 Pump testing should be carried out preferably with VFD, in case the pump sets are to be used with VFD then the testing has to be conducted compulsorily with VFD (to ascertain compatibility with VFD).

10.6 In case of MNC pump manufacturer(s) not having adequate testing facility within reasonable distance (i. e. decided by the area of operation of the TPI), the pumps should be tested at the alternative test bed or at field within 30 days of installation which the contractor / manufacturer is bound to offer at no extra cost. The field testing shall include the following:

10.6.1 Motor Routine Tests:

10.6.2 IR

10.6.3 HV



- 10.6.4 No Load Amperes, Vibration etc.
  - 10.6.5 Pump performance testing (in accordance with IS 5120 / ISO 9906, Grade 2 – 5 % / ISO 2548 – 5%)
  - 10.6.6 Measurement of head, discharge, motor input at least 6 different points to plot the actual Performance curves
- 11 The entire arrangement for such field test shall have to be made by the contractor & all the extra charges for such field testing shall exclusively be borne by the contractor. It is clarified that, in case of field testing failure, GWSSB reserves the right to detain the pumps in their custody until the contractor replaces the failed pumps with new pumps which shall again be subjected to retesting. No extra charges shall be paid by GWSSB to the contractor.
- 12 Materials of construction

Motor casing, oil chamber & other parts	Cast Iron (FG 260 as per IS 210 or GG25 or EN JL1040)	
Motor 's (squirrel cage) rotor	Motors ≤ 300 HP	Aluminium Die Cast or Dual Cage Copper Bar
	Motors > 300 HP	Dual Cage Copper Bar
Motor cooling jacket (if applicable)	SS 202 or Epoxy Coated MS	
Mechanical seals	Double mechanical seal should be fitted. <u>Primary (Inboard)</u> : Silicon Carbide v/s Silicon Carbide or Tungsten Carbide v/s Tungsten Carbide <u>Secondary ( Outboard)</u> : Carbon v/s Cast Chrome Molybdenum Steel or Silicon Carbide or Tungsten Carbide	
	Elastomers: <ul style="list-style-type: none"> <li>All "O" rings of Viton only</li> <li>Bellows of either Viton or Nitrile</li> </ul>	
Fasteners	Stainless Steel or Hot Dip Galvanized BHT Alloy Steel	
Auto coupling system (if applicable)	Pedestal cum Delivery Bend	Cast Iron (FG 260 as per IS 210 or GG25 or EN - JL1040)
	Slider Bracket	Ductile Cast Iron or Cast Steel (SG 400/12 or EN - JS1050 or GGG 40) or WCB
	Guide Rail Pipes / Wires & Foundation Bolts	SS 304 or Higher grade
Pump (volute / bowl) casing	Pumps with Duty Point Head rating ≤ 80 m & Delivery Size ≤ DN 100 mm; Pumps with Duty Point Head rating ≤ 60 m & Delivery Size ≤ DN 125mm	Cast Iron (FG 260 as per IS 210 or GG25 or EN -JL1040)
	Pumps with Duty Point Head rating > 60 m & Delivery Size > DN 125 mm Pumps with Duty Point Head rating > 80 m	Ductile Cast Iron or Cast Steel (SG 400/12 or EN - JS1050 or GGG 40 or ASTM 80 -55 - 06 or WCB)

Suction bell mouth & miscellaneous pump parts	Cast Iron (FG 260 as per IS 210 or GG25 or EN - JL1040)
Impeller	Cast Austenitic Stainless Steel (SS 316 or CF 8M or 1.4406)
Wearing rings (suction head casing & impeller)	Cast Austenitic Stainless Steel (SS 316 or CF 8M or 1.4406) or Bronze
Pump motor shaft	Stainless Steel (SS 410 or SS 430 or 1.4021 or 1.4460)* * Larger Motors (i.e. > 265 HP) may be supplied with High Carbon Alloy Steel Shaft (EN 8 or DIN 1.7225 or others) protected with SS 316 Shaft Sleeves
Suction strainer	MS (C15) Fabricated with Epoxy Coating
Portable stand (if applicable)	MS (C15) Fabricated with Epoxy Coating

**13 Data Sheet for submerged centrifugal pump sets**

1	Application	Submerged centrifugal pump is used for water intake / transfer / lift & mounted in canal, sump, lake or jack well either vertically or horizontally depending upon the site conditions (To be clearly specified)
2	Type of motor	Squirrel cage induction type with IP 68 enclosure
3	Rated flow	___ m <sup>3</sup> / hr at 50 Hz
4	Rated head	___ mwc at 50 Hz
5	Number of pump sets	As per price bid
6	Supply system fault level	20 MVA
7	Supply neutral	Solidly earthed
8	Rated voltage / rated HP	415 V / Suitable for pump as per previously outlined margin norms
9	Number of phases & frequency	3 Phase & 50 Hz
10	Supply conditions	± 10% voltage variation ± 5% frequency variation ± 10% combined voltage and frequency variation
11	Speed	960/1450/2900 rpm (To be specified in data sheet by the department)
12	Duty condition as per IS 325 or equivalent	S1 suitable for constant operation
13	Method of starting	DOL up to 7.5 HP Star Delta up to 20 HP ATS for up to 75 HP Soft Starter or VFD for above 100 HP & larger pump set
14	Starting torque & pull out torque	Sufficient enough to start the pump with delivery valve open and when other pumps are running. Sufficient to bring the motor to normal speed in minimum time
15	Class of insulation & temperature rise by thermometer	Minimum class "F" but temperature rise restricted to that of class "B" i. e. 75 <sup>0</sup> C
16	Ambient temperature	45 <sup>0</sup> C
17	a) Type of cooling b) Degree of protection	Surface cooled by circulation of water through jacket shell ≥ IP 68 (should withstand up to 20 m of water immersion) on S1 basis
18	Cable details	Four cores (minimum 1/4 cores required as Earth)
19	Shaft orientation horizontal / vertical	Pump set should be suitable for any position i. e. vertical / horizontal / inclined
20	Type of bearings	Ball / Roller / Thrust Anti Friction type (life time lubricated)
21	Bi metallic thermal over load relay for winding required?	Yes, one in each phase; for trip, alarming and indicating set to trip @ 130 <sup>0</sup> C
22	Bearing over temperature detectors	Required for motors > 150 HP by bi metallic overload thermal switches set to trip @ 95 <sup>0</sup> C

23	Winding connections	6 Terminals	
24	Standards to be followed	IS 325, 8225, 4889, 4772, 4029, 4691 and other relevant Indian Standard or equivalent BSS & Testing as per ISO 9906 / IS 9137 / IS 5120	
25	Scope of Supply	v	SITC of Pump set with ___ m cable along with ___ m alloy steel chain & install as per any of the 3 mentioned modes (shall be informed depending on site conditions)
		Any one of three to be given by the department	Pump set along with auto coupling system for permanent vertical wet installation along with ___ m guide pipe / wires (1/2 Nos ) & S S foundation bolts
			Pump set fitted with base frame vertical & / or horizontal, portable, wet (submerged) installation
			Pump set suitable for vertical installation flange suspended on delivery column pipe

**Item No. 142**

**DOL / Star Delta starter suitable for local & remote pump control application consisting of MPCB, overload relay and contactors as per Type II coordination including digital voltmeter, analogue ammeter with selector switch, run hour meter, required protective relays & control accessories.**  
**b)D. O. L. up to 5 HP**

The MCC shall have degree of protection of the enclosure IP-54. The M.C.C. shall be of draw out and extensible type. The lighting boards shall not be draw-out type. Main PMCC Panel for STP shall be double busbar type. One busbar is utilised for Torrent power supply & another busbar is utilised for Bio Gas generator power supply. Necessary interlocking arrangement shall be provided between both power system.

The MCC shall be free standing, extensible, metal enclosed fixed compartment - alised, modular type, dust and vermin proof suitable for indoor installation. The switchgear shall be assembled out of vertical panels of uniform height not exceeding 2450 mm. The maximum height of the operating handle/switches shall not exceed 1800 mm and the minimum not below 300 mm.

The switchgear shall be designed to ensure max. safety during operation, inspection, connection of cables relocation of outgoing circuits and maintenance with the energised bus system and without taking any special precautions. The switchgear shall permit max. Interchangeability and shall be extensible on either side

The switchboard / MCC shall be sheet steel clad with the frame fabricated out of 14 SWG cold rolled sheet steel and doors/ covers also of 14 SWG cold rolled sheet steel having integral base frame for each vertical panel. All hardware shall be corrosion resistant. All joints and connections of the panel members shall be made of galvanised and passivated or cadmium plated high quality steel bolts, nuts and washers secured against loosening.

The switchgear shall be suitable for bottom cable entry. Each MCC panel shall have a separate cable alley of 150 mm minimum width. Motor starter and switch fuse units shall be in Multitier arrangement in single fixed execution. All auxiliary devices for control, indication, measurement and protection such as push buttons, control and selector switches, LED type indicating lamps, Digital metering instruments shall be mounted on the front side of the respective compartment. Components requiring frequent inspection

during operation shall be provided with an anti-corrosive heater rated for 240 AC +/-10% supply with a switch, fuse and a thermostat.

MCC must incorporate all the feeders required for above mention capacity including spare feeders as mentioned elsewhere in this tender. All the bus bars including main bursars must be designed as per the rating of concerned/associated switchgear.

Main bus bars shall be of high conductivity having uniform current rating throughout the length. Horizontal and vertical busbars shall be sized depending upon the max. expected current and to limit the max. operating temperature at specified design ambient temperature to 85 deg. C for normal operating condition and the 200 deg. C for short circuit condition considering installation in poorly ventilated area.

Adequately sized (taking current density 1.5 Amp/Sq.mm.) Electrolytic Tinned Copper (Cu.) busbars with heat shrinkable coloured sleeve running horizontal in a separate enclosure shall be provided for space heaters, control supply and meter requirements. Necessary tee-off connections shall be used for distributing auxiliary supply to each vertical panel. All busbars shall be colour coded and designed to withstand specified short circuit current for one second. Copper used must be electrolytic tinned copper only.

Copper earth bus shall be adequately sized and provided throughout the length of the switchboard with provision for interconnection to earthing grid. All non-current carrying metal parts of the mounted equipment shall be earthed. Doors and moveable parts shall be earthed using flexible copper connections. All feeders must be separated using metal partitions

Inside the switchboard, the wiring for power control, protection and instruments circuits shall be done with PVC insulated copper conductors having 660/1100 V grade insulation. Min. size of control wire shall be 1.5 mm<sup>2</sup> copper for circuits having MCB'S rating of 10 Amps. or less. For higher MCB'S rating control circuits, min. 2.5 mm<sup>2</sup> copper conductor shall be used.

Elemex type terminals shall be acceptable for wires upto 10 mm<sup>2</sup> size and for conductors larger than 10 mm<sup>2</sup> bolted type terminal with crimping lugs shall be provided. Each wire shall be terminated at a separate terminal.

All motor starter shall be D.O.L. type and upto 7.5 H. P. and star-delta type above 7.5 H.P. unless otherwise specified. All the cast resin C.T.'s and energy meter must be of accuracy class 0.5.

All switches/MCCB shall be load break, heavy duty, air lock type with 2NO + 2NC the operating handle mounted on the compartment door complete with necessary interlock and defeat mechanism. All fuses shall be non-deteriorating HRC cartridge pressure filter, link type the connector shall be air lock type having AC-3 duty rating.

Micro processor Based Motor protection relays with over load, short circuit, singal phasing, earth fault, Reverse rotation protection shall be used for motor rating above 7.5 H.P..

All Digital indicating instrument shall be moving iron flush mounting type of 96 x 96 mm sq. pattern. However 72 x 72 mm instruments may be acceptable for outgoing feeders in the MCC. All control/selector switches shall be rotary back connected type having a cam operated contact mechanism with pistol grip handle for circuit breaker control and knob type handle for other applications. All motor starter feeders shall have stop push buttons and trip indication lamps. Incomer to MCC shall have a 415 V MCCB / TPN with primary fuse, secondary MCB along with a voltmeter and a selector switch. The incomer to MCC shall have Digital KWH meter with protection MCB's etc. to record energy consumed in the plant including lighting for the plant. A separate Digital KWH meter may be used the lighting consumption. Accuracy class of Digital KWH meter and CT's must be 1.0. All CTS used in panel must be resin cast type.

All metal parts shall be thoroughly cleaned degreased and made free from rust. After application of the primer, the switchboard shall be spray painted with two coats of final paint colour shade.

Micro processor Based Motor protection relays with over load, short circuit, single phasing, earth fault, Reverse rotation protection shall be used with all motor starters above 7.5 HP motors.

A centrally located engraved nameplate shall be provided for the switchboard. Each module shall have engraved nameplate bearing data as per approved drawings. Nameplate or polyester adhesive stickers shall be provided for each equipment mounted on the switchboard. One feeder of each rating must be provided in the switchboard as a spare feeder. The contractor shall have to submit the G.A. Drawing /and/or single line diagram of MCC showing the feeder arrangements along with the technical bid.

**General Requirements of The Panel:**

- The tenderer must have CPRI approval for manufacturing panel for the tenderer, who has not CPRI approval has to make panel from CPRI approved panel manufacturer only and that case contactor has to submit the details of Panel Manufacturer.
- 125 amp and above capacity MCCB must be complete with the operating handle interlock,
- All the L.T. switch gear unit should be confirm to IS-13947.
- All the CT's shall have cast resin type only and each CT should have short link.
- Indication lamp shall be LED type panel mounted, low power consumption, Min.100000 hrs. of Life, O/L and S/C protected with its holders etc. Suitable for specified voltage shall be used.
- All the measuring instruments should be of Accuracy Class 1.0.
- Each door of the panel should be earthed separately by Flexible link.
- The above cubicle pattern L.T. switch board comprising of Incoming and Outgoing described above must be complete with necessary floor stands, foundations bolts, copper inter connections between bus bars and incoming / outgoing, inter wiring with PVC copper cables, labels marked for incoming /outgoing / earthing terminal etc. and other required major / minor items.
- All internal wiring work should be permanently marked / labelled at terminations with numbers or letters corresponding to diagram.
- A copper earth bus of appropriate size must also run throughout the panel.
- All the MCCBs should be with front operated mechanism with 2 NO + 2NC Auxiliary contact.
- Ample space in each compartment shall be provided for easy maintenance and repairing.
- Control supply of each individual starter feeder shall be protected with the suitable capacity of the MCB.
- Auto Manual switch should be provided for each pump set outgoing feeder.
- Operating handle of switch gear, control unit for panel shall not be above 1.8 Mtr. From operating platform.

**Item No. 143**

**PVC insulated flat submersible cable as per detailed technical specifications of R/C of GWSSB conforming to IS 694, IEC 60227 / 60228.**

**b) 1 R x 3 C x 2.5 mm<sup>2</sup>**

- Loading, unloading and delivery of cable at site to store
- Internal shifting of cable
- Supply and fixing of cable clamp, bracket, support, cable tray/rack, encasing in GI Pipe, route markers.
- Earthing the glands and armouring with earthing and jumper and also connecting to common earth bar.
- Testing & submission of all cables laid at head works

The diameter/height/size/type will be as shown in BOQ.

**Design Conditions:**

All equipment and materials will be selected and rated for use at the following site conditions.

- Summer outdoor temperature: 55°C.
- Ground temperature: 40°C.

- Earth Resistivity: 200 deg.C.cm/w
- Relative Humidity: 95% Max.
- Atmospheric Condition: Non Corrosive, Humid and dusty

**Specification:**

This Specification is drawn out for supply, installation, connection, testing and commissioning of point wiring for light points, ceiling fan points, exhaust fan points, bell points, 5A / 15 A socket outlet points, power socket outlet points, etc. This specification also includes fixing of light fixtures, ceiling fan, wall fan, exhaust fan, bell etc.

**Standards:**

The following Indian Standards, other relevant applicable Indian and International standards and Indian Electricity Rules and Regulations, Indian Electricity Act, relevant specifications, drawings and instructions issued by architect / Consultant office regarding the work, shall be followed by the tenderer.

IS	732	Code of practice for Electrical Wiring Installation (System Voltage not exceeding 650 V)
IS	1646	Code of practice for Fire Safety of Buildings (General) Electrical Installation.
IS	4648	Guide for Electrical Layout in Residential Building
IS	694	PVC Insulated Cables
IS	8130	Specifications of Conduits for Electrical Installation
IS	2509	Rigid Non-Metallic Conduits for Electrical Wiring
IS	6946	Flexible (Pliable) Non-Metallic Conduits for Electrical Installation.
IS	9537	Specification of PVC Conduits
IS	3415	Fittings for Rigid Non-Metallic Conduits
IS	1653	Rigid Steel Conduits for Electrical Wiring
IS	2667	Fittings for Rigid Steel Conduits for Electrical Wiring
IS	3419	Specification for Fittings of Rigid Non Metallic Conduits
IS	3480	Flexible Steel Conduits for Electrical Wiring
IS	3837	Accessories for Rigid Steel Conduit for Electrical Wiring
IS	1293	3 Pin Plugs and Sockets
IS	3854	Switches for Domestic Purpose

The relevant requirement of following act, rules and regulation shall also be fulfilled by the tenderer.

- Indian Electricity Act 2003 (as amended up to date)
- Indian Electricity Rules 1956 (as amended up to date)

- Regulations laid down by the Chief Electrical Inspector of the State
- Regulations laid down by the power supply provide department
- Regulations of FIA of India
- Regulations laid down by the Factory Inspector of the State
- Any other regulations laid down by the local authorities

Installation of any equipment shall be done according to the guide line provided in the Installation & operation manuals of equipment manufacturers. All the Work shall be done with latest best practices in the industry.

**Construction:**

**General:**

The medium voltage cables shall be supplied, laid, connected, tested and commissioned in accordance with the drawings, specification, relevant Indian Standards specifications, manufacturer's instructions. The cables shall be delivered at site in original drums with manufacturer's name, size, and type, clearly written on the drums.

**Material:**

Medium voltage cable shall be XLPE insulated. PVC sheathed, aluminium or copper conductor, armoured conforming to IS : 7098 Part I.

**Type:**

The cables shall be circular, multi core, annealed copper or aluminium conductor, XLPE insulated and PVC sheathed, armoured or un armoured.

**Conductor:**

Uncoated, annealed copper / aluminium, of high conductivity up to 4 mm. Size, the conductor shall be solid and above 4 mm., conductors shall be concentrically stranded as per IEC : 228.

**Insulation:**

XLPE rated 70 c. extruded insulation.

**Core Identification:**

- Two Core: Red & Black
- Three Core: Red, Yellow & Blue
- Four Core: Red, Yellow, Blue & Black
- Single Core: Green, Yellow for earthing
- Black shall always be used for neutral.

**Assembly:**

Two, three or four insulated conductor shall be laid up, filled with non-hygroscopic material and covered with an additional layer of thermoplastic material.

**Armour:**

Galvanized Steel flat strip/round wires applied helically in single layers complete with covering the assembly of cores.

For cable size upto 25 sq. mm: Armour of 1.4 mm dia G. I. round wire

For cable size above 25 sq. mm: Armour of 4 mm wide .8 mm thick G. I. strip

**Sheath :**

XLPE 70 deg. C. rated extruded.

Inner sheath should be extruded type and shall be compatible with the insulation provided for the cables.

Outer sheath should be of an extruded type layer of suitable PVC material compatible with the specified ambient temp. 50 deg. C operating temperature of cables. The sheath shall be resistant to water, ultraviolet radiation, fungus, termite and rodent attacks. The color of outer sheath shall be black.

Sequential length marking required at every 1.0 meter interval on outer sheath.

Vendor has to furnish resistance/reactance/capacitance of the cable.



**Rating:**

Up to and including 2200 volts.

## 1. Testing

- **Finished Cable Work At Manufacturer's Works :**

The finished cables shall be tested at manufacturer's works. Following routine test for each and every length of cable and copy of test results shall be furnished for each length of cable along with supply. The cables shall be tested in presence of client's representative.

- Voltage Test :

Each core of the cable shall be tested at room temperature at 3 KV A.C. R. M. S. for a duration of 5 minute.

- Conductor Resistance Test :

The D.C. resistance of each conductor should be measured at room temperature and the result shall be corrected to 20 deg. C. to check the compliance with the values specified in IS: 8130 –1976.

Cable Test Before And After Laying Of Cables At Site: -

- Insulation resistance test between Phases, Phase to Neutral and Phase to Earth.
- Continuity test for all the phases, neutral and earth continuity conductor.
- Sheathing continuity test.
- Earth resistance test of all the phases and neutral.

All tests should be carried out in accordance with relevant Indian Standard Code of practice and Indian Electricity Rules. The vendor shall provide necessary instruments, equipment's, labour for conducting the above test, and bear all expenses in connection with such tests. All test shall be carried out in the presence of the client and result shall be recorded in the prescribe form.

**Cable Marking:**

Embossing On Outer Sheath:

The outer sheath shall be legibly embossed with following legend :

ELECTRIC CABLE: 2200 Volt, Size: 3.5 C \* \_\_\_\_\_ mm<sup>2</sup>. or 3 C \* \_\_\_\_\_ mm<sup>2</sup>

Manufacturer's name and year of manufacturing.

The letter and figures shall be raised and shall consist of upright block characters. The maximum size of the characters shall be 13 mm. And the minimum size 15 % of the cable circumference or 3 mm whichever be the greater. The gap between the end of one set of embossed characters as above and the beginning of the next shall not exceed 150 mm.

Cable length marking at interval of one meter length shall also be embossed/indicated in figures.

**Sealing, Drumming And Packing:**

After test at the manufacturer's works, both ends of the cable shall be sealed to prevent the ingress of moisture during transportation and storage.

The cable ends shall be suitably sealed against entry of moisture, dust, water etc. with cable compound as per standard practice.

All cable shall be adequately protected against any risk of mechanical damage to which they may be liable in normal condition of handling during transportation, loading, unloading etc.

The cable should be supplied in single length i.e. without any intermediate joint or cut unless specifically approved by the client. Cable shall be supplied in length of 500 meters or as required in SINGLE LENGTH in non-returnable drums of sufficiently sturdy construction. Cable of length more than 250 meters shall also be supplied on non-returnable drums.

The spindle hole shall be 220 mm minimum diameter.

Each drum shall bear on the outside flanges, legibly and indelibly in the English literature. A distinguish number, the manufacturer's name and particulars on the cable i.e. voltage grade, length, conductor size, cable type insulation type and gross weight shall also be clearly visible. The direction for rolling shall be indicating by an arrow. The drum flange also be marked with manufacturer's name and year of manufacturing etc.

**Wire & Cables**

The wiring shall be done with single core, FRLS / ZHFR insulated, 650/1100 volt grade, copper conductor wires / cables lay through PVC / Steel conduits as directed. The cables shall conform to IS: 694. The plain annealed copper conductors shall comply with IS: 1554. The FRLS compound shall comply with the requirements of IS: 694. It shall be applied by an extrusion process and shall form a compact homogenous body. Manufacturers name shall be provided throughout the length of cable.

**Following color of wire shall be used for the identification of power circuit.**

Single phase	Red
Three phase	Red, Yellow, Blue
Neutral	Black
Earth	Green

Unless otherwise specified in the drawings the following size of the wire/cables shall be used for internal wiring.

**For the wiring for lights, exhaust fans, ceiling fans, bell, convenience socket outlet points etc.**

From D.B. to switch boards	2.5 mm <sup>2</sup>
From switch boards to Fan / Exhaust Fan points, convenience socket outlet points.	1.0 mm <sup>2</sup>
From switch boards to Light points	1.0 mm <sup>2</sup>
Earth wire switch board to Out let point	0.75/1.0 mm <sup>2</sup>

**For the wiring of power socket outlet having not more than two 15 A power outlets**

From D.B. to first power outlet	4.0 mm <sup>2</sup>
From first power outlet to second power outlet	2.5 mm <sup>2</sup>
power socket outlet circuit having single 15 A power outlet (like water heater)	4.0 mm <sup>2</sup>
Earth wire	14 SWG or 3.0 mm <sup>2</sup>

Separate circuit shall run for each water heater, kitchen equipment, window air conditioner, and similar outlets at location as shown on drawings.

The earth continuity conductor shall be similar to circuit cables and shall be drawn through conduit along with other circuit cables. The size of the earth continuity conductor shall be as follows.

Normal cross-section area of largest associated copper circuit conductor Normal cross-sectional area of earth continuity conductor.

Normal cross-section area of largest associated copper circuit conductor	Normal cross-sectional area of earth continuity conductor.
mm <sup>2</sup>	mm <sup>2</sup>
1.5	1.5
2.5	1.5
4.0	2.5
6.0	2.5
10	6.0

16	6.0
25	16
35	16
50	16

**Bunching Of Cables:**

Unless otherwise specified, insulated conductors of different phases shall be bunched in separate conduit. Wires carrying current shall be so bunched in the conduit that the out going and return wires are drawn into the same conduit. Wires originating from two different phases shall not be run in the same conduit. The number of insulated wires / cables that be drawn into the conduits shall be as per the following table. Maximum permissible number of 650/1100 volt grade single core wire/cables that may be drawn in rigid Steel conduits.

Cable Size	Size of Conduits in mm				
	20	25	32	38	51
mm <sup>2</sup>					
1.5	5	10	14	-	-
2.5	5	8	12	-	-
4.0	3	6	10	-	-
6.0	2	5	8	-	-
10	-	4	7	6	-
16	-	3	5	6	-
25	-	-	3	4	6
35	-	-	2	3	5
50	-	-	-	-	4

**Note:**

If cable size mentioned in the tender is other than the standard size as per IS , next higher size shall be considered.

**Cable Terminations:**

Providing end terminations / cable jointing for cables quantity mentioned in above specification including supply of all jointing materials like glands, cable end sockets, lugs etc. The cable glands shall be of double compression sleeve type and lugs shall be crimping type.

**Terminations:**

Provide Aluminium type connectors or cable lugs crimping / solder type at both ends of the cable. However contractor has to provide Bi-metal washer whenever Aluminium and Copper connection will be made. Dowell's make conductivity grease to be used while using crimping type cable lugs/ sockets. The compression tool shall be equipped with attachment which shall assure proper crimping pressure on the connectors.

Connections shall be made tight and insulated with PVC electrical tape of colour as per I.S.

Terminations of cables shall be done by using kits as recommended by the Engineer-in-Charge taking due care as specified by the manufacturer.

Provide a double compression type cable gland at each end of the cable. Glands should be of nickel-plated brass, with PVC shrouds over it. Before applying a PVC shrouds, all bare metal shall be wrapped with pressure sensitive adhesive tape.

**Saddles and Clips:**

Saddles and Clips shall be PVC covered or of G.I. Fixing screws shall be round head brass, where screws are used. Nuts shall be or brass, square pressed type.

**Jointing Sleeves:**

Jointing sleeves shall be of brass with standard termination. Solder type cable connectors / cable sleeves shall be used to joint the cable / conductors. The Solder used shall comply with B.S. 219 type No corrosive flux only shall be used.

**Transportation And Delivery:**

The cable shall be supplied in the actual length as per joint measured at site.

The cable shall be dispatched at client's stores or at site as per detailed instructions given by client at later stage.

The cable shall be loaded from the main vendor's store and properly stacked as per instruction of client's local repetitive.

**Item No. 144**

**Supplying and erecting approved make Octagonal pole made from HR sheet steel. The pole should be made as per IS. and shall be coated with hot dip galvanizing as per IS 2629/2633/4759, suitable suspend local wind speed with integral Junction box consist of terminal plate of min 6mm Hylam sheet, standard profile 35mmX7.5mm Din-Rail for MCB Mounting, stud type terminal and arrangement for cable termination to be erected With Suitable foundation (Included) as per details given by manufacturer considering site requirement.**

**(D) 6 Mtr. Long 70 mm Top X 135 mm bottom dia, 3 mm thickness with 200mmX200mmX12mm base plate, 4-M20 Bolts and 600mm long J-Bolt. Approx Pole weight 59 Kg.**

**Design :**

The Octagonal Poles shall be designed to withstand the maximum wind speed as per IS 875. The top loading i.e. area and the weight of fixtures are to be considered to calculate maximum deflection of the pole and the same shall meet the requirement of BS: 5649 Part VI 1982.

**Pole Shaft :**

The pole shaft shall have octagonal cross section and shall be continuously tapered with single longitudinal welding. There shall not be any circumferential welding. The welding of pole shaft shall be done by Submerged Arc Welding (SAW) process.

All octagonal pole shafts shall be provided with the rigid flange plate of suitable thickness with provision for fixing 4 foundation bolts. This base plate shall be fillet welded to the pole shaft at two locations i.e. from inside and outside. The welding shall be done as per qualified MMAW process approved by Third Party Inspection agency.

**Door opening:**

The octagonal Poles shall have door of approximate 500 mm length at the elevation of 500 mm from the Base plate. The door shall be vandal resistance and shall be weather proof to ensure safety of inside connections. The door shall be flush with the exterior surface and shall have suitable locking arrangement. There shall also be suitable arrangement for the purpose of earthing. The pole shall be adequately strengthened at the location of the door to compensate for the loss in section.

**Material:**

Octagonal Poles	HT Steel Conforming to grade S355JO.
Base Plate	Fe 410 conforming to IS 226 / IS 2062

Foundation Bolts EN.8 grade

**Welding:**

The welding shall be carried out confirming to approved procedures duly qualified by third party inspection agency. The welders shall also be qualified for welding the octagonal shafts.

**Pole sections:**

The Octagonal Poles shall be in single section. There shall not be any circumferential weld joint.

**Galvanization:**

The poles shall be hot dip galvanized as per IS 2629 / IS 2633 / IS 4759 standards with average coating thickness of 70 micron. The galvanizing shall be done in single dipping.

**Fixing Type:**

The Octagonal Poles shall be bolted on a foundation with a set of four foundation bolts for greater rigidity.

**Top Mountings:**

Decorative bracket arm duly painted and preferably made up of galvanized steel shall be supplied along with the pole for fixing lighting luminaries. Electrical accessories to be mounted inside each pole shall include stud type loop-in-loop out terminals suitable for LT cable and SP MCBs equal to no. of fixtures mounted on the poles.

**Pole Testing Facility:**

The manufacturing unit shall have in-house pole testing facility for validation of structural design data. The pole testing facility shall conform to BS EN 40-3-2-2000 part 3-2.

**Manufacturing Unit:**

The pole / bracket manufacturing & galvanizing unit shall be preferably ISO 9001: 2000 & ISO 14001 certified to ensure consistent quality & environmental protection.

**Street Light Fitting :**

120 watt LED street light luminaire, Pressure die-cast aluminium alloy for housing, IP65 protection, In-built electronic driver with APFC, THD

**A The LED Luminaries are as per the following parameters**

- a Mid Power White LED's Should be of reputed make as indicated in the Tender specification.
- b Wattage of Mid Power White LED,s offered Low power LED 5252 0.3W
- c LED Lumens
- d Life span as per LM70( @70%) light output >50000 Hrs. Or Better
- e Lux at centre at height of 4.5 mete >150 LUX Or Better
- f Uniformity Ratio(Emin./Emax.)( mounted at 4.5m height @90 Ångle) >0.35 Or Better
- g Luminary Efficacy >65 Or Better
- h Control of Distribution Fully Cutoff
- i Driver current(With Constant Current Driver) <100mA/LED Or Better
- j Electronic Efficiency@230V>85% Or Better
- k Beam angle of the Luminary > 120° Or Better
- l color Temperature of LEDs 6500K to 7500K Or Better
- m P/N junction temperature (High thermal conduction must be achieved by silicon heat conducting greases as adhesive <85 °C Or Better
- n Luminary Body Temperature The Body Temperature shall be <(Ambient+35° C) even after continuous burning of Luminary for 24 Hrs.Or Better
- o color Rendering Index(CRI) >70 Or Better
- p weight Preferably less weight & may be of Maximum up to 4 Kgs (comfortably can be carried and fixed)

**B ELECTRICAL**

- a AC Input Voltage Range 100V TO 270V AC

- b AC Input frequency .( The LED circuitry shall function at an operating frequency that must be greater than 120 Hz to prevent perceptible flicker to the unaided eye over the entire voltage range specified above.  
 ) 47 ~ 53Hz
- c Power Factor (Source Power Factor varies from 0.5 Lag to 0.5 Lead) > 0.95 Or Better
- d Luminary Wattage variance at 100 V to 270V ± 10%
- e Luminary Lux Levels Variance at 100 V to 270 V ± 5%
- f Total Harmonic Distortion(THD) < 15% Or Better
- g Electrical Connection System 3 wire system (Phase, Neutral & Gnd)
- h System of earthing (The luminaries offered shall conform to Level-1 classification) Solidly grounded
- i There shall be electrical isolation between input and output circuits of the driver.

### C MECHANICAL

- a Construction of Casing High Pressure Die Cast Aluminum. Should be durable for extreme climatic
- b Finish Powder Coating and gray/black color and should be durable. The colour should not fade in extreme climate conditions.
- c Heat Sink type (It shall be designed in such a way that the heat generated within the LED source is efficiently dissipated to the surrounding atmosphere without abnormal rise in temperature. Any debris build up shall not degrade heat dissipation performance of the luminaries. Aluminium Metal Core PCB
- d Lamp Cover Toughened Glass or any suitable material which can be used in the extreme climate and should be durable.
- e Gross Weight and Dimensions (L x W x T) mm of Luminaries (Efforts shall be made to keep the overall outer dimensions as minimum as possible with out compromising on the performance, mainly thermal management of the luminary )
- f Heat Dissipating Area (Luminary Rating wise)
- g IP Level –Minimum IP 65

### Installation of Poles:

Installation of poles shall be done as per design and drawing. Foundation drawing shall submitted for AMD's approval.

RCC pedestal using M-20 grade concrete ,tor steel shuttering etc are envisaged ,scope also includes supply and embedment of 1 nos -100 mm dia bent GI pipes for taking cables . The other consumable required to complete the job in all respects is in contractor's scope.

The Contractor shall make his own arrangements for moving / lifting all the equipments / items to the respective erection sites.

The equipments /items shall be installed in a neat work manner so that it is leveled, plumbed, squared and properly aligned & oriented.

The Contractor shall furnish all supervision, labour, tools, equipments, rigging material, incidental items such as bolts, wedges, anchors / angles, frames, studs, raw plug, concrete etc. to complete the installation. Manufacturer's drawings, instructions and recommendations shall be correctly followed in handling, installing, testing and commissioning of all items / equipments.

The Contractor shall carry out civil works, welding, bolting, drilling, grouting, chipping, sealing, making opening, finishing etc. as required for satisfactory execution of the work.

All care should be taken to avoid damage to galvanized / painted surfaces during installation. Damages, if any, shall be properly repaired using cold spray zinc solution / paint as the case may be.

All nuts, bolts and washers required for complete installation shall be zinc plated / hot dip galvanized.

Excavation in all types of soil, casting of civil foundation & grouting of foundation bolts, its curing, back filling & making the surface good and cleaning etc. are included in the scope of civil work related to poles.

### INSTALLATION OF STREET LIGHT FIXTURES :

This includes fixing of street light fitting complete with accessories and lamps at the end of the pole/bracket, connecting it with designed capacity and size copper conductor, PVC insulated cable from terminal block mounted in bottom of pole, testing and commissioning. The third core shall be connected to earth point of pole.

**EARTHING SYSTEM:**

All equipment of the lighting system shall be earthed as per relevant Indian Standards.

**General**

specifications of earthing for pole is given below.

Each pole shall be earthed using 1 no. 20mm dia., 1.5 m long MS rod. The connections between the earthing stud inside pole and the electrode shall be done with 8 SWG GI wire

**Steel Structure Items:**

Drawings shall be given to successful tenderer after award of P.O. TECHNICAL SPECIFICATION FOR LED FLOOD / NORMAL LIGHT FITTINGS 1 PH A.C OPERATION

**GENERAL DESCRIPTION:**

LED Flood/Normal Light luminaries of 240V, A.C,50 Hz ,suitably decided the wattage of the lamp (to be decided after detail Engineering) in Single piece High Pressure Die Cast Aluminium alloy Housing having high conductivity acting as heat sink, with Powder coating with suitable colour with distortion free, clear, Heat Resistant Toughened UV stabilized Glass in the front fixed to the die cast Aluminium frame which shall be fixed to the housing with high quality long lasting Neoprene Rubber gasket duly impregnated with insecticide and water repellent chemical on the periphery of lamp compartment by means of stainless steel screws to render it dust proof, water proof and vermin proof and having minimum IP-65 Protection conforming to IS:10322 (part-2) – 1982.

**Item No. 145**

**Providing and erecting street light pole bracket comprising main B Class GI pipe of 4.2 cm/require outside dia. complete with suitable B Class G.I sleeve tubing of approx. 45cms.length and suitable for 76.5 mm / 80mm. / require size pole top having sufficient fasteners for fixing the brackets and having spread of 1 mtr. length with suitable rise as per site condition & suitable welded stiffener reducer and nipple with check nut complete painted with one coat of Red oxide / PU base primer and two coats of Aluminium / PU paint. paint with following nos of arms.**

**[A] Single Arm bracket 1 Mtr**

SUPPLY, ERECTION AND COMMISSIONING OF DETACHABLE BRACKETS: -

- (a) Single arm 1.0 m
- (b) Double arm 1.0 m
- (c) Triple arm 1.0 m
- (d) Single arm 1.5 m
- (e) Double arm 1.5 m
- (f) Triple arm 1.5 m

Providing Street Light pole bracket consisting of medium class MS pipe of 4.2 cms. Outside dia 2.9 W.T complete with suitable sleeve tubing (If required) 45 cms. long M.S. pipe (Medium Class). Suitable for 76.5 mm /80mm / required size of pole top/ Wall mounting having sufficient fasteners for fixing the brackets and having spread as mentioned and having inclination up to 115 deg. with vertical plane & suitable welded stays, reducer and with check nuts complete painted with one coat of Red oxide / PU base primer and two coats of Aluminium / PU paint. paint with required nos of arms.The bracket shall be hot dip galvanized as per IS 2629/IS 2633/IS 4759 standards.

**Item No. 146**

**Supplying, erecting, testing, commissioning approved make M.S. Polygonal High Mast Pole having following general Specification.**

**(a) Polygonal Section fabricated from M.S. Plate confirms BSEN 10025 & Hot deep galvanized minimum 65/86 micron (as per IS 2629 /1985) Lantern carriage with ring and rubber lines for erection of luminaries of suitable site.**

**(b) Maximum telescopic section not more than four**

**(c) Double drum gear pipe motorized winch with 6mm dia S.S. Rod (For 16 mtr and above size)**

**(d) Approved make L.E.D. aviation light = 1 No. Lightning arrestor = 1 No. with necessary wiring of 2.5 sq.mm 5 core ISI copper cable Unarmoured.**

**(e) Bottom most section suitable for mounting reversible motor and switchgears having door not more than 1400mm x 300mm with waterproof gasket & hinges & locking arrangement.**

**(f) Pole structure comprises suitable size of reversible motor, cable and necessary switchgears with control panel.**

**(g) bottom section shall have suitable size of thickness supports ribs foundation bolts nuts etc.**

**(h) Item not comprises the cost of lanterns.**

**(i) Necessary Cement Concrete foundation as per IS including testing & commissioning of the entire structure for following size of High Mast poles**

**[7] High Mast 20 Mtr. TOP A/F 150 Mm, BOTTOM A/F 400 Mm, No. of Sec. No. - 2, Bottom Thickness - 4 mm, Top Sec. - 3 mm, Size Base Plate -dia.580 mm x 20 mm thick, Foundation Bolt Size M27 x 850mm , Qty - 10 Nos., Suitable for mounting Fitting of Light - 12 Nos.**

#### **SCOPE OF SUPPLY**

The scope of supply is defined in detail under the scheduled of quantities and technical specifications. The various material covered under the scope of this tender are detailed below. The vendor is required to carry out any other scope as per the site requirement within the items available under this tender. 1. High mast lighting system of 20 mtrs high with its accessories. Mast shaft shall be in three sections. 2. Foundation bolts special steel along with nuts, washer anchor plate and templates plates for high mast.

3. 250Watt LED floodlights luminaries fittings completed with its accessories will be fitted on each high mast 12 nos,

4. Twin dome aviation obstruction light with 2 nos. 100W (approx) LED lamp.

5. Outdoor type feeder pilla and Control panel for operation of the high mast with 63 amp, 4 pole MCCB, timer & contactor.

**1. HIGH MAST LIGHTING SYSTEM OF 20 MTRS HIGH WITH ITS ACCESSORIES. MAST SHAFT SHALL BE IN THREE SECTIONS. HIGH MAST:**

a) The lighting mast shall be of continuously tapered polygonal cross section hot dip galvanized fabricated from special steel confirming to IS- 2629. The mast shall be of height 20 meter (minimum) with lantern carriage to enable raising and lowering for ease of maintenance, including the dead frame, double drum winch, continuous stainless steel wire rope, In built power supply tool, luminaries, suitable aviation warning light, lightning protection electrode, Necessary cables and wiring accessories etc as required to complete the work in totally.

b) The mast shall be delivered only in three sections and shall be joined together by slip stress fit method at site. No site welding or bolting joints shall be done on the mast. The minimum overlap distance shall be 1.5 times the diameter at penetration.

c) Lantern carriage shall be fabricated suitably and hot dip galvanized for fixing and holding LED flood light fixtures and their accessories, Lantern carriage shall be provided with 12 nos., 1 x 250W LED flood light fixtures.



d) Junction box if any shall be weather proof conforming to IP: 55 protection class made of cast aluminium and mounted on the carriage to facilitate interconnection of light luminaries.

**STRUCTURE:**

The High mast shall be of continuously tapered, polygonal cross section, twenty (20) sided (indicative), presenting a good and pleasing appearance and shall be based on proven In-Tension design conforming to the standards referred to above, to give an assured performance, and reliable service. The structure shall be suitable for wind loading as per IS 875, part-3 (1987).

**CONSTRUCTION:**

The mast shall be manufactured using special steel plates, conforming to BS-EN10-025/ IS 2062 and shall be delivered in multiple sections of effective length 8.8mtr(approx) meters. Thus a 20 m mast shall be delivered in three sections to site. Each section shall be fabricated out of single plate duly folded and welded. There shall be only one longitudinal seam weld per section. Section with more than one weld, circumferential or longitudinal, shall not be accepted. At site the sections shall be joined together by slip-stressed-fit method. No site welding or bolted joint shall be done on the mast. The minimum overlap distance shall be 1.5 times the diameter at penetration. The minimum top & bottom diameter shall be as per the relevant IS-1944(Part-V)-1981. Plate thickness shall be as per the structural requirements. Detailed design calculation of the mast shall be submitted for verification. The mast shall be provided with fully penetrated flange, which shall be free from any lamination or incursion. The welded connection of the base flange shall be fully developed to the strength of the entire section. The base flange shall be provided with supplementary gussets between the blowholes to ensure of helical stress concentration. For the environmental protection of the mast, the entire fabricated mast shall be hot dip galvanized, internally and externally, having a uniform average thickness of 610gm/sq.mtr. for foundation bolts/plate/structures. Galvanizing shall be done in single dipping method for better adhesion and life.

**DOOR OPENING:**

An adequate door opening shall be provided at the base of the mast and the opening shall be such that it permits clear access to equipment like winches, cables, plug and socket, etc. and also facilitate easy removal of the winch. The door opening shall be complete with a close fitting, vandal resistant, weatherproof door, provided with a heavy-duty double internal lock with special paddle key. The door opening shall be carefully designed and reinforced with welded steel section, so that the mast section at the base shall be unaffected and undue buckling of the cut portion is prevented. Door panel shall be made of 14SWG CRCA sheet metal. The distance from the mast flange plate to the bottom of door opening shall be minimum of twice the width of the door opening to avoid buckling of the mast section under heavy wind conditions.

**DYNAMIC LOADING FOR THE MAST:**

The mast structure shall be suitable to sustain an assumed maximum reaction arising from a wind speed as per IS 875(Part 3)-1987 (three second gust), and shall be measured at a height of 10 meters above ground level. The design life of mast shall be minimum 25 years.

**LANTERN CARRIAGE:**

A fabricated Lantern Carriage shall be provided for fixing and holding the flood light fittings, accessories and junction boxes. The Lantern Carriage shall be of special design and shall be of steel tube construction, the tubes acting as conduits for wires, with holes fully protected by grommets. The Lantern Carriage shall be so designed and fabricated to hold the required number of flood light fittings, accessories and JB's, and also have a perfect self balance and shall have proper arrangement to avoid swing. The Lantern Carriage shall be fabricated in two halves and joined by bolted flanges with stainless steel bolts and nylon type

stainless steel nuts to enable easy installation or removal from the erected mast. The inner lining of the carriage shall be provided with protective PVC arrangement, so that no damage is caused to the surface of the mast during the raising and lowering operation of the carriage. The entire Lantern Carriage shall be hot dip galvanized after fabrication. Lantern Carriage/Accessories shall be made with best steel in compliance with BSEN 10025 FE430A or better.

**JUNCTION BOX:**

Weather proof junction box of IP 55, made of Cast Aluminium shall be provided on the Carriage Assembly as required, from which the inter-connections to the designed number of the flood light luminaries and accessories fixed on the carriage shall be made.

**RAISING AND LOWERING MECHANISM:**

For the installation and maintenance of the luminaries etc, it will be necessary to lower and raise the Lantern Carriage Assembly. To enable this, a suitable Winch Arrangement shall be provided, with the winch fixed at the base of the mast and the specially designed head frame assembly at the top. The lantern carriage assembly shall reach 1 M from the base of the mast for easy access. There shall be provision to disconnect the main trailing cable going to Lantern carriage before starting to lowering mechanism.

**WINCH:**

The winch shall be of completely self sustaining type, without the need for brake shoes, springs or clutches. Each driving spindle of the winch shall be positively locked when not in use by gravity activated PAWLS. Individual drum also should be operated for fine adjustment of lantern carriage. The capacity, operating speed, safe working load, recommended lubrication and serial number of the winch shall be clearly marked on each winch. The average rate of raising and lowering shall be not less than 3 meters per minute. Initial supply of oil for winch shall be given by the party. The gear ratio of the winch shall be 53: 1(indicative)) The minimum working load shall be not less than 750 kg. The winch shall be self-lubricating type by means of an oil bath and the oil shall be readily available grades of reputed producers. The winch drums shall be grooved to ensure perfect seat for stable and tidy rope lay, with no chances of rope slippage. The rope termination in the winch shall be such that distortion or twisting is eliminated and at least 5 to 6turns of rope remains on the drum even when the lantern carriage is fully lowered and rested on the rest pads. It should be possible to operate the winch manually by a suitable handle by an integral power tool. It shall be possible to remove the double drum after dismantling, through the door opening provided at the base of the mast. Also, a winch gear box for simultaneous and reversible operation of the double drum winch shall be provided as part of the contract. The winch shall be type tested in presence of a reputed Institution and the test certificates shall be furnished before supply of materials. A test certificate shall be furnished by the agency from the original maximum load operated by the winch.

**HEAD FRAME:**

The head frame, which is to be designed as a capping unit of the mast, shall be of welded steel construction, galvanized both internally and externally after assembly. The top pulley shall be of appropriate diameter, large enough to accommodate the stainless steel wire ropes and the multi-core electric cable. The pulley block shall be made of non-corrodible material, and shall be of die cast Aluminium Alloy (LM-6). Pulleys made of synthetic materials such as Plastic or PVC is not acceptable. Self-lubricating bearings and stainless steel shaft shall be provided to facilitate smooth and maintenance free operation for a long period. The pulley assembly shall be fully protected by a canopy galvanized internally and externally. Close fitting guides and sleeves shall be provided to ensure that the ropes and cables do not dislodged from their respective positions in the grooves. The head frame shall be provided with guides and stops with PVC buffer for docking the lantern carriage.

**STAINLESS STEEL WIRE ROPES:**

The suspension system shall essentially be without any intermediate joint and shall consist of only non-corrodible stainless steel of AISI 316 or better grade. The stainless steel wire ropes shall be of 7/19 construction, the central core being of the same material. The overall diameter of the rope shall not be less than 6 mm. The breaking load of each rope shall not be less than 1800 kg(approx) giving a factor of safety of over 5 for the system at full load as per the TR-7 standards. The end constructions of ropes to the TR-7 standards. The end constructions of ropes to the winch drum shall be fitted with earth. The thimbles shall be secured on ropes by compression splices. Three continuous lengths of stainless steel wire ropes shall be used in the system and no intermediate joints are acceptable in view of the required safety. No intermediate joints/terminations, either bolted or else, shall be provided on the wire ropes between winch and lantern carriage. Rope shall be tested at govt. approved laboratory and having accreditation of NABL.

**POWER TOOL FOR THE WINCH:**

A suitable, high-powered, electrically driven, internally mounted power tool, with manual over ride shall be provided to (operate the winch) raising and lowering of the lantern carriage for maintenance purposes. The speed of the power tool shall be to suit the system. The power tool shall be single speed, provided with a motor of the required rating and make. The power tool mounting shall be so designed that it will be not only self supporting but also aligns the power tool perfectly with respect to the winch spindle during the operations. Also, a handle for the manual operation of the winches in case of problems with the electrically operated tool shall be provided and shall incorporate a torque limiting device. The winch drive unit shall be squirrel cage reversible induction motor with following characteristic: 415V, 3 phases, 50 HZ, Class F insulation, Weather resistant, IP55, Protections, Make: Compton Greaves/Kirloskar/Siemens/ABB/ALSTOM/Bharat Bijlee make of suitable power rating and RPM. There shall be a separate torque-limiting device to protect the wire ropes from over stretching. It shall be mechanical with suitable load adjusting device. The torque limiter shall trip the load when it exceeds the adjusted limits. There shall be suitable provision for warning the operator once the load is tripped off. The torque limiter is a requirement as per the relevant standards in view of the overall safety of the system. Lighting mast shall have its own power tool motor.

**ELECTRICAL SYSTEM, CABLE AND CABLE CONNECTIONS:**

A suitable terminal box shall be provided as part of the contract at the base compartment of the high mast for terminating the incoming cable. The electrical connections from the bottom to the top shall be made by special trailing cables. The cable shall be EPR insulated and PCP sheathed to get flexibility and endurance. The min. Size of cable shall be minimum 5 cores 4 sq mm copper. The cable shall be of Finolex/Polycab/Havells /KEI/KEC/MESCAB make. This is special cable made for the raising lowering operation of cable over pulleys at the top there shall be weather proof junction box to terminate the trailing cable. Connections from the top junction box to the individual.

Luminaries shall be made by using 3 core 2.5 sq. mm flexible PVC cables of make as stated above. The system shall have in-built facilities for testing the luminaries while in lowered position. Also, suitable provision shall be made at the base compartment of the mast to facilitate the operation of internally mounted, electrically operated power tool for raising and lowering of the lantern carriage assembly. The trailing cables of the lantern carriage rings shall be terminated by means of suitably designed, metal clad, multi pin plug and socket provided in the base compartment to enable easy disconnection when required.

**EARTHING SYSTEM:**

Two nos. G.I. Pipe earthing for each high mast. The earth electrode shall be perforated heavy gauge GI pipe, 50mm dia with 4mm thickness and 3 meter length in one piece. The earth pit consists of GI Earth Electrode, with alternate layer of salt and charcoal or chemical earth pit. Earth pit top shall have dimension of 30cm x 30cm and 50 cm high pre cast concrete chamber. Each Earth pits shall be interconnected using 25x6mm GI flat. The Earth Resistance value should not more than 2.0 ohms.

**FOUNDATION BOLTS:**

Foundation bolts, special steel along with nuts, washer anchor plate and templates plates shall be supplied as per design for high mast and conforming to BS-EN 10025/ IS 2062.

**LED FLOODLIGHT:**

LUMINARIES FITTINGS WITH 1 NOS 250W LED COMPLETED WITH ITS ACCESSORIES (includes lighting protection):12 nos. will be fitted on each high mast (12 nos.). Long range, high intensity, energy saving flood light fittings with LED shall be provided. The Luminaries should be dust, moisture and vermin proof. The fitting should be complete with highly polished stainless steel mirror reflector- cum – body, pilfer proof and captive bolting system duly incorporated vibration isolators, toughened front glass of min 5 mm thickness, focusing arrangement, neoprene rubber gaskets and steel inserts at threaded portions. The LED must have power factor $\geq$ 0.95, CRI $\geq$ 80, CCT $\geq$ 5700K $\pm$ 10%, system efficacy $\geq$ 100lumen/W. The fittings offered should have type test certificate including for photometry for all tests specified in the type test clause and also for wind load test and leakage current test from a NABL (National Accreditation Bureau of Laboratories) approved Government Test House. Luminaries shall be specially designed; degree of protection of the light fitting shall be IP65, Make Philips/Crompton Greaves/ Bajaj Electricals/ GE/ Havells/Orient. The luminaries shall be tested as per Indian standards and test reports shall be submitted along with the materials. The luminaries shall be suitable for installation on high masts.

**LIGHTNING FINIAL:-**

Heavy duty hot dip galvanized lighting finial shall be provided at the Centre of the head frame as per IS-2309. The lighting finial should be insulated with high mast and a separate cable of 16 sq mm copper flexible cable shall be provided to connect directly to the earth pit. Supply of 16 sq mm flexible copper cable is in the scope of party. The lighting finial should not be provided on the lantern carriage under any circumstances in view of the safety of the system.

**AVIATION OBSTRUCTION LIGHTS:-**

Suitable Aviation Obstruction Lights shall be provided on top of each mast. Led lamp 2nos, 100watt aviation obstruction light fitted in a weather- proof box on body unit of Aluminium alloy shall be supplied. The cover of the light will be glass with rubber gasket (IP65 protection)

**CONTROL PANEL OF THE HIGH MAST WITH ALL ACCESSORIES SUCH AS 63 AMP, 4 Pole MCCB, TIMER & CONTACTOR ETC:-**

Lockable feeder pillar box with ingress protection IP-65 made of 14 SWG CRCA sheet metal(850 mm HeightX500mm Breath X 400 Depth), self supporting, Floor mounted, dust, vermin and weather proof for outdoor use shall be supplied for locally/automatically switching' ON/OFF of luminaries & operation of winch motor. The control panel comprises the following:

- a) 63 Amps, 4 Pole MCCB for incomer power, Make: ABB/L&T/Siemens/SCHNEIDER.
- b) 32Amps TPN fuse switch unit as isolator for motor, Make: ABB/L&T/Siemens/SCHNEIDER.
- c) Earth leakage Relay with core balance transformer, Sensitivity: 30 MA to 2A, Time delay: 0 – 2 sec., Make: SCHNEIDER/ MDS Legrand/L&T/SIEMENS/ABB.

- d) 32 Amps triple pole AC 3 duty power contactor for lighting circuit, coil Voltage: 230VAC+/-10%, Make: ABB/L&T/Siemens/SCHNEIDER.
- e) Start/Stop push button for locally switching ON/OFF the luminaries – 1 set. NS type fuses carrier and base for control circuit. (Start/stop PB make:- Schneider Electric, L&T, Siemens and Fuse carrier and Fuse make:- GE,L&T,Siemens,CGL)
- f) Automatic lighting Switch with digital time switch of rail mounting suitable for astronomical calculations of sun rise and sun set by setting date, time and positions of longitude and latitude, asrtotime –switch, 230V AC, 50HZ.(Make-EAPL, Siemens, BCH,L&T and GE.
- g) 2Nos hoisting duty contactor for forward and reversing operation of motor along with Push buttons, LED indication lamps, other requisite switchgears for motor operation. (Contactor Make:- ABB/L&T/Siemens/SCHNEIDER)
- h) Detachable gland plate and nut-bolt type terminal blocks for incoming and outgoing cable connections.
- i) Feeder Pillar box to be painted with by 2 coats of primer followed by epoxy grey paint of shade RAL-7035.
- j) Push button for raising and lowering the mobile part shall operate on "Dead man principal" i.e. action shall cease as soon as the button is released.
- k) Single line diagram of electrical circuit to be shown on inner surface of the door of Feeder pillar box. l) A single line diagram along with control and power circuit for Feeder Pillar shall be submitted along with the offer.

#### **INSPECTION, TESTING AND ACCEPTANCE OF WORKS:-**

- a. All equipment to be supplied shall be of type tested design. During detail engineering, the contractor shall submit for Owner's approval the reports of all the type tests as listed in this specification and carried out within last Ten years from the date of bid opening. These reports should be for the test conducted on the equipment similar to those proposed to be supplied under this contract and the test(s) should have been either conducted at an independent Government approved laboratory or should have been witnessed by a client.
- b. However if the contractor is not able to submit report of the type test(s) conducted within Ten years from the date of bid opening, or in the case of type test report(s) are not found to be meeting the specification requirements, the contractor shall conduct all such tests under this contract at no additional cost to the owner either at Government approved laboratory in presence of client/owners representative and submit the reports for approval.
- c. All acceptance and routine tests will be carried out as per approved QP. Reference QP is enclosed; however final QP will be approved after placement of the PO. Charges for these shall be deemed to be included in the equipment price. d. Selection of samples for type test, routine test and acceptance criteria for all the items shall be as per relevant I.S e. Type test reports of the following items as per technical specification requirements/ standards shall be submitted for approval.

#### **SL NO. DESCRIPTION**

- 1) Lighting fixtures of each type
- 2) LEDs of each type and rating. (Life cycle and rating test only)
- 3) Lighting panel of each type (Degree of Protection)
- 4) Junction Box of each type

#### **Acceptance Test and Routine Test:-**

- a. All lighting fixtures, lamps and other items shall be subjected to acceptance and routine test, as per approved QP as mentioned below:-

- b. Junction boxes, switch boxes, receptacle enclosure etc. shall be subjected to physical and dimensional checks.
- c. Mechanical operation of the lantern carriage.
- d. Load carrying capacity test
- e. Operation of winch for over speeding/time to raise and lower
- f. Visual check of positive locking arrangement of winch system
- g. Test of operation electrically and manually
- h. Test of power tool as per relevant standards
- i. Test of all protection, alarm and trip functions
- j. Check degree of protection of cubicles

**Galvanizing Tests:-**

The quality of galvanizing shall be smooth, continuous, and free from flux stains and shall be inspected visually. In addition following tests shall be conducted as acceptance tests.

(a.) Uniformity of coating - The coating of any article shall withstand four 1minute dips in standard copper sulphate solution without the formation of an adherent red spot of metallic copper upon the basic metal.

(b.) The quality of cadmium/zinc plating on items with screw threads shall be free from visible defects such as unplated areas, blisters and modules and shall be inspected visually.

In addition, the plating thickness shall be determined microscopically/chemically or electronically.

**B) FOUNDATION, ERECTION, INSTALLATION AND COMMISSIONING OF 20 MTRS HIGH MAST SCOPE OF WORK:-**

**1. DESIGN,SUPPLY AND CASTING OF SUITABLE SHALLOW FOUNDATION WITH MINIMUM M-25 GRADE CONCRETE FOR THE HIGH MAST CONSIDERING SAFE SOIL BEARING CAPACITY AT SITE AS 10 T/ SQ.MTR AT 2M DEPTH WITH ALL LABOUR AND MATERIALS.**

**CIVIL STRUCTURAL WORKS**

**Scope of work:**

Design and casting of suitable RCC foundation for 4 nos. High Mast. This includes total civil jobs including earth work and de-watering if required. After completion of job surplus earth shall have to be removed (All kinds of civil materials needed for execution of this job shall have to be arranged by the agency at their own cost & responsibility).

The scope of work under this specification includes design, detailing, supply & construction of foundation for high mast works. The work shall in general be executed as per IS: 456 and shall referred therein.

**Materials:**

**Cement:**

The cement used shall be any of the following unless otherwise specified in project data sheet:

- 1.33 grade ordinary Portland cement conforming to IS:269
- 2.43 grade ordinary Portland cement conforming to IS:8112
- 3.Portland slag cement conforming to IS:455
- 4. Sulphate resisting Portland cement conforming to IS:12330.

**Aggregate:**

The aggregate used shall be any of the following unless otherwise specified in project data sheet 1. Only natural existing aggregates conforming to IS:383 2. Coarse aggregate shall be 20mm downgrades as per

IS:383 3. Fine aggregate shall be graded evenly as per Zones II and III of IS: 383. Zone IV aggregate shall not be used.

**Water:**

Water used for manufacture and curing shall be clean and free from injurious amount of oil, acids, alkalis, salts, sugars, organic materials or other substances that may be deleterious to concrete or steel as specified in IS:456. Potable water shall be considered suitable.

Reinforcing Steel: Only high strength deformed steel bars of grade Fe-450/500 conforming to IS: 1786 shall be used.

**FOUNDATION WORKS:**

Suitable foundations shall be designed & constructed. The successful bidder shall submit the drawing of foundation and QAP for approval within 10 days from the placement of PO. The excavation of the earth for foundation shall be the contractor's responsibility. The excavated materials and unwanted materials shall be cleared then and there and dumped away from the site locations as per the EIC. Accordingly RCC concrete foundation shall be provided. The agency shall supply of all materials like blue metal, sand, steel, cement etc., and chipping, cutting, plastering etc. and back filling of up to the normal ground level of the adjoining area.

The provision of foundation shall be excavated well in advance and sufficient curing shall be given after completion of concrete works.

The top level of the concrete base shall be higher than adjacent ground level by not less than 50 cm.

**2.ERECTION OF HIGH MAST SYSTEM COMPRISING OF MAST AND ACCESSORIES,AVIATION WARNING LAMP, LUMINAIRES (INCLUDING WIRING,EXTERNAL POWER CABLE LAYING FROM SOURCE TO FEEDER PANEL),ETC WITH THE HELP OF SUITABLE EQUIPMENTS WITH ALL MATERIALS AND LABOUR.**

- a) Erection of High mast on the foundation with the help of suitable equipments.
- b) Wiring & installation of luminaries with all accessories. The electrical installation shall comply with all appropriate statutory requirements.
- c) Installation of lightning arrester & aviation light

**3. PROVIDING 2 NOS. EARTH PIT FOR EACH HIGH MAST OF GI PIPE EARTHING 3.0 MTRS LONG 50MM DIA PIPE INCLUDING CONNECTION OF HM AND EARTH TERMINALS WITH 25 X6MM GI FLAT WITH ALL MATERIALS AND LABOUR.**

a) Construction of Pipe Earthing Installation as per IS: 3043/1987. The Earth Electrode shall be of perforated heavy gauge GI Pipe, 50 mm dia with 4mm thickness and 3 Mtr length in one piece. The Earth Pit shall consist of GI Earth Electrode, with alternate layer of salt and charcoal. Earth Pit top shall have a dimension of 30cmx30cm and 50cm high precast concrete chamber. Each Earth Pits shall be interconnected using 25x6 MM GI Flat. ER value should not more than 2.0 ohms.

b) All other connections to high mast tower, feeder pillar box etc will be connected with 25 X 6 mm 2 Nos. of G.I. Flat.

**4. ERECTION OF FEEDER PILLAR.**

- a) Erection of MCC/Feeder panel on suitable foundation including all materials. Installation of mast feeder pillar by grouting stand on the concrete with all material and labours.
- b) Cable terminations as per standards and cable laying from LDB MCC to high mast feeder as per the route. The agency shall do the necessary arrangement for identification of cable by providing the proper cable tag

and also mark incoming and outgoing legends suitably on the feeder. Sign posts to be erected along the cable route to enable its easy tracking if required.

c) The agency shall provide Earthing to lighting mast & Feeder pillar panel as per IS- 3043. The agency has to arrange earth flats and all the required materials.

d) The agency shall do the testing and commissioning of the cable, high mast towers as per the relevant standard and direction of client.

#### **Item No. 147 & 148**

**Supplying and erecting LED street light / Flood light fittings with High power White LEDs wattage of 3 Watt and above assembled on single MCPCB, efficiency more than 130 lm/w and corrosion free High pressure die cast aluminum housing with smooth finish powder coated and heat sink extruded aluminium with diffuser and Polycarbonate optics/ lenses, with toughened glass with company mark/name engraved or embossed 160 to 270 V, Power Factor more than 0.95, THD < 10 %, CCT 3000 K to 5700K, Uniformity ratio >0.45, Luminaire efficacy > 100 lumens/watt . LED driver efficiency > 85 %.( fittings required LM-79 & LM-80 certificates)(NOTE: Below description have shown ranges of Wattage capacity of LED fittings. The Engineer incharge may select any wattage capacity between the ranges shown.)**

**(A) Street Light (IP-65), Surge protection -4KV integral and ,Light must have 440VAC line supply with over-voltage protection.**

**(iii) Above 60 to 90 watts Cat III**

**(vii) Above 200 to 250 watts Cat III**

**SUPPLY, LAYING, TESTING AND CONNECTING UNARMoured CABLE:**

The item includes supply, laying, testing and commissioning of round 3 X 1.5 sq. mm for LED luminaries flexible unarmoured single PVC insulated copper conductor cable 1100 V grade to be laid through the pole from luminaries to junction box by experienced technician without any damage. The cable joint shall not be allowed. Termination glands/lugs etc shall be included in the item.

**SITC OF LED LIGHT LUMINAIRES:-**

**TECHNICAL SPECIFICATION FOR ENERGY EFFICIENT LED BASED LUMINAIRE UNIT FOR LED LIGHT: -**

This specification is for technical and general requirements design, development, manufacturing, testing and supply of energy efficient LED luminary complete with all accessories, LED lamps with suitable current control driver circuit and required optics including mounting arrangement.

**CODES & STANDARDS: -**

IEC 60529 Classification of degree of protections provided by enclosures (IP Codes)

EN 55015, CISPR15 Limits and methods of measurement of radio disturbance characteristic of electrical lighting and similar equipment.

IEC 62031 LED modules for general lighting-Safety requirements

IEC 61547-EMC Immunity requirement

IEC 60598-2-1 Fixed general purpose luminaries

IEC 60598-1 Luminaries - General requirement and tests

IEC 61000-3-2 Electro Magnetic compatibility (EMC)- Limits for Harmonic current emission -- (equipment input current  $\leq$  16 A per phase.

IEC 60068-2-38 Environmental Testing: Test Z- AD: composite temperature/ humidity cyclic test

IEC 61347-2-13 Lamp control gear: particular requirements for DC or AC supplied electronic control gear for LED modules.

IS 10322 Specification for the luminaries

IS 4905 Method for random sampling



LM 79 LED luminary photometry measurement.

LM 80 Lumen Maintenance

IEC 62384 DC or AC supplied electronic control gear for LED modules performance requirements

IEC/ PAS 62612 Self-ballasted LED lamps for general lighting services- Performance requirements

CONSTRUCTIONAL FEATURES:

General:

a) Luminaries shall be made of die cast aluminium/ extruded Aluminium body with powder coated finish having safety.

b) Heat sink used should be aluminium extrusion having high conductivity. Heat sink should be integrated within luminaries and efforts shall be made to keep the overall outer dimensions

c) optimum such that it permits sufficient heat dissipation through the body itself so as to prevent abnormal temperature inside the luminaries and consequential damage to cover, gasket material, LEDs, lenses and drivers.

d) LED must be mounted on Metal core PCB with suitable large area surface by means of fins to dissipate the conduct heat. The fins must be exposed to ambient flowing air.

e) All luminaries shall be provided with toughened glass of min. 0.8 mm thickness of sufficient strength. UV stabilized Poly carbonate material is also acceptable. High efficiency prismatic diffuser/Lens under the LED chamber to protect the LED and luminaries shall be provided.

f) The minimum IK protection of optic cover shall be IK 05. The test material certificate shall be provided.

g) Suitable number of LED lamps shall be used in the luminaries. The manufacturer shall submit the proof of procurement of LEDs from OEMs at the time of testing.

h) Suitable reflector/ lenses may also be provided to increase the illumination uniformity and distribution.

i) The electrical component of the LED and LED driver must be suitably enclosed in sealed unit to function in environment conditions mentioned earlier. j) The connecting wires used inside the luminaries, shall be low smoke halogen free, fire retardant e-beam cable and fuse protection shall be provided in input side.

k) Design of the thermal management shall be done in such a way that it shall not affect the properties of the diffuser.

l) The equipment should be compliant to IEC 60598-1, IEC 62031 and IEC/PAS 62612 depending on the type of luminary. m) The LED Module(s), Driver gear, etc. shall be designed in such a way so that temperature of heat sink shall not exceed 70° C. n) All the material used in the luminaries shall be halogen free and fire retardant confirming to standard. o) The infrastructure for Quality Assurance facilities to verify/ test/ prove above specifications must be available at the manufacturing facility. The compliance shall be indicated clearly in the tender itself.

p) All fasteners must be of stainless steel.

q) All glands inside/ outside luminaries must be metallic

r) Heat sink must be thermally connected to MCPCB/ LED light source.

High power and high lumen efficient LEDs suitable for following features shall be used:

a) The working life of the lamp at junction temperature of 85° C (max) at operating current shall be more than 50,000 working hours of accumulative operation and shall be suitable for continuous operation of 24 hours per day. These features shall be supported with datasheet.

b) Adequate heat sink with proper thermal management shall be provided.

c) Lumen maintenance report as per LM 80 guidelines shall be produced for the power LEDs used.

d) Thermal management shall be in such a way that LED soldering point temperature shall not go beyond 75° C.

e) The LED luminaries shall be free of glare.

LED DRIVER specification:

a) Current waveform should meet relevant nation and international standard.

- b) LED Driver shall withstand, withstand voltage up to level mentioned elsewhere in tender and restore once normal working when normal voltage is applied.
- c) The life of the driver should more than 25000 Hrs.
- d) Maximum Temperature rise  $\leq 30^{\circ}\text{C}$  @  $45^{\circ}\text{C}$  Tamb. With safety margin of  $10^{\circ}\text{C}$ .
- e) The control gear should be compliant to IEC 61347-2-13, IEC 62031 and IEC 62384 as per the requirements.
- f) The driver of the luminaries should have Short Circuit, Over Voltage, over current, over temperature, Under Voltage, String Open protections.

The electronic components used shall be as follows:- a) The protective cum adhesive coating used on PCBs should be cleared and transparent and should not affect colour code of electronic components or the product code of the company. b) The construction of PCBs and the assembly for components for PCBs should be as per IS standards.

Illumination Level:

The luminaries shall be so designed that the illumination level shall be evenly distributed and shall be free from glare. The lux distribution curve/ graph/ spatial distribution shall be submitted.

#### GENERAL DATA SHEET

Parameter Value & Detail

- Rated Supply Voltage 230 V ~, 50 Hz
- Input supply voltage range 120-270 V
- Expected Input Frequency 50 Hz +/- 3%
- Working Temperature  $+5^{\circ}$  to  $+50^{\circ}\text{C}$
- Working Humidity 10% - 90% RH
- Usage hours Dusk to dawn
- Power Factor  $\geq 0.90$
- Index of Protection Level IP 66 as per IEC 60529.
- Surge Protection 4 KV
- LED Chip efficacy  $\geq 120\text{ lm/W}$
- Driver Efficiency  $> 85\%$
- Junction Temperature of LED  $< 85^{\circ}\text{C}$
- Rated Life @ L70 50,000 burning hours at  $35^{\circ}\text{C}$  ambient
- Nominal Correlated Colour Temperature  $5000^{\circ}\text{K}$  to  $6000^{\circ}\text{K}$
- Dispersion Angle Minimum  $120^{\circ}$
- Tilting angle Adjustable
- Maintenance factor of 0.85
- Colour Rendering Index  $\geq 75$
- Total Harmonic Distortion  $< 10\%$  (EMI/ EMC Certification)
- LED MAKE Cree/ Osram/ Nichia/ Philips Lumileds

Particulars and Details to be submitted by the bidder:

In order to properly assess and due diligence on submissions, the Bidder should provide following information on the quality and photometric of proposed luminaries.

#### 1. General Description

Following details of the proposed luminary shall be submitted

#### 2. Electrical specifications

Electrical ratings of the proposed luminary product shall be submitted

#### 3. LED chip and driver information

LED chip and driver information of the proposed luminary product shall be submitted

#### 4. Photometric information to be submitted TESTS & CERTIFICATES:

Tests are classified as:-

#### Type test Acceptance test

Routine test.

The luminaries' should be tested as per IEC 60598-2-3: 2002 standards and following test reports should be submitted: -

- (i) Heat Resistance Test
- (ii) Thermal In SITU Test
- (iii) Ingress Protection Test
- (iv) Drop Test
- (v) Electrical/ Insulation Resistance Test,
- (vi) Endurance Test,
- (vii) Humidity Test,
- (viii) Electrical and Photometric Measurements Test Report (IES LM 79)
- (ix) LED Lumen Maintenance Test Report (IES LM 80)
- (x) Vibration test as per ANSI

Type Test: -

Type test certificates for both the luminaries' shall be provided with the technical-bid.

Acceptance Tests: -

These tests are carried out by an inspecting authority at the supplier's premises on sample taken from a lot for the purpose of acceptance of a lot. Acceptance tests shall not be carried out from particular size from the lot on which type tests have already been conducted. Recommended sampling plan is given below.

Sample size and criteria for conformity

The luminaries shall be selected from the lot at random. In order to ensure randomness of selection, procedures given in IS 4905-1968 (Reaffirmed 2001) may be followed.

Routine Tests:

These tests shall be performed by the manufacturer on each complete unit of the same type and the results shall be submitted to the inspecting agency, prior to offering the lot for acceptance test. The firm shall maintain the records with traceability.

Test Scheme & Quality Assurance

Method of Testing: -

Visual and Dimensional Check:

The unit shall be checked visually for all dimensions as per approved design and drawing.

General workmanship should be good; all the components properly secured and sharp edges shall be rounded off. Check the marking and quality of the workmanship visually. Check the rating and make of electronic/ electrical items.

Checking of documents of purchase of LED

Check Document of purchase of LED lamps of approved sources viz. NICHIA/ OSRAM/ PHILIPS LUMILEDS/ CREE.

Resistance to humidity test

This is carried out by suspending the painted panels in corrosion chamber maintained at 100% RH and temperature cycle of 42 to 48° C for 7 days and examining it for any sign of deterioration and corrosion of metal surface.

Insulation resistance test

The insulation resistance of the unit between earth and current carrying parts shorted together shall not be less than 2 MΩ when measured with 500 V megger.

HV test

Immediately after insulation resistance test, an AC voltage of 1.72 KV rms (1500 + 2 x rated voltage) of sine wave form of 50 Hz shall be applied for one minute between the live parts and frame. There shall not be any kind of break down, flashover or tripping of supply.

**Over voltage protection**

The LED Driver Shall be cut off once voltage exceeds 288 V AC. It shall be reconnected when supply comes within limit.

**Surge protection**

It shall withstand a surge of 4 KV at the input terminals for all types.

**Reverse polarity**

The Luminaries' shall withstand polarity reversal. It shall be operated with reverse voltage for Min. 1 minute at maximum value of voltage range. At the end of this period, the supply shall be made correct polarity and Luminary shall operate in a normal way.

**Temperature rise Test:**

Temperature rise Test shall be conducted at 100 V ~ with full load. The temperature rise shall be recorded by temperature detectors mounted at the specified reference points on the body of semiconductors, capacitors and other components as agreed between purchaser and manufacturer. The maximum-recorded temperature under worst conditions shall be corrected to 55° C and compared with maximum permissible temperature (for power devices at junction). Under loading conditions as specified above, the corrected temperature of the power devices shall have a safety margin of minimum 10° C.

Temperature at junction shall not exceed 100° C when corrected to 55° C. The Luminaries' shall also be subjected for short time rating after continuous loading to

ensure the temperature rise is within the permissible limit. The maximum temperature rise of the electronics devices on the PCBs shall be in limit for industrial grade components suitable for 85° C environment. In case of exceeding limit, use of MIL-grade component shall be considered keeping RDSO informed.

**Ra (Colour Rendering Index) measurement test**

The lumen is the unit of luminous flux, which is equal to the flux emitted in a solid angle of one steradian by a uniform point source of one candela.

The initial reading of the chromaticity co-ordinates x & y shall be within 5 SDCM (Standards Deviation for Colour matching) from the standardised rated value as per Annex: D of IEC 60081- 1997.

The initial reading of the general colour-rendering index (Ra) shall not be less than the rated value decreased by 3.

The lumen maintenance of the lamp shall not be less than 80% of the initial lumen after 20,000 burning hours and 70% of the initial lumen after 50,000 hours. The initial lumen will be taken after 100 hours aging. Photometric test shall be conducted as per Annexure: B of IEC 60081-97.

The lumen maintenance test shall be done as per Annexure: C of IEC 60081-97.

**Fire retardant Test**

Fire Retardant test shall be conducted as per IEC 60332-1 of the wire used in the luminaries.

**Test for IP 65 protection**

This test shall be conducted as per IEC 60529.

**Environmental tests (Proto type Test)**

The Luminary shall meet the following tests as prescribed in IEC-60571.

(i) Dry heat test.

(ii) Damp heat test

(iii) Test in corrosive atmosphere

(iv) Combined dust, humidity and heat test

**Reliability Test**

The reliability can only be determined in actual service. However, the following tests shall be carried out on the prototype to simulate as close as possible, the service conditions.

There shall be no failure during this test.

(i) The light unit shall be mounted in an oven maintained at 45° C.

(ii) The light will be operated at the specified maximum voltage and at 45° C for a period of 100 hours.

Photometry Test: -

The test shall be carried out for Total Luminous Flux, Luminous Intensity Distribution, Electrical Power, Luminous Efficacy (calculation), Color Characteristics– Chromaticity, CCT & CRI etc. as per IES LM 79.

Life Test

The lumen maintenance & life test shall be done as per IES LM 80 for LEDs.

Endurance Test

The Luminaire shall be kept “ON” with input voltage of 250 V ~ for 200 hours. After this the Luminaire is subjected to 20,000 cycles of “ON” and “OFF”, each cycle consisting of 3 seconds “ON” and 10 seconds “OFF” period. Luminaire should survive this test. Test is to be continued for 20,000 cycles, followed by performance test.

Safety:

The Luminaire shall comply with the safety requirements as per IEC 61195.

All Tests defined for acceptance other than LM 79 and LM 80 are allowed to carry out at Manufacturer works.

#### 4. INFRINGEMENT OF PATENT RIGHTS

Client shall not be responsible for infringement of patent rights arising due to similarity in design, manufacturing process, use of the components, used in design, development and manufacturing of these light luminaires and any other factor which may cause such dispute. The responsibility to settle any issue rises with the manufacturer.

#### 5. MARKING:

The following information shall be distinctly and indelibly marked on the housing:

Year of manufacture/ Batch Number/ Serial Number

Name of Manufacturer (Engraving only, stickers not allowed)

Rated watt and voltage

Input frequency

#### 6. METHOD OF MEASUREMENT

Supply of the fixture including transport to site, loading and unloading etc. as specified will be treated as one unit for measurement and payment.

#### 7. TRANSPORT, DELIVERY AND STORAGE

The prices shall be F.O.R. site basis including packing & forwarding charges. The quoted price must include all the costs for necessary mode of transportation up to the final location of fixture or site store. The fixture should be supplied with required storage arrangements suitable for placing in open storage yard. All incidental expenses during transportation shall be part of quoted prices including transit insurance. The charges for loading and unloading of equipment at site should form part of offer.

#### 8. GUARANTEE AND WARRENTY

The Bidder shall stand guarantee for the performance of entire fixtures and components for twenty four (24) months from the date of commissioning or from issuance date of completion certificate, whichever is earlier, as agreed up on and as reproduced in the purchase order within the tolerance specified or as permitted by the relevant standards for the equipment in his scope of supply. The Purchaser also reserves the right to use the rejected equipment or part thereof until the new equipment meeting the guaranteed performance is supplied by the Bidder.

#### 9. SPARES

The bidder shall quote for minimum spares required for two years safe operation of light fixtures along with the offer separately.

#### **Item No. 149, 150**

**Supplying and erecting Flexible PVC insulated multi strand multi core 1.1 kv grade ISI marked copper wires of following size to be erected as directed.**

**1.50 Sq.mm 3 core round PVC sheathed**

**4.00Sq.mm 4 core round PVC sheathed**

This specification is for general requirement of the installation, testing and commissioning of Electrical wiring.

**Specification:**

This Specification is drawn out for supply, installation, connection, testing and commissioning of point wiring for light points, ceiling fan points, exhaust fan points, bell points, 5A / 15 A socket outlet points, power socket outlet points, etc. This specification also includes fixing of light fixtures, ceiling fan, wall fan, exhaust fan, bell etc.

**Standards:**

The following Indian Standards, other relevant applicable Indian and International standards and Indian Electricity Rules and Regulations, Indian Electricity Act, relevant specifications, drawings and instructions issued by architect / Consultant office regarding the work, shall be followed by the tenderer.

IS	732	Code of practice for Electrical Wiring Installation (System Voltage not exceeding 650 V)
IS	1646	Code of practice for Fire Safety of Buildings (General) Electrical Installation.
IS	4648	Guide for Electrical Layout in Residential Building
IS	694	PVC Insulated Cables
IS	8130	Specifications of Conduits for Electrical Installation
IS	2509	Rigid Non-Metallic Conduits for Electrical Wiring
IS	6946	Flexible (Pliable) Non-Metallic Conduits for Electrical Installation.
IS	9537	Specification of PVC Conduits
IS	3415	Fittings for Rigid Non-Metallic Conduits
IS	1653	Rigid Steel Conduits for Electrical Wiring
IS	2667	Fittings for Rigid Steel Conduits for Electrical Wiring
IS	3419	Specification for Fittings of Rigid Non Metallic Conduits
IS	3480	Flexible Steel Conduits for Electrical Wiring
IS	3837	Accessories for Rigid Steel Conduit for Electrical Wiring
IS	1293	3 Pin Plugs and Sockets
IS	3854	Switches for Domestic Purpose

The relevant requirement of following act, rules and regulation shall also be fulfilled by the tenderer.

- Indian Electricity Act 2003 (as amended up to date)
- Indian Electricity Rules 1956 (as amended up to date)
- Regulations laid down by the Chief Electrical Inspector of the State
- Regulations laid down by the DGVCL
- Regulations of FIA of India
- Regulations laid down by the Factory Inspector of the State
- Any other regulations laid down by the local authorities

Installation of any equipment shall be done according to the guide line provided in the Installation & operation manuals of equipment manufacturers. All the Work shall be done with latest best practices in the industry.

**Point Wiring:**

The Point wiring shall includes the scope of work of Supply, installation, fixing of conduits with necessary accessories, junction / pull / inspection / switch boxes and outlet boxes, Supplying and drawing of wires (of required size) including earth continuity wire, Supply, installation and connection of flush type switches, sockets, cover plates, switch plates, and fixing fan regulators, ceiling roses, button / swan holder, connector etc., for the branch wiring from the distribution board, testing and commissioning of point wiring (as describe else where in this specification) as required.

The point wiring shall includes, earth continuity conductor / wire (min. 14 SWG) from the distribution board to the earth pin / stud of the outlet / switch box and to the outlet points. Unless otherwise specified on the drawings, the point wiring shall be done as follows:

**Material**

**PVC Conduits**

All non-metallic PVC conduits shall conform to IS: 9537. the conduit shall be plan and type as specified in IS: 9537 and shall be used with the corresponding accessories (Refer IS: 3419 specification for fittings for rigid non metallic conduits).PVC conduits shall be rigid un-plasticised, heavy gauge having 2.0 mm. wall thickness up to 20 mm. diameter conduit and 2.5 mm. wall thickness for all sizes above 20 mm. diameter.

**M.S. Conduits**

MS Conduits shall conform to IS: 1653, finished with galvanized surface. No steel conduits less than 25 mm. in diameter shall be used. Conduits shall be solid drawn of lap-welded type, with minimum wall thickness for conduits having 25mm. and above diameter.

The conduits accessories such bends, coupling etc. shall be conforming to the relevant Indian Standard specification.

The conduits shall be delivered in original bundles to the site of construction. Each length of conduits shall bear the label of manufacturers.

Rigid non-metallic, PVC conduit shall be used for all purpose while steel conduits shall be used for surface installation. Conduits shall be concealed in walls and slabs or exposed (surface mounted) as per the site requirement or specified by architect/consultant.

**Boxes**

All the boxes for switches, sockets and other receptacles, junction boxes, pull boxes and outlet boxes shall be fabricated from 2.0mm. thick mild sheet paint with two coats of red-oxide and then two coats of enamel paints as called for. Colour of the paint shall be as approved by the client. The boxes shall have smooth external finished surface. Boxes in contact with earth or exposed to the weather shall be of 2mm. mild steel and hot dip galvanized after fabrication. Separate screwed earth terminal shall be provided in the box for earthing purpose. All boxes shall have adequate no. of knock out holes of required diameter for conduits entry. Switch boxes to receive switches, socket outlets, power outlets, telephone outlets, fan regulators,

etc. shall be fabricated to the approved shape and size to accommodate with adequately sized rod/hook to fix ceiling fan. The boxes shall be of minimum depth of 65mm.

Boxes installed for concealed wiring shall be provided with suitable extension rings or plaster covers as required. Boxes for use in masonry block or tiled walls shall be square cornered tile type, or standard boxes having square cornered tile type covers. These boxes shall be installed in the center of the masonry block or tiles.

Cast metal boxes installed in wet locations and boxes installed flush with the outside of exterior surface shall be gasketed.

**Cover Plate**

The cover of the boxes to receive outlet points shall be of best-anodized sheet cut to shape and size or plate of approved manufacturers.

**Switches**

Switches shall conform to IS: 3854, IS: 4615. The switches shall be single pole, single or two way and shown on the drawings or as specified. They shall be of moulded type rated for 250 volt, and of full 6 / 15 A capacities. They shall be provided with insulated dollies and covers.

The switches shall be rocker operated with a quite operating mechanism with bounce free snap action mechanism enclosed in an arc resistant chamber. The switches shall have pure silver and silver cadmium contacts. The switches shall be flush modular type. The make of the switches shall be as indicated in the drawings or BOQ or make of material or as suggested and approved by the architect/consultant. The switches installed in outdoor area shall be industrial, metal clad type, and shall be provided in weather proof enclosures, complete with weather proof gasketed covers.

**Sockets**

The sockets shall conform to IS: 1293. each socket shall be provided with control switch of appropriate rating. The sockets shall be moulded type, rated for volts, and either of full 5 A or 15 A capacity, as mentioned on the drawings.

Sockets shall be of three pin type; the third in being connected to earth continuity conductor. the socket shall be flush modular type. The sockets installed in machine room, plant room or wet / damp area shall be metal clad weather proof type. The finishing and make of all the sockets shall be same as light switch. The socket shall have fully spring contacts and solid brass shrouded terminals to ensure positive electrical connections.

The sockets shall be provided with automatic shutters, which open only when earth pit of the plug inserts in the socket. The socket shall be provided with three pin plug top suitable to the socket and of the same make as socket.

**Wire & Cables**

The wiring shall be done with single core, FRLS / ZHFR insulated, 650/1100 volt grade, copper conductor wires / cables lay through PVC / Steel conduits as directed. The cables shall conform to IS: 694. The plain annealed copper conductors shall comply with IS: 1554. The FRLS compound shall comply with the requirements of IS: 694. It shall be applied by an extrusion process and shall form a compact homogenous body. Manufacturers name shall be provided throughout the length of cable.

**Following color of wire shall be used for the identification of power circuit.**

Single phase	Red
Three phase	Red, Yellow, Blue
Neutral	Black
Earth	Green

Unless otherwise specified in the drawings the following size of the wire/cables shall be used for internal wiring.

**For the wiring for lights, exhaust fans, ceiling fans, bell, convenience socket outlet points etc.**



From D.B. to switch boards	2.5 mm <sup>2</sup>
From switch boards to Fan / Exhaust Fan points, convenience socket outlet points.	1.0 mm <sup>2</sup>
From switch boards to Light points	1.0 mm <sup>2</sup>
Earth wire switch board to Out let point	0.75/1.0 mm <sup>2</sup>

**For the wiring of power socket outlet having not more than two 15 A power outlets**

From D.B. to first power outlet	4.0 mm <sup>2</sup>
From first power outlet to second power outlet	2.5 mm <sup>2</sup>
power socket outlet circuit having single 15 A power outlet (like water heater)	4.0 mm <sup>2</sup>
Earth wire	14 SWG or 3.0 mm <sup>2</sup>

Separate circuit shall run for each water heater, kitchen equipment, window air conditioner, and similar outlets at location as shown on drawings.

The earth continuity conductor shall be similar to circuit cables and shall be drawn through conduit along with other circuit cables. The size of the earth continuity conductor shall be as follows.

Normal cross-section area of largest associated copper circuit conductor Normal cross-sectional area of earth continuity conductor.

Normal cross-section area of largest associated copper circuit conductor	Normal cross-sectional area of earth continuity conductor.
mm <sup>2</sup>	mm <sup>2</sup>
1.5	1.5
2.5	1.5
4.0	2.5
6.0	2.5
10	6.0
16	6.0
25	16
35	16
50	16

**Installation:**

**Concealed / Surface Conduit Works:**

Prior to laying of conduits, the contractor shall submit for approval, the shop drawing for conduit layout indicating the route of the conduits, number and size of the conduits, location of junction / inspection / pull / outlet boxes, size and location of switch boxes, number and sizes of wires pulled through each conduits and all other necessary relevant details. Only after the drawings are approved, the contractor shall precede the work of laying of conduits.

**Laying Of Conduits:**

Conduits shall be laid before casting in the upper portion of a slab / in PCC if below flooring or otherwise, as may be instructed in accordance with approved drawings, so as to conceal the entire run of conduits and

ceiling outlet boxes. Conduits shall be so laid that they are interconnected. This is required to facilitate pulling of wires from different openings in case of any of the outlet is outlets so blocked during slab casting. Vertical drops shall be cut by the contractor to sufficient depth to allow full thickness of plaster over conduits. The width of the chases will be made to accommodate the required number of conduits. The chases will be filled with cement, coarse.

When the conduits are to be embedded in a concrete member it shall be adequately tied to the reinforcement to prevent displacement during casting. Tie wire to be supplied by the contractor.

Cutting of chases in any RCC member / finished floor / already finished surface is not allowed unless prior approval of Site Engineer is taken in site instruction book. If a chase is cut in an already finished surface, the contractor shall fill the chases and finish it to match the exiting finish including painting at his cost to Site Engineer's satisfaction.

Contractor shall not cut any iron bars to fix the conduits. Puncher of wooden / steel shutting for RCC slab / beams / column etc. for conduit work is also not allowed, unless Site Engineer permits in site instruction book under special conditions.

Run of conduit pipe through expansion joints in RCC members should be avoided as far as possible and if unavoidable, flexible conduit pipe should be used with ceiling outlet box on both sides of expansion joints. Conduits on surface of RCC walls /RCC members shall be avoided as far as possible and if unavoidable prior approval of Site Engineer on sample saddles, clamps screws and a minimum 5 mtr. conduit laid on surface shall be taken, to achieve best possible workmanship. Distance between 2 consecutive clamps for fixing conduit on surface shall not exceed 900 mm. wooden patties for fixing saddles / clamps shall be used. Use of roll plug / steel fastener with hard setting / sealing compound is recommended.

In case of stone masonry, necessary conduits with M.S. boxes should be placed as the masonry is in progress, since after completing masonry; it is very difficult to cut chases in wells. Special location of cement concrete shaft is also recommended to conceal conduit in stone masonry and the same shall be provided by Architect / Consultant.

Conduit laying below the flooring should be avoided. Wherever it is unavoidable G.I. pipe should be used with prior approval of Site Engineer.

#### **Concealed Installation With Rigid PVC Conduit:**

The conduits shall be concealed slab, floor, walls, columns etc. All the rigid PVC conduits used for concealed installation shall be as per IS: 9537 and its accessories shall be as per IS: 3459. Whenever necessary bends or diversion may be achieved by bending the conduits with the help of bending spring. No other method of bending is allowed. Conduit pipes shall be joint with the help of plain coupler fixed at the end with the help of vinyl solvent cement. No other method of joining is permissible.

Prior to fixing the conduits, the complete route shall be marked on site for the approval of consultant.

#### **Fixing Of Conduit:**

Conduits embedded in concrete shall be installed in the framework before pouring concrete. The conduits shall be installed above the bottom reinforcing bars, and shall provide positive wore fastening of the conduit to the reinforcing rods at an interval of not more than one meter, but on either side of couplers or bends or outlet /pull / junction boxes or similar fittings, proper hold fast shall be fixed at a distance of 30 cm from the center of such fittings. Conduits embedded in the wall shall be fixed inside the chase. The chase in the wall shall be neatly made and be fixed in the manner desired. In the case of building under construction, chase shall be provided in the wall at the time of their construction and shall be filled up neatly with cement mortar 1:4 for fixing of conduit and brought to the original finish of the wall. Cutting of horizontal chase in walls is prohibited. The conduits shall be fixed inside the chase by means of staples or by means of saddles not more than 60 cm apart.

Conduits shall be so arranged as to facilitate easy drawing of wires through them. Entire conduit layout shall be done in such a way as to avoid additional junction boxes other than light points. The wiring shall be done in a looping manner. All the looping shall be done in either switch boxes or outlet boxes. Looping in

junction or pull boxes are strictly not allowed. Where conduits cross building expansion joints, adequate expansion fittings or other approved devices shall be used to take care of any relative movement.

Conduits shall be installed in such a way that the junction, derivation and pull boxes shall always be accessible for repairs and maintenance work. The location of junction / pull boxes shall be marked on the shop drawings and approved by the architect / Consultant.

A minimum distance of 200 mm shall be maintained between electrical conduits and hot water lines, communication/data cables such as telephone, LAN, TV, etc. in the building. Where ever required to cross the communication / data cable, it shall be crossed as possible as towards perpendicular to each other.

No run of conduit shall exceed ten meter. between adjacent draw in points nor shall it contain more than two right angle bends, or other derivation from the straight line.

Caution shall be exercised in using the PVC conduits in location where ambient temperature is 50 dg cel. or above. Use of PVC conduits in places where ambient temperature is more than 60 dg cel. is prohibited. The entire conduits system including boxes shall be thoroughly cleaned after completion of installations and before drawing of wires. Conduits system shall be erected straight as far as possible. Traps where water may accumulate from condensation are to be avoided and if unavoidable, suitable provision for drawing the water shall be made.

All joining method shall be subject to the approval of the client.

Separate conduits shall be provided for the following system.

- 15 A power outlets.
- 5 A outlets and lighting system.
- Low voltage system.
- Telephone / intercom system.
- C.C.T.V. system.
- Sound system.
- Computer date cabling system.
- Equipment wiring.

**Conduit Joints:**

Conduits shall be joined by means of plain couplers vinyl and / or solvent cement. Where there are long runs of straight conduits, inspection type couplers shall be provided at intervals, as approved by the client. The conduits shall be thoroughly cleaned before making the joints. In case of plain coupler joints, proper jointing material like a vinyl solvent cement (gray in color) or any material as recommended by the manufacturer shall be used.

**Bends In Conduit:**

Whenever necessary, bends or diversions may be achieved by bending the conduits or by employing normal bends. No bends shall have radius less than 2.5 times outside dia. of the conduits. Heat may be used to soften the PVC conduit for bending, but while applying heat to conduit, the conduit shall be filled with sand to avoid any damage to the conduit.

**Outlets:**

All the outlets or fittings, switches etc. shall be boxes of substantial construction. In order to minimize condensation or sweating inside the conduits, all outlets of conduit system shall be properly drained and ventilated, but in such a manner as to prevent the entry of insects, etc. Fixing between conduit and boxes, outlet boxes, switch boxes and the like must be provided with entry spouts and smooth PVC bushes. Joints between conduits and any type of boxes shall be affected by means of conduit couplers in to each of which shall be coupled smooth PVC bush from inside the box. In any case all the joints shall be fully watertight.

**Bunching Of Cables:**

Cables of AC supply of different phase shall be bunched in separate conduits. The number of insulated wires/ cables that may be drawn into the conduits shall be as per the following table. In this table, the space factor does not exceed 40%. However, in any case conduits having lesser than 19 mm dia. shall not be used. Maximum permissible number of 650/1100 volt grade single core wire/cables that may be drawn in rigid PVC conduits.

Cable Size	Size of Conduits in mm				
	19/20	25	32	38/40	50/51
mm <sup>2</sup>					
1.5	4	8	15	-	-
2.5	4	6	10	-	-
4.0	2	4	8	12	-
6.0	1	4	6	10	-
10	1	3	5	8	-
16	-	2	4	5	12

Wires carrying current shall be so bunched in the conduit that the outgoing and return wires are drawn in the same conduit. Wires originating from two different phases shall not be run in the same conduit.

#### **Installation With Rigid Steel Conduits:**

All conduits and its accessories shall be of threaded type and under no circumstances pin grip type or clamp type accessories be used.

##### **Fixing Of Conduits**

Conduit pipes shall be fixed with heavy gauge spacer bar saddles. The saddles shall be of 3 mm x 19 mm galvanized mild steel flat, properly treated and securely fixed to support by means of nuts and bolts raw bolts, brass machine screws, as mentioned, at an interval of not more than one meter but on either side of couplers, or bends, or junction / pull / outlet boxes or similar fittings, saddles shall be fixed at a distance of 30 cm from the center of such fittings. Draw boxes shall be located at convenient location for easy drawing of wires.

Every mains and sub mains shall run in an independent conduit with an independent earth wire of specified capacity along the entire length of conduit.

The conduits to be installed shall be of ample cross section area to facilitate the drawing of wires. The diameter of the conduit shall be selected as per table specified in this specification. But in no case it shall be less than 25 mm diameter.

Entire conduit layout shall be done such as to avoid additional junctions boxes other than for outlet points. Conduits shall be free from sharp edge and burrs. Conduits shall be laid in a neat and organized manner as directed and approved by the client. Conduit runs shall be planned so as not to conflict with any other services pipe, lines /duct.

The entire conduit system shall be electrically and mechanically continuous and shall be bonded together by means of approved type earthing clamp and earthed through a bare copper conductor of 14 SWG to the earthing terminals on the nearest distribution board.

If required, connection between PVC and steel conduits shall be through a junction box. Direct connection between PVC and steel conduits are not allowed.

Where exposed conduits are suspended from the structure, they shall be clamped firmly and rigidly to hangers of design to be approved by client. Where hangers are to be anchored to reinforce at the time of concrete, appropriate insets and necessary devices for their fixing shall be left in position at the time of

concreting, making holes and opening in the concrete will generally not be allowed. In case, it is unavoidable, prior permission of the client shall be obtained.

**Conduit Joints:**

Conduits pipes shall be joined by means of screwed couplers and screwed accessories, as per IS: 2667. The threads shall be free from grease or oil. In long distanced straight runs of conduit, inspection type couplers two way junction boxes at reasonable intervals shall be provided or running threads with couplers and lock nuts shall be provided. The bare threaded portion shall be treated with anti-corrosive paints. Threads on conduit pipes in all cases shall be between 11mm to 27mm long, sufficient to accommodate pipes to full threaded portion of couplers or accessories. Cut ends of conduit pipes shall have no sharp edges or any burrs left, to avoid damage to the insulation of conductors while pulping them through such pipes.

Brass female bushes shall be used in each conduit termination in a switch box, outlet box, electrical panel or any other box. Conduit shall be secured in each outlet box switch box, electrical panel or any other box by means of one brass hexagonal lock nut and bush, outside and inside the box.

At each building, expansion joints approved oil tight double wire wound flexible steel conduit or any other approved method shall be used. This shall be united on both sides with the rigid conduits by suitable union. Conduits installed in the plant room for mechanical equipment shall be properly clamped with the mechanical supports, but in no case, it shall be fixed with the body of the equipment. The connection of conduit to the mechanical equipment shall be through oil tight double wire wound flexible steel conduit. In any case the length of the flexible conduit shall not exceed one meter. The flexible conduit shall be properly clamped with any cover or any removable part of the equipment.

**Bends And Conduits:**

All necessary bends in the system including diversion shall be done by bending pipes or by inserting suitable solid or circular inspection type normal box or similar fittings. Conduit fittings shall be avoided as far as possible on conduit system exposed to weather, where necessary, solid type fittings shall be used. Radius of such bends in conduit pipes shall be not less than 75mm. No length of conduit shall have more than the equivalent of four quarter bends from outlet, the bends at the outlets not bending counted.

**Protection Against Dampness:**

In order to minimize condensation or sweating inside the conduits, all outlets of conduit system shall be properly drained and ventilated, but in such a manner as to prevent the entry of insects, as far as possible.

**Protection Of Conduit Against Rust:**

The outlet surface of the conduits including bends, junction boxes, etc., forming part of the conduit system shall be adequately protected against rust, particularly when such system is exposed to weather. In all cases, no bare / threaded portion of conduit pipe shall be allowed unless such bare threaded portion is treated with anti-corrosive coating or covered with approved plastic compound.

**Bunching Of Cables:**

Unless otherwise specified, insulated conductors of different phases shall be bunched in separate conduit. Wires carrying current shall be so bunched in the conduit that the out going and return wires are drawn into the same conduit. Wires originating from two different phases shall not be run in the same conduit. The number of insulated wires / cables that be drawn into the conduits shall be as per the following table. Maximum permissible number of 650/1100 volt grade single core wire/cables that may be drawn in rigid Steel conduits.

Cable Size	Size of Conduits in mm				
	20	25	32	38	51
mm <sup>2</sup>					
1.5	5	10	14	-	-
2.5	5	8	12	-	-

4.0	3	6	10	-	-
6.0	2	5	8	-	-
10	-	4	7	6	-
16	-	3	5	6	-
25	-	-	3	4	6
35	-	-	2	3	5
50	-	-	-	-	4

### Installation Of Ceiling / Wall Outlet Boxes For Lights / Fans

Outlet boxes shall be protected at the time of laying by filling with jute / earth / cotton etc. so that no cement mortar finds its way inside during concreting or plastering etc. typical sketches for such outlet boxes shall be supplied along with other working drawings. In beams conduit socket shall be provided in place of outlet boxes. The same shall be used for installation of light/fan etc.

For fixing light fixtures / brackets, outlet boxes complete with check nut for holding conduits shall be used. For lighting fixture suitable for 20 watts fluorescent tubes / incandescent lamps / mercury vapor lamps, only one outlet box is required. For fixing lighting suitable for 40 watts fluorescent lamps, two numbers outlet boxes should be provided at a distance of 300 mm. away from the centre in the longitudinal direction of the fixture, so that the use of patties / roll plug etc. may be avoided, as well as wiring from outlet box to the light fitting so to be installed in RCC beam and due to heavy reinforcement at the bottom of it is not possible to provide outlet boxes simple conduit should be provided. However alternative-fixing arrangement shall be made in consultation with Architect / Consultant.

For fixing ceiling fans, circular/square outlet boxes, 100 mm. size, complete with 12 mm. dia. Mild Steel rod 300 mm. long, for holding 12 mm. dia. Mild Steel cover 125 mm. dia. at bottom shall be used.

### Installation Of Draw Out Junction Boxes

Steel draw out boxes shall be provided at a convenient points on walls/ceilings to facilitate pulling of long runs of cables / wires. These shall be completely concealed with Anodized Aluminum, flush with plastic works. The location of these boxes is to be decided prior to fixing, as per site requirement and following should be treated as general guidance for deciding the location of these:

- These should be provided at a place where these are not in direct view. Recommended place is 400/450 mm. below ceiling, if conduits are running vertically.
- Junction box in the offset of bottom of RCC beam and vertical wall should not be provided.
- If junction boxes are coming side by side for two or more conduits, one common M.S. box of proper size can be used to act as junction box.
- If junction box is to be provided in ceiling, its possible should be so located that it is in line with other light / fan points.
- Junction boxes should never be used for splitting one conduit into two or more. Junction box for such functions is avoidable and for this, number of conduits to be connected to one switch board should be calculated correctly as per drawing before laying conduits in ceiling.
- Locating junction boxes on outer surface of exterior walls of building should be avoided as these are in direct view and are also exposed to weather.
- Junction boxes should never be closed permanently by plaster. Removable covering of aluminium should be provided for conduit junction boxes for M.S. junction boxes removable hylam plate should be provided. This cover may be painted with wall colour.

- Junction boxes in important rears should be avoided and can be located in toilets / corridors / service shafts and stores etc.

**Installation of Switch Boxes**

Switch Boxes shall be installed at 1350 mm above finished floor level unless otherwise indicated on the drawings.

Steel boxes of required sizes, shall be provided to house speed regulators of fans, switches for lights, fans, plug sockets etc. as per requirement of drawings. These should be so designed that accessories on Anodized aluminum sheet could be mounted with tapped holes and brass machine screws, leaving ample space at the back and on the sides for accommodating wires and check nuts at conduits entries. These shall be attached to conduits by means of check nuts on all walls of the boxes through which the conduits are entering. These shall be completely connected leaving edges flush with finished wall surfaces. Anodized aluminum cover should be fixed to these switch boxes by means of brass chrome plated machine screws and cup washers. Utmost care shall be taken by contractor to ensure that all switch boxes are in line and level. Inside each switch box, bolt shall be welded to receive earthing wire.

**Installation Of Switch And Socket**

The switch controlling the light point or fan shall be connect on the phase wire of the circuit and neutral shall be continuous, having no Fuse/MCB/RCCB or switch installed in the line except at the D.B. All fan regulators shall be fixed inside the switch boxes on adjustable flat M.S. strips / plates with tapped holes and brass machine screws, leaving ample space at the back and side for accommodating wires.

The cover plates to the switch box shall be fixed by means of sunk head brass cadmium screws. Where two or more switches and fan regulators are installed together, they shall be provided with one gang cover plate with knockouts to accommodate required number of switches, sockets and regulators.

The witch controlling the socket outlet shall be on the phase wire of the circuit. The third pin of the socket shall be connected to the earth continuity conductor of the circuit.

The switch boxes, installed back-to-back in the same wall shall be offset from each other, 150 mm horizontally, to preclude noise transmission.

**Cleaning And Protection Of Conduit System**

The entire conduit system including outlet boxes, junction boxes and switch boxes shall be thoroughly cleaned after completion of erection and tested for not blockage by air / sound or steel wire prior to finishing of building by air / sound or steel wire prior to finishing of building and before drawing in of cables / wires to safeguard conduit system against filling up with the plaster / cement slurry / water etc. all the outlet and switch boxes will have to be provided with temporary jute / cotton filling, covers and plugs etc. Within tendered cost which shall be replaced later on by hylem / sheet cover after wiring as required.

**Drawing Of Conductors**

The drawing and joining of copper conductor or wires shall be executed with due regard to the following precautions, while drawing insulated wires into the conduits, care shall be taken to avoid scratches and kinks which may cause breakage of conductors. There shall be no sharp bends.

Insulation shall be shaved off for a length of 15 mm at the end of wire like sharpening of a pencil and it shall not be removed by cutting it square or ringing.

FRLS insulated copper conductor wire ends before connection shall be properly soldered (at least 15 mm length) with soldering flux / copper solder, for copper conductor. Strands of wires shall not be cut for connecting to the terminals. All strands of wires shall be soldered at the terminals. All strands of wires shall be soldered at the end before connection. The brass-screws shall have flat ends. All looped joints shall be soldered and connected through terminals block / connectors. The pressure applied to tighten terminal screws shall be just adequate, neither too much nor too less. Conductors having nominal cross section are exceeding 4 sq. mm. shall always be provided with crimping type cable sockets. At all bolted terminals, brass flat washer of large area and approved steel spring washers shall be used. Brass nuts and bolts shall be used for all connections.

Only certified wireman and cable joiners shall be employed to do joining work.

For all internal wiring FRLS insulated wires of 650 / 1100 volts grade shall be used. The sub-circuit wiring for point shall be carried out in looping system and no joint shall be allowed in the length of the conductors. No wire shall be drawn in to any conduit, until all work of any nature that may cause injury to wire is completed. Care shall be taken in pulling the wires so that no damage occurs to the insulation of the wire. Before the wires are drawn into the conduits the conduits shall be thoroughly cleaned of moisture, dust, and dirt of any other obstruction by forcing compressed air through the conduits.

### **Joints**

The wiring shall be by looping back system, and hence all joints shall be made at main switches, distribution boards, socket outlets, lighting outlets and switch boxes only. No joints shall be made inside conduit and junction boxes. Contractors shall be continuous from outlet to outlet. Joints where unavoidable, due to any specified reason, prior permission in wiring shall be obtained from the client before making such connections. Joints by twisting conductors are prohibited.

### **Load Balancing**

Balancing of circuit in three phase installation shall be planned before the commencement of wiring and shall be strictly adhered to.

### **Earthing**

All earthing systems shall be in accordance with IS: 3043 - 1985 code of practice for earthing. A separate Earthing System specification shall be provided ( Pl. ref. Doc ID : Ar0601 SE057).

### **Installation Of Lighting Fixtures / Fans**

#### **Installation Of Lighting Fixtures**

This work includes the connections of 2 core 1.0/1.5 mm<sup>2</sup> PVC insulated wires and earth wire from 5 A pvc/Bakelite connector of light point to the connector inside the lighting fixture, connections, fixing of lighting fixture complete with all accessories, lamps on wall / roof / steel truss etc. testing the lighting fixture and commissioning. If wire length of light point is enough to reach connector of light fitting, connector in light point can be deleted.

#### **Installation Of Fan / Exhaust Fans**

This work includes the connections of 2 core 1.5 mm<sup>2</sup> PVC insulated wires and earth wire from 5 A pvc/Bakelite connector of fan / exhaust fan point to connector of fan / exhaust fan, connectors, fixing of fan in hook provided in the box, making exhaust fan opening in walls including repair / finishing of opening and fixing of exhaust fan complete with accessories and louvers on walls with hold-fasts, testing the fan / exhaust fans and commissioning.

#### **Installation Of Bracket For Street Light Fittings**

The brackets shall be made of 38 mm. NB MS class "B" pipe approx. 1.8 mtr. long bent at the center at angle 120°C. with necessary holding brackets, hold fasts etc, with special reducer at the end to accommodate type of streetlight fitting to be fixed. Bracket shall have 1 coat of anti-corrosion paint before dispatch to site and 2 coats of approved make and shade of aluminum paint. This bracket shall also be provided with one M.S./PVC watertight box complete with the connector, neutral link, earth connection, MCB, etc.

#### **Testing Of Installation**

After completion of work and before put into service, the following tests shall be carried out and requirement specified below shall fulfilled.

#### **Insulation Resistance**

The insulation resistance shall be measured by applying 500 volt megger with all fuses in places, circuit breaker and all switches closed.

The insulation resistance shall be measured between Phase to Phase, Phase to Neutral, Phase to Earth, and Neutral to Earth.



The insulation resistance shall not be less than 50 Mega Ohms divided by the number of points on the circuit.

#### **Earth Continuity Path**

The earth continuity conductors shall be tested for electrical continuity and the electrical resistance of the same along with the earthing lead but excluding any added resistance or earth leakage circuit breaker measured from the connection, with the earth electrode to any point in the earth continuity conductor in the completed installation and shall not exceed one ohm.

#### **Polarity of Single Pole Switches**

A test shall be made to verify that single pole switch is connected to one of the phase of the supply system only.

#### **Completion Certificates**

All the above tests shall be carried out in presence of client and the results shall be recorded in prescribed forms. Any fault during the testing shall be immediately rectified and that section of the installation shall be retested. The completed test result form shall be submitted to the client for approval.

On completion of an electric installation a certificate shall be furnished by the contractor, countersigned by the certified electrical supervisor (a person holding a certificate of competency issued by the (DNH Government) under whose direct supervision the installation was carried out. This certificate shall be in a prescribed form as required by the local electric supply authority.

NOTE : It is to be noted that all the liaising work with power supplying authority shall be carried out by the licensed electrical contractor including the submission of different forms, test reports, any correspondence etc. However any legal fees, estimate cost, registration fees shall be paid by Municipal Council.

#### **Item No. 151**

**Supply, laying, testing & commissioning 1.1 kV grade, XLPE insulated, stranded Aluminium conductor, galvanised steel flat strip / round wire armoured, extruded PVC type ST2 sheathed, heavy duty cable (to be laid on wall surface with necessary clamps / in existing cable trench / cable trays / conduit / pipe sleeves at road crossing or floor as per site requirement) conforming to IS: 7098 (Part-1) & IEC:**

**60502 (Part-1) of following sizes:**

**(d) 4 Core x 10 Sq.m.m**

- Loading, unloading and delivery of cable at site to store
- Internal shifting of cable
- Supply and fixing of cable clamp, bracket, support, cable tray/rack, encasing in GI Pipe, route markers.
- Earthing the glands and armoring with earthing and jumper and also connecting to common earth bar.
- Testing & submission of all cables laid at head works

The diameter/height/size/type will be as shown in BOQ.

#### **Design Conditions:**

All equipment and materials will be selected and rated for use at the following site conditions.

- Summer outdoor temperature: 55°C.
- Ground temperature: 40°C.
- Earth Resistivity: 200 deg.C.cm/w
- Relative Humidity: 95% Max.
- Atmospheric Condition: Non Corrosive, Humid and dusty

#### **Scope:**

This section shall cover supply, laying, testing and commissioning of medium voltage XLPE Cables. This specification gives the general requirement of cables. However, it is the responsibility of the vendor to take the joint measurement and obtain client's approval before the placement of orders to the main supplier /manufacturer. Cut lengths will not be accepted.

**Standards:**

The following standards and rules shall be applicable:

- IS : 7098 Part I XLPE insulated electric cables (heavy duty).
- IS : 3961 Recommended current ratings for cables.
- IS : 8130 Aluminium conductors for insulated cables.
- Indian Electricity Act Rules.

**Measurements:**

The cables will be measured in meters. The unit rate shall include cutting the cable into required lengths, packing, loading, unloading, insurance, transportation, delivery to stores/site as per work order, stocking in stores, testing of cables etc. of medium voltage cable. Total quantity in meters shall be measured lug to lug basis.

Important Note: A joint measurement by Contractor and BMC representative shall be taken after order before starting manufacturing of cable to ensure total length required. Length of each run etc. cable shall be supplied accordingly. Payment shall be made at actual lug to lug.

**Construction:****General:**

The medium voltage cables shall be supplied, laid, connected, tested and commissioned in accordance with the drawings, specification, relevant Indian Standards specifications, manufacturer's instructions. The cables shall be delivered at site in original drums with manufacturer's name, size, and type, clearly written on the drums.

**Material:**

Medium voltage cable shall be XLPE insulated. PVC sheathed, aluminium or copper conductor, armoured conforming to IS : 7098 Part I.

**Type:**

The cables shall be circular, multi core, annealed copper or aluminium conductor, XLPE insulated and PVC sheathed, armoured or un armoured.

**Conductor:**

Uncoated, annealed copper / aluminium, of high conductivity up to 4 mm. Size, the conductor shall be solid and above 4 mm., conductors shall be concentrically stranded as per IEC : 228.

**Insulation:**

XLPE rated 70 c. extruded insulation.

**Core Identification:**

- Two Core: Red & Black
- Three Core: Red, Yellow & Blue
- Four Core: Red, Yellow, Blue & Black
- Single Core: Green, Yellow for earthing
- Black shall always be used for neutral.

**Assembly:**

Two, three or four insulated conductor shall be laid up, filled with non-hygroscopic material and covered with an additional layer of thermoplastic material.

**Armour:**

Galvanized Steel flat strip/round wires applied helically in single layers complete with covering the assembly of cores.

For cable size upto 25 sq. mm: Armour of 1.4 mm dia G. I. round wire

For cable size above 25 sq. mm: Armour of 4 mm wide .8 mm thick G. I. strip

**Sheath :**

XLPE 70 deg. C. rated extruded.

Inner sheath should be extruded type and shall be compatible with the insulation provided for the cables. Outer sheath should be of an extruded type layer of suitable PVC material compatible with the specified ambient temp. 50 deg. C operating temperature of cables. The sheath shall be resistant to water, ultraviolet radiation, fungus, termite and rodent attacks. The color of outer sheath shall be black.

Sequential length marking required at every 1.0 meter interval on outer sheath.

Vendor has to furnish resistance/reactance/capacitance of the cable.

**Rating:**

Up to and including 2200 volts.

## 2. Testing

- **Finished Cable Work At Manufacturer's Works :**

The finished cables shall be tested at manufacturer's works. Following routine test for each and every length of cable and copy of test results shall be furnished for each length of cable along with supply. The cables shall be tested in presence of client's representative.

- **Voltage Test :**

Each core of the cable shall be tested at room temperature at 3 KV A.C. R. M. S. for a duration of 5 minute.

- **Conductor Resistance Test :**

The D.C. resistance of each conductor should be measured at room temperature and the result shall be corrected to 20 deg. C. to check the compliance with the values specified in IS: 8130 –1976.

Cable Test Before And After Laying Of Cables At Site: -

- Insulation resistance test between Phases, Phase to Neutral and Phase to Earth.
- Continuity test for all the phases, neutral and earth continuity conductor.
- Sheathing continuity test.
- Earth resistance test of all the phases and neutral.

All tests should be carried out in accordance with relevant Indian Standard Code of practice and Indian Electricity Rules. The vendor shall provide necessary instruments, equipment's, labour for conducting the above test, and bear all expenses in connection with such tests. All test shall be carried out in the presence of the client and result shall be recorded in the prescribe form.

**Cable Marking:**

Embossing On Outer Sheath:

The outer sheath shall be legibly embossed with following legend :

ELECTRIC CABLE: 2200 Volt, Size: 3.5 C \* \_\_\_\_\_ mm<sup>2</sup>. or 3 C \* \_\_\_\_\_ mm<sup>2</sup>

Manufacturer's name and year of manufacturing.

The letter and figures shall be raised and shall consist of upright block characters. The maximum size of the characters shall be 13 mm. And the minimum size 15 % of the cable circumference or 3 mm whichever be the greater. The gap between the end of one set of embossed characters as above and the beginning of the next shall not exceed 150 mm.

Cable length marking at interval of one meter length shall also be embossed/indicated in figures.

**Sealing, Drumming And Packing:**

After test at the manufacturer's works, both ends of the cable shall be sealed to prevent the ingress of moisture during transportation and storage.

The cable ends shall be suitably sealed against entry of moisture, dust, water etc. with cable compound as per standard practice.

All cable shall be adequately protected against any risk of mechanical damage to which they may be liable in normal condition of handling during transportation, loading, unloading etc.

The cable should be supplied in single length i.e. without any intermediate joint or cut unless specifically approved by the client. Cable shall be supplied in length of 500 meters or as required in SINGLE LENGTH in non-returnable drums of sufficiently sturdy construction. Cable of length more than 250 meters shall also be supplied on non-returnable drums.

The spindle hole shall be 220 mm minimum diameter.

Each drum shall bear on the outside flanges, legibly and indelibly in the English literature. A distinguish number, the manufacturer's name and particulars on the cable i.e. voltage grade, length, conductor size, cable type insulation type and gross weight shall also be clearly visible. The direction for rolling shall be indicating by an arrow. The drum flange also be marked with manufacturer's name and year of manufacturing etc.

**Transportation And Delivery:**

The cable shall be supplied in the actual length as per joint measured at site.

The cable shall be dispatched at client's stores or at site as per detailed instructions given by client at later stage.

The cable shall be loaded from the main vendor's store and properly stacked as per instruction of client's local repetitive.

**Note:**

If cable size mentioned in the tender is other than the standard size as per IS , next higher size shall be considered.

**Cable Terminations:**

Providing end terminations / cable jointing for cables quantity mentioned in above specification including supply of all jointing materials like glands, cable end sockets, lugs etc. The cable glands shall be of double compression sleeve type and lugs shall be crimping type.

**Terminations:**

Provide Aluminium type connectors or cable lugs crimping / solder type at both ends of the cable. However contractor has to provide Bi-metal washer whenever Aluminium and Copper connection will be made. conductivity grease to be used while using crimping type cable lugs/ sockets. The compression tool shall be equipped with attachment which shall assure proper crimping pressure on the connectors.

Connections shall be made tight and insulated with PVC electrical tape of colour as per I.S.

Terminations of cables shall be done by using kits as recommended by the Engineer-in-Charge taking due care as specified by the manufacturer.

Provide a double compression type cable gland at each end of the cable. Glands should be of nickel-plated brass, with PVC shrouds over it. Before applying a PVC shrouds, all bare metal shall be wrapped with pressure sensitive adhesive tape.

**Saddles and Clips:**

Saddles and Clips shall be PVC covered or of G.I. Fixing screws shall be round head brass, where screws are used. Nuts shall be or brass, square pressed type.

**Jointing Sleeves:**

Jointing sleeves shall be of brass with standard termination. Solder type cable connectors / cable sleeves shall be used to joint the cable / conductors. The Solder used shall comply with B.S. 219 type No corrosive flux only shall be used.

**Item No. 152**

**Providing & fitting heavy duty brass cable glands (nickel-plated) with washers & rubber ring conforming to IS, suitable for 3, 3½ & 4 core cables of following type & sizes:**

**Double Compression Brass Cable Glands**

**d) 10 Sq.m.m**

The relevant specifications of Description item No.151 shall be followed.

#### **Item No. 153**

**Cable Terminals (Lugs)**

**Providing & fitting crimping type Cable Terminals (Lugs) conforming to IS of following types and sizes**

**Aluminium Tubular Terminals (Long Barrel) (in Sq. mm.)**

**d) 10 Sq.m.m**

The relevant specifications of Description item No.151 shall be followed.

#### **Item No. 154**

**Providing & laying approved make Double walled corrugated pipes (DWC) of polyethylene(conforming to IS 14930 II )with necessary connecting accessories of same material at required depth for laying of cable. below ground / road surface for enclosing cable**

**(A)50 mm inner dia**

Providing & laying approved make Double walled corrugated pipes (DWC) of polyethylene(conforming to IS 14930 II )with necessary connecting accessories of same material at required depth for laying of cable. below ground / road surface for enclosing cable and back filling the same to make ground as per original. This specification is issued under the fixed serial number followed by the year of adoption as standard or in case of revision, the year of latest revision.

This specification requires reference to the following specifications.

- (i) IS:14930 Pt.-I : General requirements of Conduit system for Electrical and Communication installation
- (ii) IS:14930 Pt.-II : Particular requirements of Conduit system for Electrical and Communication installation
- (iii) IS:2530 : Method for test for Polyethylene moulding materials and polyethylene compounds.
- (iv) IS:7328 : HDPE materials for moulding and extrusion
- (v) IS:12063 : Classification of degrees of protection provided by enclosures of electrical equipment
- (vi) IS:11000(Pt2/Sec1) : Glow-Wire Test and Guidance, Test Methods for Fire Hazard Testing
- (vii) ASTM D 1693 : Test method for environmental stress – cracking of ethylene plastics
- (viii) ASTM D 638 : Standard test method for tensile properties of plastic
- (ix) ASTM D 790 : Test method for flexural properties of Unreinforced and Reinforced Plastics and Electrical Insulating Materials.
- (x) ASTM D 2240 : Standard Test method for Rubber property.
- (xi) ASTM D 648 : Standard Test method for deflection temperature of plastic under flexure load in the Edgewise Position.

Whenever reference to any specification appears in this document, it shall be taken as a reference to the latest version of that specification unless the year of issue of the specification is specifically stated.

#### **1.0 SCOPE**

This document specifies the requirement and testing for Double Walled Corrugated (DWC) HDPE Ducts buried underground including ducts & duct fittings for protection wherever required for all types Cables.

#### **2.0 TERMINOLOGY**

Terminology as defined in IS: 14930 shall be followed.

#### **3.0 ABBREVIATIONS**

- ASTM : American Society for Testing & Materials.
- CC : Cubic Centimetre.

- DSC : Differential Scanning Calorimeter
- DTA : Differential Thermal Analyzer
- DWC : Double Walled Corrugated
- ESCR : Environmental Stress Crack Resistance
- FTIR : Fourier Transform Infrared Spectroscopy
- g : Gram
- HDPE : High Density Polyethylene.
- Hr : Hour
- IS : Indian Standard.
- Kg : Kilograms
- MFI : Melt Flow Index.
- mm : Millimetre
- OIT : Oxidation Induction Test
- SPN : Specification Provisional Number.
- UV : Ultra Violet.

#### **4.0 GENERAL REQUIRMENTS**

4.1 The DWC Duct shall consist of two layers, the outer layer will be corrugated and the inner layer shall be plain and smooth.

4.2 DWC Duct and conduit fittings within the scope of this specification shall be so designed and constructed that in normal use their performance is reliable and without danger to the user or surroundings.

4.3 When assembled in accordance with manufacturer's instruction as part of a conduit system, they shall provide mechanical protection to Cables contained therein.

4.4 Within the conduit system there shall be no sharp edge, burrs or surface projections which are likely to damage insulated conductors or cables or inflict impurity to the installer or user.

4.5 The protective properties of the joint between conduit and conduit fittings shall be not less than that declared for the conduit system.

4.6 The DWC Duct and fittings shall withstand the stresses likely to occur during transport, storage, recommended installation practice and application.

4.7 The DWC duct shall be supplied in continuous length in coil form or straight length, suitable for shipping and handling purpose.

4.8 For conduit systems that are assembled by means other than threads, the manufacturer shall indicate whether the system can be disassembled and if, so, how this can be achieved.

#### **5.0 REQUIREMENTS OF RAW MATERIALS USED FOR THE DWC HDPE DUCTS**

5.1 The base HDPE resin used for the outer and inner layer of the DWC HDPE Duct shall conform to any designation of IS:7328 or to any equivalent standard meeting the requirements given in Table No. 1, when tested as per the standards given therein. However, the manufacturers shall furnish the designation for the HDPE resin as per IS: 7328 as applicable.

5.2 The anti-oxidants used shall be physiologically harmless.

5.3 None of the additives shall be used separately or together in quantities as to impair long term physical and chemical properties of the duct.

5.4 Single pass rework material of the same composition produced from the manufacturer's own production may be used and it shall not exceed 10% in any case.

5.5 The raw material used for extrusion shall be dried to bring the moisture content to less than 0.1%. 5.6 Suitable UV stabilizers shall be used only for manufacture of the non black coloured HDPE duct to protect against UV degradation, when stored in open. The purchaser may ask for UV content test. The test result for UV Content test by FTIR method from any recognized laboratory shall be accepted and the Hindered Amine Light Stabiliser shall be minimum 0.15 %. UV Content test need not to be conducted in case of UV Stabilized raw material is used.

**6.0 REQUIREMENT OF DWC HDPE DUCTS**

6.1 Visual Requirement: The ducts shall be checked visually for ensuring good workmanship that the ducts shall be free from holes, breaks and other defects. The ends shall be cleanly cut and shall be square with axis of the ducts.

6.2 Colour: The colour of the duct viz. Black, Red, Green, Blue, Orange, Violet, Grey, Brown and Yellow. The purchaser shall specify the colour of the duct at the time of ordering.

6.3 Dimensions: The dimensions of the DWC HDPE Ducts shall be as given in table- 2. Any other sizes other than those mentioned in Table- 2 shall be as per the agreement between the buyer and the seller. Compliance shall be checked as per procedure given in Annexure- A

6.4 Standards Length: Duct up to 50 mm OD nominal size shall be supplied in standard length of 100 mtr.  $\pm$  1% or 6 mtr  $\pm$  1 % and all other sizes will be supplied in standard length of 6 mtr.  $\pm$  1%

6.5 Compression Strength: The conduit system shall have adequate mechanical strength. Conduits when bent or compressed either during, or after, installation according to manufacturer's instructions, shall not crack and shall not be deformed to such an extent that introduction of the insulated conductors or cables becomes difficult or that the installed insulated conductors, or cables are likely to be damaged while being drawn in. Compliance may be checked with the application of force which shall be at least 450 N, when reaching the deflection of 5%. Test shall be conducted in accordance to the method given in Annexure- B

6.6 Impact Strength: The conduit system shall have adequate mechanical strength. Conduits when exposed to impact either during, or after, installation according to manufacturer's instructions, shall not crack and shall not be deformed to such an extent that introduction of the insulated conductors or cables becomes difficult or that the installed insulated conductors, or cables are likely to be damaged while being drawn in. Compliance may be checked by ensuring there shall be no crack allowing the ingress of light or water between the inside and outside after the test. Test shall be conducted in accordance to the method given in Annexure- C

6.7 Bending Strength: The conduit system shall have adequate mechanical strength. Conduits when bend either during, or after, installation according to manufacturer's instructions, shall not crack and shall not be deformed to such an extent that introduction of the insulated conductors or cables becomes difficult or that the installed insulated conductors, or cables are likely to be damaged while being drawn in. During the test sample shall not flatten Compliance shall be checked by passing a ball having a diameter equal to 95% minimum inner diameter of the sample declared by the manufacturer, through the sample whilst it is bent around the test apparatus. Test shall be conducted in accordance to the method given in Annexure- D

6.8 Oxidation Induction Test (OIT): The OIT in a qualitative assessment of the level (or degree) of stabilization of material. The induction time in oxygen when tested with an Aluminium pan as per method given in Annexure- E shall not be less than 30 minutes.

6.9 Resistance To Flame Propagation: Non flame propagating ducts shall have adequate resistance to flame propagation. Samples of DWC HDPE Ducts shall be checked by applying a 1KW flame. Test shall be conducted in accordance to the method given in Annexure- F Combustion shall stop within 30 Seconds.

6.10 Carbon Black Content: In case of black coloured duct Carbon Black Content by weight should be between 2 % and 3 %. Test shall be conducted in accordance to the IS: 2530

6.11 Anti Rodent Properties: Safety of ducts from the direct attack of subterranean organism anti rodent material is of utmost importance. These ducts shall be evaluated for their safety against rodents before laying them in the fields. Test shall be conducted in accordance to the method given in Annexure- G

6.12 Resistance to External Influences on DWC HDPE Duct Accessories: The accessories in Clause 7.0 shall be tested for external influences as per IS-12063 for ingress of dust & ingress of water. DWC Duct systems when assembled in accordance with the manufacturer's instructions shall have adequate resistance to external influences according to the classification declared by the manufacturer with a requirement of IP 67. Test shall be conducted in accordance to the method given in Annexure- H

6.13 Marking Identification: The conduit shall be prominently marked at regular intervals along their length of preferably 1m but not longer than 3m using indelible ink with following.

- Manufacturers name
- Specification No.
- Name of the duct with size
- Lot No. of the Product
- Date of manufacture
- Product Length
- Purchaser's Name/ symbol

#### **7.0 DWC DUCT ACCESSORIES**

7.1 The following accessories are required for jointing the ducts and shall be supplied along with the ducts against specific orders. The manufacturers shall provide complete procedure and method for installation of the accessories. The required quantities of accessories are to be mentioned by the purchasing authority in the purchase order.

7.1.1 Plastic Coupler: The coupler shall be of Push-fit type with O-ring. It is used for jointing two or more ducts. The design of this shall be simple, easy to install and shall provide air tight and water tight joint between the two ducts. The coupler shall insure that the two ducts are butted smoothly without any step formation in the inner surface. The coupler may be straight, bands, T-joints type as per requirements of purchaser.

7.1.2 End Cap: This cap made of suitable plastic material shall be fitted on the both ends of duct, coil after manufacturing the duct. This shall avoid entry of dust, mud and rainwater into the duct during the transit & storage.

7.2 The dimensions of accessories shall be suitable for joining the ducts of dimension as per Cl: 6.3

#### **8.0 PACKING REQUIREMENT**

Stores shall be supplied in standard size for delivery and shall be so packed as to permit convenient handling and to protect against loss or damage during transit and storage.

#### **9.0 TYPE TESTS**

9.1 Complete DWC Duct systems for each offered size of the duct on fresh samples shall be subjected to following tests minimum after 240 hrs of manufacture.

- a) Visual Requirement (Cl. No. 6.1)
  - b) Colour (Cl. No. 6.2)
  - c) Dimension (Cl. No. 6.3)
  - d) Standards length (Cl. No. 6.4)
  - e) Compression Strength (Cl. No. 6.5)
  - f) Impact Strength (Cl. No. 6.6)
  - g) Bending Strength (Cl. No. 6.7)
  - h) Oxidation Induction Test (Cl. No. 6.8)
  - i) Resistance to Flame Propagation (Cl. No. 6.9)
  - j) Carbon Black Content (Cl. No. 6.10)
  - k) Anti rodent (Cl. No. 6.11)
  - l) Resistance to External Influences on DWC HDPE Duct (Cl. No. 6.12)
- accessories

9.2 The Oxidation Induction Test, Resistance to Flame Propagating Test, Carbon Black Content Test, Anti Rodent Test on the DWC duct and Resistance to External Influences on DWC HDPE Duct accessories given in Cl. No. 6.8, 6.9, 6.10, 6.11 & 6.12 respectively may be conducted at the manufacturer's laboratory by inspecting authority or at any recognized laboratory.



9.3 The raw material tests of the DWC duct given in Cl. No. 5.0 Table-1 for each grade of raw material shall be conducted. Test may be conducted at the manufacturer's laboratory by inspecting authority or at any recognized laboratory.

9.4 Unless otherwise specified each tests shall be made on three new samples.

#### **10.0 ACCEPTANCE TESTS**

10.1 The following test shall be carried after 240 hrs of manufacture on samples selected from the lot as per sampling plan given in Cl 13.0

- a) Visual Requirement (Cl. No. 6.1)
- b) Colour (Cl. No. 6.2)
- c) Dimension (Cl. No. 6.3)
- d) Standards length (Cl. No. 6.4)
- e) Compression test (Cl. No. 6.5)
- f) Impact test (Cl. No. 6.6)
- g) Bending test (Cl. No. 6.7)
- h) Resistance to Flame Propagation (Cl. No. 6.9)

10.2 The Resistance to Flame Propagating Test on DWC HDPE Duct given in Cl. No. 6.9 may be conducted at the manufacturer's laboratory by inspecting authority or at any recognized laboratory.

10.3 Unless otherwise specified each tests shall be made on three new samples.

#### **11.0 ROUTINE TESTS**

11.1 The following tests be carried out by the manufacturer after 240 hrs of manufacture:-

- a) Visual Requirement (Cl. No. 6.1)
- b) Colour (Cl. No. 6.2)
- c) Dimension (Cl. No. 6.3)
- d) Standards length (Cl. No. 6.4)
- e) Compression test (Cl. No. 6.5)
- f) Impact test (Cl. No. 6.6)
- g) Bending test (Cl. No. 6.7)
- h) Resistance to Flame Propagation (Cl. No. 6.9)

11.2 The Resistance to Flame Propagating Test on DWC HDPE Duct given in Cl. No. 6.9 may be conducted at the manufacturer's laboratory by inspecting authority or at any recognized laboratory.

11.3 The Density and Melt Flow Index tests on raw material of the DWC duct given in Cl. No. 5.0 Table-1 for each grade of raw material shall be conducted.

#### **12.0 INSPECTION**

12.1 All the gauges/ test & measuring instruments shall be under calibration control at the time of inspection and proof to this office shall be produced.

12.2 Inspection and testing shall be carried out by the inspecting authority nominated by the purchaser to ensure that all the requirements of this specification are complied with for the acceptance of the materials offered by the supplier for inspection.

12.3 The purchaser or his nominee shall have free access to the works of the manufacturer and to be present at all reasonable times and shall be given facilities by the manufacturer to inspect the manufacturing of the duct at any stage of manufacture. He shall have the right to reject whole or part of any work or material that does not conform to the terms of this specification or any equivalent specification or requirement applicable and may order the same to be removed / replaced or altered at the expense of the manufacturer. All reasonable/complete facilities considered necessary by the inspecting authorities for the inspection of the ducts shall be supplied by the manufacturer free of cost.

12.4 The manufacturer shall supply the duct samples and samples of the raw materials free of charge as required by the inspecting authority and shall at his own cost prepare and furnish the necessary test pieces and appliances for such testing as may be carried out at his own premises in accordance with this

specification. Failing the existence of facilities at his own premises for the prescribed tests, the manufacturer shall bear the cost of carrying out the tests in an approved laboratory, workshop or test house.

### **13.0 SAMPLING**

13.1 All the length of same nominal size, similar construction and class manufactured from the same material under essentially similar conditions of production shall be grouped together to constitute a lot.

13.2 For judging the conformity of a lot to the requirements of the acceptance tests, sampling shall be done for each lot separately. For this purpose, the number of lengths to be selected at random from the lot shall be in accordance with Table 3.

13.3 These lengths will be selected at random from the lot for taking samples. From each of these lengths, sample of duct shall be taken. The length of the sample shall be sufficient so as to provide test pieces of required lengths as laid down in various test clauses.

### **14.0 WARRANTY**

The manufacturer shall warrant the material covered by this specification to be free from defects in design, material and workmanship under ordinary use and service, his obligation under this warranty being limited to replace free of cost those parts which shall be found defective.

### **15.0 REJECTION**

In case the duct tested and inspected in accordance with this specification, fail to pass the tests or comply with the requirement of the specification, the whole consignment shall be rejected subject to the discretion of the purchaser or his nominee.

### **16.0 INFORMATION TO BE SUPPLIED BY THE PURCHASER**

16.1 Normally the duct will be supplied as per the standard dimensions and length as mentioned in this document. However purchaser may specify his own dimensions/lengths/packing requirements etc. In such cases necessary tolerance shall also be specified by the purchaser.

16.2 Adequate quantity & type of duct accessories shall be supplied along with each lot. Purchasers may specify additional requirement.

16.3 Inspecting agency for acceptance of material. 16.4 Colour of the Duct.

MODE OF MEASUREMENT: AS PER MENTIONED IN SCHEDULE – B Description

Mode of Payment: The rate shall be for a Unit of One Mtr.

### **Item No. 155**

**Providing and erecting Pipe type earthing having 150 cms. long and 2.5 cms. dia. galvanised iron pipe with coupling and buch buried in specially prepared earth pit complete with necessary 8 SWG earth wire.**

#### **GENERAL :**

All the non-current carrying metal parts of the electrical installation and mechanical equipment shall be earthed properly. The cables armoured and sheath, electric panel boards, lighting fixtures, ceiling and exhaust fan and all other parts made of metal shall be bonded together and connected by means of specific earthing system. An earth continuity conductor shall be installed with all the feeders and circuit shall be connected from the earth bar of the panel boards to the conduit system, earth stud of the switch box, lighting fixtures, earth pin of the socket outlets and to any metallic wall plates used. All the enclosures of the motors shall be also connected to the earthing system.

#### **SCOPE OF WORK :**

The scope of work shall cover supply, laying, installation, connecting, testing and commissioning of :

- Earthing station.
- Earthing G.I/Copper strips from earthing station to equipotential bar.
- Earthing G.I/Copper strips/ wires from equipotential bar to lay feeder mains and circuit to connect power panels, DBs, switchboards etc.
- Bonding of Non-current carrying parts, and metallic parts of the electrical installation.

**STANDARDS :**

The following standards and the rules shall be applicable.

- IS; 3043 – 1966 Code of practice for earthing.
- Indian Electricity Act and Rules
- All codes and standards mean the latest.
- Where not specified otherwise the installation shall generally follow the Indian Standard Code of Practice or the British Standard Code of Practice in absence of Indian standards.

**TYPE OF EARTHING STATION :****PLATE EARTHING STATION:**

- The equipment neutral earthing shall be with copper plate earthing station and equipment body earthing shall be with hot dip galvanized iron earthing station.
- The plate electrode shall be 600 x 600 x 3.15 mm copper plate for neutral earthing and shall be of hot dip galvanized iron plate having dimension 450 x 450 x 3.5 mm thick for body earthing.
- The earthing station shall be as shown in the drawing.
- The earth resistance shall be maintained with suitable soil treatment as shown in the drawing.
- The resistance of each earth station should not exceed 1 ohm.
- The earth lead shall be connected to the earth plate through Hot Dip G.I bolts.
- The earthing conductors shall be of copper strip in case of copper earthing and hot dip galvanized iron strip in case of G.I earthing. G.I pipe with funnel of approved quality shall be used for watering the earthing electrodes/station.
- The block masonry chamber with chequered plate shall be provided for hosing the funnel and the pipe for watering the earthing electrodes/ station.
- The hardware and other consumable for earthing installation shall be of copper/brass in case of G.I earthing.
- The link/test pit covers through chequered plate.

**INSTALLATION AND CONNECTION:**

- The plate / pipe electrode, as far as practicable, shall be buried below permanent moisture level but in no case less than 3Mtr below finished ground level.
- The plate / pipe electrode shall be kept clear of the building foundation and in no case; it shall be neared by less than 2Mtr from outer face of the respective building wall /column.
- The plate electrode shall be installed vertically and shall be surrounded with 150 mm thick layers of charcoal dust and salt mixture.
- 20 mm dia. G.I. pipe for watering shall run from top edge of the plate / pipe electrode to the mid level of block masonry chamber.
- Top of the pipe shall be provided with G.I. funnel and screen for watering the earth /ground through the pipe.
- The funnel with screen over the G.I. pipe for watering to the earth shall be housed in a block masonry chamber as shown in the drawing.
- The masonry chamber shall be provide with a cast iron hinged cover resting over the cast iron frame which shall be embedded in the block masonry
- Contraction of the earthing station shall bin general be as shown in the drawing and shall conform to the requirement on the earth electrodes mentioned in the latest edition of Indian standard IS: 3043, Code of Practice for Earthing installation.
- The earth conductor (Strips / wires, G.I. / copper) inside the building shall properly be clamped / supported on the wall with Galvanized iron clamps and hot dip GI screws / bolts. The conductor outside the building shall be laid at least 600 mm. below the finished ground level.

- The earth conductor shall either terminate on earthing socket provide on the equipment or shall be fastened to the foundation bolt and /or on frames of the equipment. The earthing connection to equipment body shall be done after removing paint and other oily substance from the body and then properly be finished.
- Over lapping of earth conductor during straight through in joints, where required, shall be of minimum 75 mm. long.
- The earth conductor shall be in one length between the earthing grid and equipment to be earthed.

**EARTH LEADS AND CONNECTION:**

Earth lead shall be bare copper or galvanized steel as specified with sizes shown on drawings. Copper lead shall have a phosphor content of over 0.15%. Galvanized steel buried in the ground shall be protected with bitumen and Hessian wrap or polythene faced Hessian and bitumen coating. At road crossing necessary Hume pipes shall be laid. Earth lead run on surface of wall or ceiling shall be fixed on saddles so that strip is at least 8 mm away from the wall surface.

The complete earthing system shall be mechanically and electrically bonded to provide an independent return path to the earth source.

Wherever crossing is required, earth jumper shall be of insulated wires.

**EQUIPMENT EARTHING :**

All apparatus and equipment transmitting or utilizing power shall be earthed in the following manner. Copper / G.I. earth strips /wires shall be used unless other-wise indicated in the Schedule B.

**POWER TRANSMISSION APPARATUS:**

Metallic conduit shall not be accepted as earth continuity conductor. A separate insulated continuity conductor of size 100% of the phase conductor subject to the minimum shall be provided.

NOMINAL CROSS-SECTIONAL AREA OF LARGEST ASSOCIATED COPPER CONDUCTOR SQ. MM	NOMINAL CROSS-SECTIONAL AREA OF EARTH-CONTINUITY CONDUCTOR SQ. MM
2.5	2.5
4	4
6	6

The earth continuity conductor be drawn inside the conduit shall be insulated.

Nor metallic conduit shall have an insulated earth continuity conductor of the same size for metallic conduit. All metal junction and switch boxes shall have an inside earth stud to which the earth conductor shall be connected. The earth conductor shall be distinctly colored (green or green / yellow) for easy identification.

Armored cable shall be earthed by two distinct earth connections to the armoring at both the ends and the size of connection being as for the metallic conduit.

In the case of unarmored cable, an earth continuity conductor shall either be run outside along with the cable or should from a separator insulated core of the cable.

Three phase power panel and distribution boards shall have two distinct earth connections of the size correlated to the incoming cable size. In case of single phase of DB's a single earth connection is adequate.

**TEST :**

The entire earthing installation shall be tested as per requirement of Indian Standard Specification IS: 3043. The following earth resistance values shall be measured with an approved earth megger and record.

1. Each earthing Station
2. earthing system as a whole
3. Earth continuity conductors

Earth conductor resistance for each earthed equipment shall be measured which shall not exceed 1 ohm in each case.

Measurements of earth resistance shall be carried out before earth connections are made between the earth and the object to be earthed.

All tests shall be carried out in presence of the consultant/client.

**METHOD OF MEASUREMENT :**

Provision of earthing station complete with excavation, electrode, watering pipe, soil treatment, masonry chamber with cast iron cover etc. shall be treated as one unit of measurement.

The following items of work shall be measured and paid per unit length covering the cost of earth wires / strips, clamps, labour etc.

- a. Main equipment earthing grid and connection to the earthing station.
- b. Connection to the switch board, power panels, DB etc.
- c. The cost of earthing the following items shall become part of the cost of the item itself and no separate payment for earthing shall be made.
- d. Motors- earthing forming part of the cabling/wiring for the motors.
- e. Isolating switches and starters should form part of mounting frame, switch starter etc.
- f. Light fitting- form part of installation of the light fittings.
- g. Conduit wiring, cabling- should form part of the wiring or cabling.
- h. Street lighting- should form part of the street light poles.

**EARTHING STRIPS:**

- Supply, erection, testing and commissioning of earthing strips for connection between LT switch gear, motor, starter as well as transformer neutral and earthing stations
- The earthing strips shall be laid underground or in trenches or on the floor of pump house and hence excavation/ refilling, clamps etc. shall be included.
- The strips shall be finally painted with green colour. The joints shall either be brazed or bolted after tin plating the ends and using GI/brass bolt nut and washers as per direction of engineer –In- charge.
- All equipment earthing joints must be done using nut-bolts and other must be welded. For measurement purpose over lapping of joints shall not be considered and payment shall be made as per actual basis.
- All necessary excavation, refilling shall be in the scope of the work.

**Item No. 156**

**For using salt and charcoal / coke as required for pipe type earthing.**

The relevant specifications of Description item No.155 shall be followed.

**Item No. 157**

**Providing and erecting Sheet Steel powder coated MCB distribution board - flush / surface mounted fitted with busbar, neutral link, earth bar and DIN rail, Conforms to IS 8623-1 & 3, IEC 61439-1 & 3 without MCB to house appropriate nos. of MCBs.(The DBs should be used of same company of MCB to be used) suitable for**

**(b) sheet steel double door (IP-43)**

**(H) Single phase 12 way SS Double door**

Distribution Boards (DB's) shall be suitable for operation on 3 Phase/single phase, 415/240 volts, 50 cycles, neutral grounded at transformer. The DB shall be minimum dielectric strength of 2.5 KV / Sec. All Distribution Boards shall manufactured by a manufacturer listed in Appendix-I.

DB's shall comply with the latest Relevant Indian Standards and Electricity Rules and Regulations and shall be as per IS-8623-1977 (Part-1).

**CONSTRUCTION FEATURES :**

DB's shall be IP 43& made out of high quality CRCA sheet steel and shall be pre-treated and powder coated sheet steel used in the construction of DB shall be folded and braced as necessary to provide a rigid support for all component. DB shall be suitable for indoor / outdoor installation, wall mounting free standing type, in double door construction. The Distribution Boards shall be totally enclosed, completely dust and vermin proof and shall be with hinged doors, padlocking arrangement. All removable/ hinged doors and covers shall be grounded by tinned stranded copper connectors. Distribution Boards shall be suitable for the climatic conditions. Joints of any kind in sheet metal shall be seam welded, all welding, slag shall be rounded off and welding pits wiped smooth with plumber metal. The general construction shall confirm to IS-8623-1977 (Part-1) for factory built assembled switchgear & control gear for voltage up to and including 1100 V AC.

All panels and covers shall be properly fitted and square with the frame, and holes in the panel correctly positioned. Fixing screws shall enter into holes tapped into an adequate thickness of metal or provided with wing nuts. Self threading screws shall not be used in the construction of DBs. Three phase boards shall have phase barriers and a wire channel on three sides. Neutral bars shall be solid tinned copper insulated bars with tapped holes and chase headed screws. For 3 phase DB's, 3. Independent neutral insulated bars shall be provided. All DB's shall be internally pre-wired using copper insulated PVC wires brought to a terminal strip of appropriate rating for outgoing feeders. Knockout holes of appropriate size and number shall be provided in the DB's in conformity with the location of cable/conduit connections. Detachable sheet steel gland plates shall be provided at the top / bottom to make holes for additional cable entry at site if required.

**Distribution Boards shall comprise of the following:**

A panel for mounting where appropriate incoming supply circuit breaker & other auxiliaries for Control & distribution as required.

Installation accessories shall be part of the DB for fixing conductor and rails for mounting MCB's and RCCB's etc.. neutral bus bars & earthing bus bars required in the circuit. All busbars in the FDB shall be insulated type.

Service cable /interconnection shall be part of the Distribution Boards.

The board shall be installed at a height such that the operating is within reach of the normal human height i.e. 1.2 to 1.8 meters from finish floor level.

Phase segregation to be maintained in all three phase distribution boards.

Earthing shall be provided in each FDB's.

**Item No. 158**

**providing and erecting Miniature circuit breaker single pole 6A to 25A suitable to operate on 240 V A.C. system and having breaking capacity 10 KA to be erected in existing box. confirming to IS 8828/1996 with ISI Mark Cat.III**

**MCB**

Miniature Circuit Breaker shall comply with IS-8828-1996/IEC898-1995. Miniature circuit breakers shall be quick make and break type for 240/415 VAC 50 Hz application with magnetic thermal release for over current and short circuit protection. The breaking capacity shall not be less than 10 KA at 415 VAC. MCBs shall be DIN mounted. The MCB shall be Current Limiting type (Class-3). MCBs shall be classified (B,C,D ref IS standard) as per their Tripping Characteristic curves defined by the manufacturer. MCB shall ensure complete electrical isolation & downstream circuit or equipment when the MCB is switched OFF.

The housing shall be heat resistant and having a high impact strength. The terminals shall be protected against finger contact to IP20 Degree of protection. All DP, TP, TPN and 4 Pole miniature circuit breakers shall have a common trip bar independent to the external operating handle.

MCB should be having an integrated label holder with dual side din rail locking facility. Incoming & Outgoing should have facility for termination of Busbar & Cable separately. Cable termination facility should be up to 35 sq. mm.

**Item No. 159**

**Providing & erecting 415V MCB Four Pole Switch for Lighting Load (B curve) having 10KA breaking capacity & confirms to IS :8828 in existing box having following capacity  
(a) 6 to 32 Amp. Cat.III**

The relevant specifications of Description item No.158 shall be followed.

**Item No. 160**

**Providing and erecting Approved make RCCBs conforming to IS: 12640 and having sensitivity of 30 mA and Short Circuit withstand capacity of 10 KA and suitable for operation on 3 phase and neutral 415V,50Hz. having characteristic of quick action & tripping with all advance feature & do not incorporate any electronic component for following Max. rating erected as directed.  
(ii) 40Amps. FP Cat.III**

**I. System of Operation**

Residual Current Circuit Breaker shall confirm to IEC 61008.RCCB shall work on the principle of core balance transformer. The incoming shall pass through the toroidal core transformer.

As long as the currents in the phase and neutral shall be the same, no electro motive force shall be generated in the secondary winding of the transformer. In the event of a leakage to earth, an unbalance shall be created which shall cause a current to be Signature of Contractor generated in the secondary winding, this current shall be fed to a highly sensitive miniature relay, which shall trip the circuit if the earth leakage current exceeds a predetermined critical value. RCCB shall be current operated independent of the line voltage, current sensitivity shall be of 30 / 100 mA at 240/415 volts AC and shall have a minimum of 20,000 electrical operations. It should provide full protection as envisaged by IE rules – 61-A, 71 – ee, 73 – ee, 1985 and also rule 50 of IE rule 1956.

**II. Mechanical Operation**

The moving contacts of the phases shall be mounted on a common bridge, actuated by a rugged toggle mechanism. Hence, the closing /opening of all the three phases shall occur simultaneously. This also shall ensure simultaneous opening of all the contacts under tripping conditions.

**III. Neutral Advance Feature**

The neutral moving contact shall be so mounted on the common bridge that, at the time of closing, the neutral shall make contact First before the phases; and at the time of opening, the neutral shall breaks last after allowing the phases to open first. This is an important safety feature which is also required by regulations. MCB should be having an integrated label holder with dual side din rail locking facility. Incoming & Outgoing should have facility for termination of Busbar & Cable separately. Cable termination facility should be up to 35 sq. mm.

**IV. Testing Provision**

A test device shall be incorporated to check the integrity of the earth leakage detection system and the tripping mechanism. When the unit is connected to service, pressing the test knob shall trip the ELCB / RCCB and the operating handle shall move to the "OFF" position.

**EARTHING**

Earthing shall be provided as per IS:3043-1987.

**PAINTING**

All sheet steel work shall undergo a process of degreasing, pickling in acid, cold rinsing, phosphating, passivating (seven tank processing) and then painted with electrostatic paint (Powder coating). The shade of colour of panel inside/outside shall be as per IS.

**LABELS**

Engraved PVC labels shall be provided on all incoming and outgoing feeder. Circuit diagram showing the arrangements of the circuit inside the distribution panels shall be pasted on inside of the panel door and covered with plastic sheet.

**TESTING**

Testing of panels shall be as per following codes: IS: 8623 (Part -I) 1977 for factory built assemblies of switch gear for voltages upto and including 1000 VAC. IS: 13947 : 1993 Degree of protection

**WIRING**

In wiring a distribution panel it shall be insured that total load of various distribution panel and/or consuming devices is divided evenly between the phases and number of ways as per Consultants drawing.

**Item No. 161**

**Supply, laying, testing & commissioning 1.1 kV grade, XLPE insulated, stranded Aluminium conductor, galvanised steel flat strip / round wire armoured, extruded PVC type ST2 sheathed, heavy duty cable (to be laid on wall surface with necessary clamps / in existing cable trench / cable trays / conduit / pipe sleeves at road crossing or floor as per site requirement) conforming to IS:7098 (Part-1) & IEC:60502 (Part-1) of following sizes:**

**a) 3.5 Core x 25 Sq.m.m**

The relevant specifications of Description item No.151 shall be followed.

**Item No. 162****Cable Terminals (Lugs)**

**Providing & fitting crimping type Cable Terminals (Lugs) conforming to IS of following types and sizes Aluminium Tubular Terminals (Long Barrel) (in Sq. mm.)**

**f) 25 Sq.m.m**

The relevant specifications of Description item No.151 shall be followed.

**Item No. 163**

**Providing & fitting heavy duty brass cable glands (nickel-plated) with washers & rubber ring conforming to IS, suitable for 3, 3½ & 4 core cables of following type & sizes:**

**Double Compression Brass Cable Glands**

**f) 25 Sq.m.m**

The relevant specifications of Description item No.151 shall be followed.

**Item No. 164****LV POWER CONTROL CENTER (PCC)**

**Supply, installation, testing and commissioning LV Distribution Board (LVDB) totally enclosed, dust & vermin proof, indoor type, fabricated from CRCA sheet steel with minimum thickness of 3 mm for base frame / channel / gland plates, 2.0 mm for load bearing members / doors & 1.6 mm for internal partitions, minimum degree of protection - IP 52 as per IS: 2147, suitable for operation on 3-Phase, 4 Wire, 415 V, 50 Hz, Neutral effectively grounded, with instrumentation compartments accomodating meters, aux / protective relays, LED type indicating lamps & control MCBs as per IS: 13947, current & voltage transformers as per IS: 2705, air insulated electrolytic grade Aluminum / Copper bus bar for three phase & neutral system, GI earth bus for entire length, power / control wiring using 1100 V grade, FRLS insulated copper conductor wires conforming to IS: 694 & 8130, equipment fittings, horizontally running busbar compartment height of minimum 300 mm, incoming & outgoing cable connections for 1100 V grade,**



**Aluminium / Copper conductor XLPE / PVC insulated & PVC sheathed armoured cable. LVDB shall have required incoming / bus coupler / outgoing modules of following type & ratings. Above 80 A, upto & including 250 A, 3 & 4 Pole, Air Break Fixed MCCB conforms to IS / IEC 60947-2 with trip free mechanism, current limiting type with Thermal-Magnetic / Microprocessor release (O / C, S / C & E / F) with adjustable settings & having minimum 2NO+2NC potential free auxiliary contacts with all necessary Electro-Mechanical protections & interlocks etc. MCCB module, when used as Incommer / Bus Coupler, shall have enclosure dimensions- 1800(H) x 600(W) x 600 (D) & following technical features:**

**(1.13h) 4 Pole, MCCB with Breaking Capacity of Icu=50 KA at 415V (Ics =100% of Icu), Microprocessor release**

It is to be noted that contractor will get L.T. power supply to run the entire plant after commissioning. This L.T. connection may be obtained from power supply agency or may be from Transformer's L.T. side. H.T. power work like H.T. switchgears, GOD, transformers etc. have not been included in this tender.

General / Details Specifications for MCC Panel for Pump house Panels.

**Scope:**

This scope shall cover design, manufacturer, check test and supply, installation testing and commissioning of Panel Board as described in bills of quantities and drawings. All the Panel Boards will be installed indoor and is connected through the L.T. XLPE cables.

**Service Conditions At Site:**

Ambient Temperature	: Max./Min = 50 deg. C./6 deg. C.
Design temperature	: 55 deg. C.
Relative Humidity	: 95% at 35 deg. C.
Voltage	: 400 +/- 10%
Frequency	: 50 Hz +/- 5%
Neutral	: Solidly/ earthed.
Fault level	: 15 MVA, symmetrical at 400 Volt Solidly earthed.

**Documentation:**

**Vendor shall furnish drawings, data and manuals in three sets along with equipment supplied.**

- General arrangement drawing indicating accessories and dimensions.
- S.L.D.s, three phase wiring diagram, control wiring
- Foundation plan and loading
- Termination arrangement with dimensions.
- Documents to be submitted after placement of order
- As per 3.1 above for comments and approval for manufacturer.
- Schematic and sectional drawing.
- Bill of quantity as well as make of material with Cat. No. for each item for all the panels.
- Final Documents
- Final wiring diagram of the Panel (power and control circuit with ferrule number) with Reproducible Tracing Paper(RTF)/C.D.s & in 3 hard copies
- Instruction and Maintenance Manuals – three copies.
- Test certificates – three Copies

**General Specifications:**

All the metal clad totally enclosed, rigid floor(MCC), air insulated, cubical type suitable for operation for three phase/single phase, 415/240 Volt, 50 Hz, Neutral effectively grounded at transformer.

The panel shall be IP54 protection class construction. It should be either "Front operated and maintained" or "Front operated and back maintained", as per the site conditions.

The painting of all the metal part shall be as per the painting specification as defined in the datasheet.

The panel shall be designed to withstand the heaviest condition at site, with maximum ambient temperature of 50 deg C., 95% Humidity.

**Standards And Codes:**

The panels shall comply with the latest edition of relevant Indian Standards and Indian Electricity rules and Regulations. The following Indian standards shall be complied with :

IS :4237 General recruitment for switchgear and control gear for voltages not exceeding 1000 V A.C. or 1200 V D.C.

IS : 5578 Guide for marking of insulated conductor.

IS : 22353 Guide for uniform system of marking and identification of conductors and apparatus Terminals.

IS : 13947 Low voltage switchgear and control gear.

IS : 8197 Terminal marking for electrical measuring instrument and their accessories.

IS : 2551 Danger Notice plates.

IS : 10228 Code of practice for selection, Installation and maintenance of switchgear and control gear.

IS : 8623 Specification for factory built assemblies of switchgear and control gear for voltage up to and including 1000 V A.C. and 1200 V D.C.

IS : 8828 Miniature Circuit Breakers.

IS : 9224 Low Voltage Fuses

IS : 2705 Current Transformers

IS : 3156 Voltage Transformers

IS : 3231 Electrical Relay for protection

IS : 1248 Indicating Instruments

IS : 722 Integrating Instruments

IS : 6875 Control switches and push buttons

IS : 1822 A.C. motor starters of voltage not exceeding 1000 v0lt

Indian Electricity Act and Rules( AS amended up to date ) and approval of FIA of India. The panel also requires approval of the department at various stages of manufacture ring such as design, selection, construction, testing, shipping etc.

**Construction:****Cubical Type Panel:****Structure**

The panels shall be of compartmentalized design so that circuit arc/flash products do not create secondary fault and be fabricated out of high quality CRCA sheet, suitable for indoor installation, "Front operated and maintained" or "Front operated and rear maintained" as per site requirement, extensible and floor mounting type.

All CRCA sheet steel used in the construction of panels shall be 14SWG thick and shall be folded and braced as necessary to provide a rigid support for all components. The door and partition sheets shall be at least 16 SWG thick. Joint in any kind of sheet steel shall be seam welded, as welding slag grounded off and welding pits wiped smooth with plumber metal.

The panels shall be totally enclosed, completely dust and vermin proof and degree of protection being not less than IP : 54. Gaskets between all adjacent units and beneath all covers shall be provided to render the joints dust proof. All doors and covers shall be fully gasket with foam rubber and /or rubber strip and shall be lockable.

All panels and covers shall be properly fitted and screwed with the frame and holds with the panel correctly positioned. Fixing screw should be entered into holes, taped into an adequate thickness of metal or provided with bolts and nuts. Self threading screws shall not be used in the construction of panels.

A base channel of 75 mm \* 50 mm \* 6mm thick shall be provided at the bottom of the lower most unit shall be provided.

The main panel shall be preferably arranged in multi-tier formation. The panel shall be of adequate size based on outgoing feeders required as shown in the drawing. The size of the panel in designed in such a way that the internal space is sufficient for hot air movement and the electrical components does not attain

temperature more than 50 deg. C.. Openings shall be provided for natural ventilation, the said openings shall be screened with fined G.I. weld mesh. The entire electrical component shall be rated for 50 deg. C. Alternatively the panel shall be provided with removable sheet steel plates at bottom to drill holes for cable/conduit entry at site. The panel shall be designed to facilitate easy inspection, maintenance and repair. The panel shall be sufficiently rigid to support the equipment without distortion under normal and under short circuit conditions. They should be suitably braced for short circuit duty.

**Painting:**

The painting shall be seven-tank process with powder coating and as mentioned in the data sheet.

**Circuit Compartments:**

Each circuit breaker and switch fuse unit shall be housed in separate components and shall be enclosed on all sides. Sheet steel hinged lockable door shall be duly interlocked with the breaker/ switch fuse unit in "ON" and "OFF" position. Safety interlocks shall be provided for air circuit breaker to prevent the breaker from being drawn out when the breaker is in "ON" position.

The door shall not form an integral part of draw out position of the circuit breaker. All instruments and indicating lamp shall be mounted on the compartment door. Sheet steel barrier should be provided between the tiers in the vertical section.

**Instrument Compartments:**

Separate adequate compartment shall be provided for accommodating various instruments. These components shall be accessible for testing and maintenance without any danger of accidental contact with live parts of the circuit breaker/switch fuse unit, bus bar and connections.

**Bus Bars:**

The bus bar shall be air insulated and made of high quality, high conductivity high strength electrolytic copper only with heat shrinkable sleeve of high dielectric strength in different colour.

The bus bar shall be of 3 phases and neutral system with separate neutral and earth bar. The bus bar and interconnection between bus bars and various components shall be of electrolytic Copper only. The bus bar shall be of rectangular cross section design to withstand full load current for phase bus bar and half rated current for neutral bus bar in MCC panel and shall be extensible on both the sides. The bus bar size shall be as per current density 1.5 Amp./sq mm. The bus bar shall have uniform cross section through the length.

The bus bar and interconnections shall be insulated with epoxy coated bus sleeves and supported on bus insulators on DP - DNH/DMC type at sufficiently close intervals to prevent busbar sag and shall effectively withstand electromagnetic stresses in the event of short circuit capacity of 50KA RMS symmetrical for 1 second and a peak short circuit withstand of 105 KA minimum.

The bus bar shall be housed in a separate compartment. The bus bar shall be isolated to avoid any accidental contact. The bus bar shall be arranged such that minimum clearances between the bus bar are maintained as below.

Between Phases	: 25 mm. minimum
Between Phases and neutral	: 25 mm.
Between Phases and earth	: 25 mm.
Between neutral and earth	: 20 mm. minimum

All bus bar connections shall be done by drilling holes in bus bar and connecting by chromium plate or tinned plated brass bolts and nuts. Additional cross section of bus bar shall be provided in all panels to cover up the holes drilled in the bus bar.

All connections between bus bars and circuit breakers/ switches and cable terminal shall be through Copper strips of proper size to carry full rated current. These strips shall be insulated with insulating tapes.

Panel to Panel bus bar entry should be effectively sealed by electrical and thermal insulation barriers so that products of flash over should not travel from one panel to another panel creating multiple faults.

**Electrical Power And Control Wiring Connection:**

Terminal for both incoming and outgoing cable connections shall be suitable for 1100 V grade, aluminium / copper conductor XLPE insulated and PVC sheathed, armoured cable and shall be suitable for connection of solder less sockets for the suitable size and type of cable. Both control and power wiring shall be brought out in cable alley for ease of external Connections, operation and maintenance.

10% or 2 nos. whichever is higher, spare terminals shall be provided on each terminal block, so that not more than one outgoing wire is connected per terminal. Suitable barriers of enclosures shall preferably separate terminal strips for power and control from each other. Wiring inside the modules for power, control, protections and instruments etc. shall be done with use of 660/1100 V grade FRLS insulated copper conductor wires conforming to IS : 694 and 8130. Power wiring inside the starter module shall be rated for full current rating of respective contactor, but not less than 4.0 sq. mm. cross section areas. For current transformer circuit 2.5 sq. mm. copper conductor wires shall be used. Other control wiring shall be done with 1.5 sq. mm. copper conductor wires. Wires for connections to the door shall be flexible. All conductors shall be crimped with solder less socket at the end before connections are made to the terminals.

Control power supply to modules through the control transformers only. Control power wiring shall have control fuses,(HRC fuse type)/2 Amp. MCB for circuit protection. All indicating lamps shall be protected by HRC fuses.

Identification ferrules shall be fitted to all the wiring termination for ease of identification and to facilitate checking and testing.

Spring type washer shall be used for all copper and aluminium connections.

**Terminals:**

The outgoing terminals and neutral links shall be brought out to a cable alley suitably lockable and accessible from the panel front. The current transformer for instruments metering shall be mounted on the disconnecting type terminals blocks. No direct connection for incoming or outgoing cables to internal components of the distribution board is permitted; only one conductor may be connected in one terminal.

**Wire ways**

A horizontal/vertical box type PVC channel wire ways shall be provided to take interconnecting control wiring between different vertical sections.

**Cable Compartment**

Cable compartment of minimum 450 mm size shall be provided in the Panel for easy termination of all incoming and outgoing cables entering from top or bottom. Adequate supports shall be provided in the cable compartment to support cables. All outgoing and incoming feeder terminals shall be brought out to terminal blocks in the cable compartment.

**Earthing:**

Cu earth bars of suitable size 25x6 mm shall be provided in the panels for the entire length of the panel. Provisions for the connection of this earth bar to the main earthing station/bar. The frame work of the panel as well as each feeder door earthing shall be connected to this earth bar.

The earth continuity conductor of each incoming and outgoing feeder shall be connected to this earth bar. The arm our shall be properly connected with earthing clamp, and the clamp shall be ultimately bounded with the earth bar.

**Labels:**

Engraved metallic labels shall be provided on all incoming and outgoing feeders. Single line circuit diagram showing the arrangement of circuit inside the distribution board shall be pasted on inside of the panel door and covered with transparent laminated plastic sheet.

**Name Plate:**

A metallic name plate with the panel's designation with the bold letters shall be fixed at top of the central panel. A separate name plate giving feeder details shall be provided for each feeder module door.

Inside the feeder compartments, the electrical components, equipment, accessories like switchgear, control gear, lamps, relays, etc. shall suitably be identified by providing stickers.

**Danger Notice Plates:**

The metallic danger notice plate shall be affixed in a permanent manner on operating side of the panel indicating danger notice in both Hindi and English and with a sign of skull and bones and shall be of ISI certification mark.

**Internal Components:**

The panel shall be equipped complete with all types of required number of Air Circuit Breakers, switch fuse units, contactors relays, energy meters, fuses, meters, instruments, indicating lamps, push buttons, equipment fittings, bus bars, cable boxes, cable glands etc. and all the necessary internal connections/wiring as required and as indicated elsewhere.

All parts of the Panels carrying current including the components, connections, joints and instruments shall be capable of carrying their specified rated current continuously, without temperature rise exceeding the acceptable values of the relevant specifications at the parts of the panels. All units of the same ratings and specifications shall be fully interchangeable.

**Components:****General:**

The type, size and rating of the components shall be as indicated. While selection of the capacity of the components resulting from the prevailing conditions like ambient temperature shall be allowed for the thermal and magnetic trip rating shall be compensated for the ambient temperature.

The ratings indicated on the drawing are ratings anticipated at prevailing site conditions.

**Switch Disconnecter Fuse Units:**

The fuse switch units shall be 3 pole, double break type heavy duty suitable for load break duty (AC 3), and quick make and break action. Separate neutral link shall be provided in the switch. All switch fuse units shall be duly interlocked with operating mechanism so as to prevent opening of the door when the switch is in ON position and also prevent closing of the switch when the door is not properly secured. All contacts shall be silver plated and all live parts shall be shrouded. The incoming and outgoing terminals of the switch shall be adequately sized to receive proper of the cables. High rupturing capacity(HRC) fuse links shall be provided with switch fuse units and shall be in accordance with IS : 9224-1979 and having rupturing capacity of not less than 35 MVA at 415 V. When switch is in "OFF" position the fuse shall be isolated from both the ends. HRC fuse links shall be provided with visible indicators to show that they have operated. The switch dis-connector fuse unit shall be manufactured in accordance with IS : 13947.

**Contactors:**

It shall be suitable to soft starter ampere rating or motor ampere rating, Continuous duty, 440 V, 50 Hz with 2 NO+ 2NC & necessary safety features. Wherever contactors are required for capacitors, it shall be Capacitor Duty contactor and accordingly, rating shall be selected. Exact rating shall be finalized at the time of detailed engineering.

**Air Circuit Breaker:****Construction:**

The ACB shall be having following features.

- Draw out type Mechanical with suitability of various positions (such as "test" and "maintenance") and its indicators.
- Safety shutter of Fiber glass/polycarbonate sheet of 2 mm thickness shall be provided.

Mechanically trip free plus anti pumping shall be provided with relay ONLY and not by contactors.

- Door interlock with defeat features to be provided.
- ACB shall be lockable in isolation position.
- Power circuit breakers shall comply with standards IEC 60947-1&2 or standards derived from the latest amendments.
- The circuit breakers shall have a 50KA breaking capacity or more if not justified by calculations taking into account their installation location.

Specification for Microprocessor based over current releases for ACB's:

If anyone phase is loaded to 20% of the rated current of the current transformer installed it should be sufficient for the release to operate the release should offer the following minimum protection functions:

**Overload (L):**

Thresholds –Current setting -  $I_r - 40\%$  to  $100\%$  of  $I_n$  rating, Time delay - 0.5 seconds to 24 seconds @ 6  $I_r$ . It should be True RMS Long time Protection

**Selective Short circuit (S):**

Pick up Settings –4 to 10 times of  $I_r$ . (Min 9 Thresholds)

Time delay at 10  $I_r$ . - 50 ms to 500 ms with I2t ON

User may facilitate to bypass the protection if required.

**Instantaneous short circuit (I):**

Should be from 2 to  $15 \cdot I_n$ .

User may facilitate to bypass the protection if required.

Accuracy of Instantaneous tripping -  $\pm 10\%$

**Ground Fault (G):**

Current Threshold: Should be Settable.

Time Threshold: Should be Settable

User may facilitate to bypass the protection if required.

**Neutral Protection:**

Following is required

Neutral Unprotected: At 0.5  $I_n$ , At  $I_n$  Important Parameters

Sr No	Parameters	ACB
1	Rated Operating Voltage	500V
2	Rated Insulation Voltage	1000V
3	Rated Impulse Withstand voltage	8kV
4	Rated ultimate short ckt breaking capacity @ 415V	50kA
5	Rated Short time withstand current for 1sec	35kA
6	Rated Short time withstand current for 3 Seconds	Min 35 KA
7	Rated short circuit making capacity @ 440Vac	120kA
8	Utilization category	B
9	Mechanical Life operations without Maintenance	12500
10	Mechanical Life operations with Maintenance	20000
11	Electrical Life operations @ 440V without maintenance	10000
12	Power Loss @rated current for 3/4 pole	To be mentioned by bidder

**Construction**

As per Standard practice

Electrical Auxiliaries

All electrical auxiliaries shall be installable in a compartment which, under normal operating conditions, shall not contain any conducting parts capable of entering into electrical contact with the circuit-breaker poles. It shall be possible to connect all auxiliary wiring from the front of the circuit breaker.

**Mechanical indicators**

Mechanical indicators on the front panel of the power circuit breakers shall indicate the following status conditions:

	<b>Parameters</b>	<b>MCCB</b>
1.	Rated Operating Voltage	415 V
2.	Rated Insulation Voltage	690 V
3.	Rated Impulse Withstand voltage	8 kV
4.	Rated ultimate short ckt breaking capacity @ 415V	35 kA
5.	Rated Short time withstand current for 1sec	35kA
6.	Rated Short time withstand current for 3 Seconds	--
7.	Rated short circuit making capacity @ 440V ac	105kA
8.	Utilization category	A
9.	Mechanical Life operations w/out Maintenance	4000
10.	Mechanical Life operations with Maintenance	4000
11.	Electrical Life operations @ 440V without maintenance	4000
12.	Number of poles	3 or 4 as applicable

The MCCB shall be with protections and having suitable setting range with 2NO+2NC auxiliary contacts.

#### **Digital Multifunction Meter**

A separate/external energy meter having class: 1 accuracy local display. It must have RS485 Modbus port to enable transmission of minimum following data.

- Current in all phase
- Phase as well as line Voltage
- KW, KVA, KVAR
- Harmonic distortion
- Power Factor
- Frequency

It should be installed in the LT Panel's cubical in such a way that all the settings can be done without opening of cubical door.

#### **Voltmeter & Ammeter**

They shall be digital flush mounting type. The dial of the meter shall be square in the shape of 96 \* 96 mm and suitably ranged.

The voltmeter selector switch shall be arranged to provide line to line voltage reading and line neutral voltage. Separate current transformer shall be provided for all ammeters.

#### **Kwh Meter:**

KWH meter shall be of suitably ranged, flush mounting, 433 volts 50 c/s, 3 phase 4 cycle, unbalanced load type with metering class and with suitable CTs.

#### **Current Transformer:**

Where ammeter/KWH meter are called for, cast resin type class 1 and suitable VA burden C.T.s shall be provided for current/energy measurement. Current transformer shall be in accordance with IS: 2705-1992 as amended up to date.

#### **Push Buttons:**

The push button unit shall be comprised of the contact element, a fixing holder and a push button actuator. The push button shall be momentary contact type. The contacts shall be of silver alloy and rated at 10 amp.

continuous current rating. The actuator shall be of standard type and colour as per its usage for ON, OFF and TRIP.

**Indicator Lamps:**

Indicator assembly shall be screw type with built in resistor having non fading colour lens. LED type lamps are required with standard color practices.

**Motor Protection Relay ( $\mu$ P Based)**

Motor protection relays (MPR) shall be provided for all motors rating as per the quantity stated at each Starters. MPR shall be micro computer based and of required range as per motor rating at site, which bidder shall evaluate on his own at site if required before submitting his bid, with necessary selectable CTs and communication port for communication with PLC/SCADA, etc. complete in all respects.

Necessary connection with communication network (Provisional) of PLC shall be carried for monitoring the motor status in real time trends and historical data

**It shall be**

- Computerized 3 phase protective Device
- Suitable range as per motor rating
- Selectable Scrolling time
- Settable and accurate Overload and Under current protection with Annulation
- Selectable Under current time
- Current based single phase loss protection with Annunciation and selectable protection time
- Locked rotor protection with annulation with stable range 4 to 10 times.
- Earth Fault Protection with Annulation
- Settable earth Fault current
- Current Based phase Reversal protection with Annulation
- LCD Display with current value of all three phase.

It shall be complete man-Machine interface with suitable software calibration facilities and ease of wiring.

**Change Over System (Ats) Specification:-**

It shall be Four-pole, 415V, 50 Hz, change over type Auto transfer switch (ATS) shall be operated through solenoid or electrical motor. It shall be conforming to IEC-947-1 and IEC Page 400 947-6-1. Transfer time from one source to another source shall be less than 100 milliseconds. Rated Insulation voltage of each ATS should be 1000 V, Rated making and breaking capacity of ATS shall be minimum 10 x In and 8 x In respectively. The switch should be capable to withstand switching frequency of 150 operations per hour. The operating voltage of operating coil of switch should be 220 V.

ATS shall have three positions; main supply side, stand supply side and in isolate position. ATS shall have necessary devices for monitoring supply circuits and transferring one or more from one supply to another. The closing command should be through a solenoid coil supplied with 220 V AC. The operating mechanism always responds by closing on the main supply side and not on to the standby supply side, when both supplies are present. The tripping coil, when energized, is used to bring the ATS to off / Neutral position. ATS shall have facility to operate manually, as an on load change over switch. It shall have three positions; main supply side, stand supply side and in isolate position. There should be primary side protection against single phasing, over voltage and under voltage. Auto Transfer Switch should be a dual facility to switch ON /OFF from one power source to another either in Automatic or in Manual mode depending upon the application, therefore a selector switch with Auto/ Manual facilities. This shall be fitted with common load terminal of ATS. One side of ATS shall be connected with Main Supply source and other side of ATS shall be fitted with Generator power supply source.

**Shop Drawings:**

Prior to fabrication of the panels the supplier / contactor shall submit for consultant's approval the shop/vendor drawing consisting of G.A. drawing, sectional elevation, single line diagram, bill of material etc. and if design calculation indicating type, size, short circuit rating of the electrical components used, bus



bar size, internal wiring size, panels dimensions, colour, mounting details etc. in 6 sets. The contractor shall also submit manufacturer's catalogues of the electrical components installed in the panels along with the drawing.

**Inspection:**

At all reasonable times during production and prior to transport of the panels to site, the supplier/contractor shall arrange and provide all the facilities at their plant for inspection and routine test.

**Test Certificates:**

Testing of panels shall be carried out at factory and at site as specified in Indian Standards in the presence of engineer in charge /consultant. The test result shall be recorded on a prescribed form. The test certificate for the test carried out at factory and at site shall be submitted in duplicate.

**PMCC / MCC PANELS:**

Following Minimum new PMCC / MCC Panels shall be provided by the tenderer, if additional MCC panels required as per design, same shall be provided by the tenderer. This details given only for guidance to tenderer, actual quantity shall be decided during detailed engineering.

The MCC shall have degree of protection of the enclosure IP-54. The M.C.C. shall be of draw out and extensible type. The lighting boards shall not be draw-out type. Main PMCC Panel for STP shall be double busbar type. One busbar is utilised for Torrent power supply & another busbar is utilised for Bio Gas generator power supply. Necessary interlocking arrangement shall be provided between both power system.

The MCC shall be free standing, extensible, metal enclosed fixed compartment - tailed, modular type, dust and vermin proof suitable for indoor installation. The switchgear shall be assembled out of vertical panels of uniform height not exceeding 2450 mm. The maximum height of the operating handle/switches shall not exceed 1800 mm and the minimum not below 300 mm.

The switchgear shall be designed to ensure max. safety during operation, inspection, connection of cables relocation of outgoing circuits and maintenance with the energised bus system and without taking any special precautions. The switchgear shall permit max. interchangeability and shall be extensible on either side

The switchboard / MCC shall be sheet steel clad with the frame fabricated out of 14 SWG cold rolled sheet steel and doors/ covers also of 14 SWG cold rolled sheet steel having integral base frame for each vertical panel. All hardware shall be corrosion resistant. All joints and connections of the panel members shall be made of galvanized and passivated or cadmium plated high quality steel bolts, nuts and washers secured against loosening.

The switchgear shall be suitable for bottom cable entry. Each MCC panel shall have a separate cable alley of 150 mm minimum width. Motor starter and switch fuse units shall be in Multitier arrangement in single fixed execution. All auxiliary devices for control, indication, measurement and protection such as push buttons, control and selector switches, LED type indicating lamps, Digital metering instruments shall be mounted on the front side of the respective compartment. Components requiring frequent inspection during operation shall be provided with an anti-corrosive heater rated for 240 AC +/-10% supply with a switch, fuse and a thermostat.

MCC must incorporate all the feeders required for above mention capacity including spare feeders as mentioned elsewhere in this tender. All the busbars including main busbars must be designed as per the rating of conserend /associated switchgear.

Main bus bars shall be of high conductivity having uniform current rating throughout the length. Horizontal and vertical bus bars shall be sized depending upon the max. expected current and to limit the max. operating temperature at specified design ambient temperature to 85 deg. C for normal operating condition and the 200 deg. C for short circuit condition considering installation in poorly ventilated area.

Adequately sized (taking current density 1.5 Amp/Sq.mm.) Electrolytic Tinned Copper ( Cu.) busbars with heat shrinkable coloured sleeve running horizontal in a separate enclosure shall be provided for space heaters, control supply and meter requirements. Necessary tee-off connections shall be used for distributing auxiliary supply to each vertical panel. All busbars shall be colour coded and designed to withstand specified short circuit current for one second. Copper used must be electrolytic tinned copper only.

Copper earth bus shall be adequately sized and provided throughout the length of the switchboard with provision for interconnection to earthing grid. All non-current carrying metal parts of the mounted equipment shall be earthed. Doors and moveable parts shall be earthed using flexible copper connections. All feeders must be separated using metal partitions

Inside the switchboard, the wiring for power control, protection and instruments circuits shall be done with PVC insulated copper conductors having 660/1100 V grade insulation. Min. size of control wire shall be 1.5 mm<sup>2</sup> copper for circuits having MCB'S rating of 10 Amps. or less. For higher MCB'S rating control circuits, min. 2.5 mm<sup>2</sup> copper conductor shall be used.

'Elemex' type terminals shall be acceptable for wires upto 10 mm<sup>2</sup> size and for conductors larger than 10 mm<sup>2</sup> bolted type terminal with crimping lugs shall be provided. Each wire shall be terminated at a separate terminal.

All motor starter shall be D.O.L. type and upto 7.5 H. P. and star-delta type above 7.5 H.P. unless otherwise specified. All the cast resin C.T.'s and energy meter must be of accuracy class 0.5.

All switches/MCCB shall be load break, heavy duty, air lock type with 2NO + 2NC the operating handle mounted on the compartment door complete with necessary interlock and defeat mechanism. All fuses shall be non-deteriorating HRC cartridge pressure filter, link type the connector shall be air lock type having AC-3 duty rating.

Micro processor Based Motor protection relays with over load, short circuit, single phasing, earth fault, Reverse rotation protection shall be used for motor rating above 7.5 H.P.

All Digital indicating instrument shall be moving iron flush mounting type of 96 x 96 mm sq. pattern. However 72 x 72 mm instruments may be acceptable for outgoing feeders in the MCC. All control/selector switches shall be rotary back connected type having a cam operated contact mechanism with pistol grip handle for circuit breaker control and knob type handle for other applications. All motor starter feeders shall have stop push buttons and trip indication lamps. Incomer to MCC shall have a 415 V MCCB / TPN with primary fuse, secondary MCB along with a voltmeter and a selector switch. The incomer to MCC shall have Digital KWH meter with protection MCB's etc. to record energy consumed in the plant including lighting for the plant. A separate Digital KWH meter may be used for the lighting consumption. Accuracy class of Digital KWH meter and CT's must be 1.0. All CTS used in panel must be resin cast type.

All metal parts shall be thoroughly cleaned degreased and made free from rust. After application of the primer, the switchboard shall be spray painted with two coats of final paint colour shade.

Micro processor Based Motor protection relays with over load, short circuit, single phasing, earth fault, Reverse rotation protection shall be used with all motor starters above 7.5 HP motors.

A centrally located engraved nameplate shall be provided for the switchboard. Each module shall have engraved nameplate bearing data as per approved drawings. Nameplate or polyester adhesive stickers shall be provided for each equipment mounted on the switchboard. One feeder of each rating must be provided in the switchboard as a spare feeder. The contractor shall have to submit the G.A. Drawing/and/or single line diagram of MCC showing the feeder arrangements along with the technical bid.

#### **General Requirements of The Panel:**

- The tenderer must have CPRI approval for manufacturing panel for the tenderer, who has not CPRI approval has to make panel from CPRI approved panel manufacturer only and that case contractor has to submit the details of Panel Manufacturer.

- 125 amp and above capacity MCCB must be complete with the operating handle interlock,
- All the L.T. switch gear unit should be confirm to IS-13947.
- All the CT's shall have cast resin type only and each CT should have short link.

Indication lamp shall be LED type panel mounted, low power consumption, Min.100000 hrs. of Life, O/L and S/C protected with its holders etc. Suitable for specified voltage shall be used.

- All the measuring instruments should be of Accuracy Class 1.0.
- Each door of the panel should be earthed separately by Flexible link.
- The above cubicle pattern L.T. switch board comprising of Incoming and Outgoing described above must be complete with necessary floor stands, foundations bolts, copper inter connections between bus bars and incoming / outgoing, inter wiring with PVC copper cables, labels marked for incoming /outgoing / earthing terminal etc. and other required major / minor items.
- All internal wiring work should be permanently marked / labelled at terminations with numbers or letters corresponding to diagram.
- A copper earth bus of appropriate size must also run throughout the panel.
- All the MCCBs should be with front operated mechanism with 2 NO + 2NC Auxiliary contact.
- Ample space in each compartment shall be provided for easy maintenance and repairing.
- Control supply of each individual starter feeder shall be protected with the suitable capacity of the MCB.
- Auto Manual switch should be provided for each pump set outgoing feeder.
- Operating handle of switch gear, control unit for panel shall not be above 1.8 Mtr. From operating platform.

#### **Item No. 165**

##### **Cantilever Office Chair Non-revolving and non-tilting chair with armrest**

The work of furniture shall be carried out as per direction of Engineer in charge

#### **Item No. 166**

##### **Revolving Chair with Center tilt mechanism Designed with 360 degree-revolving type**

The work of furniture shall be carried out as per direction of Engineer in charge

#### **Item No. 167**

##### **Executive Table with One side pedestal unit. Two legs with Gable end and modesty panel**

**Width 1200 X Depth 600 X Height 750 (mm)**

The work of furniture shall be carried out as per direction of Engineer in charge

#### **Item No. 168**

##### **Almirah Steel shelving cabinets conforming to BIS specification IS: 3312:2021 (with latest amendment).**

**Width 910 X Depth 480 X Height 1830 (mm) for Storage**

The work of furniture shall be carried out as per direction of Engineer in charge

#### **Item No. 169**

##### **3 Seater Sofa With Leatherite Cover Length 1980 X Depth 775 X Height 800 (mm)**

The work of furniture shall be carried out as per direction of Engineer in charge

#### **Item No. 170**

**RO & UV both ABS grade plastic Drinking Water Coolers with built in Water Purification System with storage capacity of 120 Liters. Purification Capacity of 15 Liter/ Hr and Cooling capacity of 50 Liter/ Hr.**

The work of furniture shall be carried out as per direction of Engineer in charge

## 16.0 IMPORTANT INSTRUCTION TO TENDERER

**NAME OF WORK :-** “ CONSTRUCTION OF STORE AREA FOR DRAINAGE DEPARTMENT, BMC AT F.P. NO. 66 UNDER T.P. SCHEME NO. 7 ADHEWADA, BHAVNAGAR ”

1

Affix latest passport size photo of tenderer
---

-----  
 Specimen Signature of the Contractor

2.

1	2	3	4
AFFIX LATEST PASSPORT SIZE PHOTOGRAPH OF ALL PARTNERS IN CASE OF PARTNERSHIP AGENCY			

Specimen signature of all partners in case of partnership agency.

1. \_\_\_\_\_

2. \_\_\_\_\_

3. \_\_\_\_\_

4. \_\_\_\_\_

Submission of Registered Agreement is compulsory in case of partnership agency.

5. Submission of sale tax certificate, with proof of residence is compulsory for tenderer.
6. In case of Government royalty applicable to tenderer, it is compulsory to submit a receipt of royalty payment with tender.
7. The Photograph and specimen signature of contractor will be cross checked, whenever contractor receives payment in account section of BMC.
8. The specimen signature of contractor will be cross checked by Account Department of BMC, in case of representative of Contractor along with letter of authority of a person who signed an agreement, receives payment.
9. In case of octroi applicable to the goods of supplier/tenderer, the tenderer/supplier has to submit an attested copies of Xerox of all octroi receipts.

10. All partners of tenderer should put their specimen signature at the relevant places in the tender. A Passport size photograph of all partners who have signed the tender shall be affixed in the tender. The successful tenderer shall be required to execute necessary agreement where in the same partners shall put on their signatures.

SIGNATURE OF THE CONTRACTOR.

EXECUTIVE ENGINEER,  
BHAVNAGAR MUNICIPAL CORPORATION,  
BHAVNAGAR

## 17.0 ADVANCE STAMP RECEIPT

Received with thanks the sum of Rs. \_\_\_\_\_ (In Words \_\_\_\_\_  
\_\_\_\_\_) only from the Bhavnagar  
Municipal Corporation being the refund of Earnest Money Deposit placed by me / us vide BMC's Receipt  
No. \_\_\_\_\_ dated \_\_\_\_\_ alongwith the tender paper for the  
\_\_\_\_\_  
(Name of the work)

Date : \_\_\_\_\_ Revenue Stamp

Signature of the Tenderer

f.w.c. to the Accountant,

2. For remarks whether the \_\_\_\_\_ deposit amounting toRs.  
\_\_\_\_\_ placed on \_\_\_\_\_ by Shri / M/s.  
\_\_\_\_\_ in connection with the work of  
\_\_\_\_\_  
\_\_\_\_\_ stands in full in the name of the aforesaid party (R.No. \_\_\_\_\_ dated  
\_\_\_\_\_).

EXECUTIVE ENGINEER,  
BHAVNAGAR MUNICIPAL CORPORATION,  
BHAVNAGAR.

F.W.Cs. to EXECUTIVE ENGINEER ,

To deposit of Rs. \_\_\_\_\_ placed on \_\_\_\_\_ by  
Shri/M/s. \_\_\_\_\_ stands in full  
in the name of the aforesaid party.

Accountant.

Submitted,

For favor of sanction of refund Rs. \_\_\_\_\_ being the amount of \_\_\_\_\_ deposit placed on \_\_\_\_\_ vide Receipt No. \_\_\_\_\_ by Shri/M/s. \_\_\_\_\_ in connection with the work of \_\_\_\_\_

\_\_\_\_\_ as the tender of the above party has been accepted / had not been accepted and the concerned contractor has paid security deposit of Rs. \_\_\_\_\_ for the above referred work on Dt. \_\_\_\_\_. The party has also executed an agreement for the above work. The above deposit stands in full in the name of the said party as certified by the Accountant on \_\_\_\_\_. The expenditure will be debited on B.H.G. Tender Deposit Account.

Assistant Engineer / Jr. Engineer.

Dy. Engineer,

Sanctioned Accordingly.

EXECUTIVE ENGINEER,  
BHAVNAGAR MUNICIPAL CORPORATION,  
BHAVNAGAR.



## 18.0 FORM OF BID SECURITY (BANK GUARANTEE)

WHEREAS, \_\_\_\_\_ [*Name of Bidder*] (hereinafter called "the Bidder") has submitted his biddated \_\_\_\_\_ [*Date*] for the construction of \_\_\_\_\_ [*Name of Contract*] (hereinafter called "the Bid").

KNOW ALL MEN by these presents that We \_\_\_\_\_ [*Name of Bank*] of \_\_\_\_\_ [*Name of Country*] having our registered office at \_\_\_\_\_ (hereinafter called "the Bank) are bound as principal obligator unto \_\_\_\_\_ [*Name of Employer*] (hereinafter called "the Employer") and unconditionally and irrevocably guarantee the payment to the sum of \_\_\_\_\_ for which payment well and. truly to be made to the said Employer the Bank binds himself, his successors and assigns by these presents.

SEALED with the Common Seal of the said Bank this \_\_\_\_\_ day of \_\_\_\_\_ 20\_\_\_\_\_ .

### THE CONDITIONS of this obligation are:

- (1) If the bidder withdraws his Bid during the period of bid validity specified in the Form of Bid:  
or
- (2) If the Bidder refuses to accept the correction of errors in his Bid;  
or
- (3) if the Bidder, having been notified of the acceptance of his Bid by the Employer during the period of Bid validity;
  - (a) fails or refuses to execute the Form of Contract Agreement in accordance with the Instructions to Bidders, if required; or
  - (b) fails or refuses to furnish the Performance Security, in accordance with the Instructions to Bidders;

We undertake to pay to the Employer up to the above amount upon receipt of its first written demand, without the Employer having to substantiate its demand, provided that in its demand the Employer will note that the amount claimed by it is due to it owing to the occurrence of one or all of the three conditions, specifying the occurred condition or conditions.

This Guarantee will remain in force up to and including the date \_\_\_\_\_ days after the deadline for submission of bids as such deadline is stated in the Instructions to Bidders or as it may be extended by the Employer, notice of which extension(s) to the Bank is hereby waived. Any demand in respect of this Guarantee should reach the Bank not later than the above date.

DATE \_\_\_\_\_

SIGNATURE OF THE BANK \_\_\_\_\_

WITNESS \_\_\_\_\_

SEAL

\_\_\_\_\_

\_\_\_\_\_  
(Signature, Name, and Address)

## 19.0 FORM OF CONTRACT AGREEMENT

### AGREEMENT

THIS AGREEMENT made the \_\_\_\_\_ day of \_\_\_\_\_ 20\_\_\_\_\_ between

\_\_\_\_\_ of \_\_\_\_\_ (hereinafter called "the Employer") of the one part and \_\_\_\_\_ of \_\_\_\_\_ (hereinafter called "the Contractor" of the other part.

WHEREAS the Employer is desirous that certain Works should be executed by the Contractor, viz.,

\_\_\_\_\_ and has accepted a Bid by the Contractor for the execution and completion of such Works and the remedying of any defects therein at a cost of Rs. \_\_\_\_\_ and \_\_\_\_\_.

NOW THIS AGREEMENT WITNESSETH as follows:

In this Agreement, words and expressions shall have the same meanings as are respectively assigned to them in the Conditions of Contract hereinafter referred to.

The following documents shall be deemed to form and be read and construed as part of this Agreement, viz:

- a) The Contract Agreement;
- b) The Letter of Acceptance;
- c) The Employer's Requirements;
- d) The Bid;
- e) The Conditions of Contract - G.C. etc.
- f) The Conditions of Contract - I.T. etc.
- g) Special Conditions of Contract
- h) The Specifications;
- i) The Bid Drawings;
- j) The Schedules; and
- k) The Contractor's Proposal
- l) Standing Committee Resolution
- m) All amendment, Addendum, Errata
- n) Minutes of Pre-bid meeting

In consideration of the payments to be made by the Employer to the Contractor as hereinafter mentioned, the Contractor hereby covenants with the Employer to execute and complete the Works and remedy any defects therein in conformity in all respects with the provisions of the Contract.

The Employer hereby covenants to pay the Contractor in consideration of the execution and completion of the Work and the remedying of defects therein the Contract Price or such other sum as may become payable under the provisions of the Contract at the times and in the manner prescribed by the Contract.

IN WITNESS whereof the parties hereto have caused this Agreement to be executed the day and year first before written.

The Common Seal of \_\_\_\_\_ was hereunto

affixed in the presence of:

\_\_\_\_\_ or \_\_\_\_\_

Signed, sealed, and delivered by the said \_\_\_\_\_  
in the presence of: \_\_\_\_\_  
Binding Signature of Employer \_\_\_\_\_

**Binding Signature of Contractor** \_\_\_\_\_

## 20.0 FORM OF PERFORMANCE SECURITY (BANK GUARANTEE)

To: \_\_\_\_\_ (name of Employer)

\_\_\_\_\_ (address of Employer)

WHEREAS \_\_\_\_\_ (name and address of Contractor) (hereinafter called "the Contractor") has undertaken, in pursuance of Contract No. \_\_\_\_\_ dated \_\_\_\_\_ to execute \_\_\_\_\_ (name of Contract and brief description of Works) (hereinafter called "the Contract");

AND WHEREAS it has been stipulated by you in the said Contract that the Contractor shall furnish you with a Bank Guarantee by a recognized bank for the sum specified therein as security for compliance with his obligations in accordance with the Contract;

AND WHEREAS we have agreed to give the Contractor such as Bank Guarantee;

NOW THEREFORE we hereby affirm that we are the Guarantor and responsible to you as principal obligator, on behalf of the Contractor, un conditionally and irrevocably guarantee the payment of an amount to total of \_\_\_\_\_ (amount of Guarantee) \_\_\_\_\_ (amount in words), such sum being payable in the types and proportions- of currencies in which the Contract Price is payable, and we undertake to pay you, upon your first written demand and without cavil or argument, any sum or sums within the limits of \_\_\_\_\_ (amount of Guarantee) as aforesaid without your needing to prove or to show grounds or reasons for your demand for the sum specified therein.

We hereby waive the necessity of your demanding the said debt from the Contractor before presenting us with the demand.

We further agree that no change or addition to or other modification of the terms of the Contract or of the Works to be performed thereunder or of any of the Contract documents which may be made between you and the Contractor shall in any way release us from any liability under this guarantee, and we hereby waive notice of any such change, addition or modification.

This guarantee shall be valid until the date of issue of the performance certificate.

### SIGNATURE AND SEAL OF THE GUARANTOR

Name of Bank \_\_\_\_\_

Address \_\_\_\_\_

Date \_\_\_\_\_

## 21.0 VENDOR LIST

**MUNICIPAL CORPORATION**  
**BHAVNAGAR**

Sr. No.	Item	Recommended/Suggested Brands
1.	Cement	Ambuja, Hathi, Ultra Tech, Sanghi, Siddhi, Hi-bond Kamal - O.P.C. 53 grade
2	White Cement	J.K. White, Birla White, Nihon White
3.	Steel	TMT Bars Fe-500D conforming to IS-1786:1985 (reaffirmed 2004) TISCO, SAIL, VIZAG, Kamdhenu, NATIONAL, Electrotherm, JSW, Welspun steel, Pollad Steel, DIAMOUND TMT, M. G. Steel, Friends Steel, Crown next TMT, Briskon TMT, GERMAN TMX
4	Structural Steel	SAIL, TISCO, IISCO, Vizag, Asian
5.	(A) Vitrified tiles for EWS-1 Soluble Salt Type (B) Vitrified tiles for EWS-2 Double charged Type	Asian, Kajaria, Jonson, Varmora, Simpolo, OASIS
6	Ceramic tiles	Asian, Kajaria, Jonson, Varmora, Simpolo, OASIS
7	100 % Vitrified Parking tiles	Asian, Kajaria, Jonson, Varmora, Simpolo, OASIS
8	Glazed tiles	Asian, Kajaria, Johnson, Varmora, Simpolo
9	Wash basin	Cera, Hindware, Parryware
10.	(A) PVC water supply pipes (SCH-80)	Finolex, Supreme, Jain, Kisan, Astral, Dutron, Prince
	(B) PVC pipe (SCH-40) as rainwater spout	Finolex, Supreme, Jain, Kisan, Astral, Dutron, Prince
11	M.S. Tubes	TATA, Zenith, Asian, Jindal, Dutron
12.	(A) PVC Drainage lines pipes (U-PVC pipe (SWR) confirming to IS no. 13592 (Type "B"))	Finolex, Supreme, Jain, Kisan, Astral, Dutron, Prince
	(B) PVC Rainwater pipes (U-PVC pipe (SWR) confirming to IS no. 13592 (Type "A"))	Finolex, Supreme, Jain, Kisan, Astral, Dutron, Prince
13.	P.V.C. pipes (6 Kg f/cm <sup>2</sup> )	Finolex, Supreme, Jain, Kisan, Astral, Dutron, Prince
14.	Aluminium sections	Jindal, Hindalco, Banko, Ajin India, Aldowin, Alumilite
15	All Aluminium Hardware, Fittings	Rajdoot, Belu, Diamond, Glider, Ajin India, Aldowin, Alumilite

16	Glass/Float	Saint Gobain, Modi, Hindustan ,Tata , Asahi, Triveni, Shree Vallabh
17.	Kitchen sinks	Nirali, Diamond,Cobra, Jayna
18.	C.P brass screw down Bib tap / pillar cock / stop cock conform to I.S. 781-1977- (Wt. 400 gm.)	Crown, Prince, Jaguar-ESSCO, Cera, Hindware or equivalent as approved by EIC.
19.	Electric Items	
	(i) Wires	KEI, POLYCAB, AEROLEX, ALLWIN, FINOLEX, L & T , ULTRA CAB
	(ii) Switches and Accessories	Anchor, Alex, L&T, NorthWest, Great White, GM, Haier
	(iii) Cable	KEI, POLYCAB, AEROLEX, ALLWIN, FINOLEX, L & T , ULTRA CAB
	(iv) ARMOURED CABLES	KEI, POLYCAB, AEROLEX, ALLWIN, FINOLEX, L & T , ULTRA CAB
	(v) MCB/ELCB/RCCB/ Distribution Board/Change over switch/SFU/SDF/ Motor Starter	Siemens/ L&T (Exora)/Hager/Havells/ABB/Legrand
	(vi) Pump Set	Kirlosker, Crompton, JASCO, MATHER & PLATT
	(vii) Luminaries	Philips, GE
	(viii) RIGID pipes & Accessories-for concealed wiring	Finolex,Precision,Polycab, SHAKTI
	(ix) Liquid Level Controller	GELCO, OCLEG, ELICO
	(x) Earthing /Lightning Arrestor	E-Link, Ashlok, Rip, Etp
(xi) LED Aviation Light	Alpha-Lite, AvidsTechnovators Pvt Ltd. or equivalent as approved by EIC	
20.	GI Pipes/Fittings	Jindal / Tata/Asian
21.	Door shutters	As per approval of Engg-in-charge and shall be fitted after testing and approval.
22	(A)Flush Doors (confirming to I.S.1003 Part-I 1991)	'Sitapur plywood', 'Mysoboard', Sudarshan W &P Industries, Bajwa, Baroda, Goyal, industrial corp, Wood craft, Jain wood industries, Alpro, Genda-Northen Doors, Greenply, Kitply, Bhutan or equivalent as approved by EIC
	(B)PVC Doors(PVC material confirming to IS 10151-1982)	Syntex
23.	Door Frames	
	Teak Wood	Bulsar/ C.P Teak (Second Class specified)
	Sal Wood	Sal wood [Indian or Imported] First class
24.	Door Fittings / Hinges	Godrej, Efficient Gadgets (E.G.) Dunex, Doorset, Suzu, Coral & Suzu, Yama, E.P.P.W.

25	Plywood Products Commercial Block Board Commercial Ply Teak Ply	Greenply, Kitply / Century, Anchor, Duro, Green Ply, Western India plywood(WIP), Mysore marine
26	Laminates / Decorative laminates	Decolam, GreenlamMerinolam Formica, National laminate, Decolite, Delta
27	Pre laminated board	Bhutan, Eco board, Bakelite HylemNepalboard, Green board
28	Impregnated Fibre Board	Shalitex by Shalimar Tar Product
29.	Exterior colour (weather shield max)	ICI, Asian, Nerolac, Burge
30	Synthetic Enamel Paints /Oil bound distemper satin finish	ICI, Asian, Nerolac, Burge
31	Putty	J.K. white, Birla white
32.	Paver Blocks	Regency, Gurjari, Vyara, PEEDEE, Jagruti – Surator as approved by EIC/consultant
33.	D.G. Sets	Engine: Cummins, Greaves, Kirloskar, Ashok layland Alternator: Crompton, KEC, Stamphord
34.	AAC Block(confirming to IS : 2185, Part III)	Aerocon, Magicrete, Biltech, Litecone, Ecolite, Xtralite, NXTBLOC make [autoclaved aerated block] or as approved by EIC.
35	Chemical mortar/AAC block jointer	lolite cube bond, Fairmate, Lion joint mortar, MAP block set, NXTFIX Block and equivalent ISI brand
36.	Water Proofing Compound	Zycosil, Dr. Fixit,Kerakoll, Pidilite, Roff
37.	Polycarbonate Sheets	Lexan, GE or approve by Engineer – in -Charge
38.	Construction Chemicals	Fosroc, MC-Bauchmie, Sika, Pidilite, Roff,Perma
39.	Drainage line network	NP 3 class of BHAGIRATH CEMENT PRODUCT, (HIMALAYA & HERO), SONI CEMENT PRODUCT , VIPUL SPUN PIPES, KATARIYA& CO., OMKARESHVAR PIPES, OMKAR PIPES, MARUTI PIPES, KALATHIYA PIPES , R. S. PIPES, UMA HUME PIPES, SIDHDHIVINAYAK , S.K. Corporation, Laxmi Price Industries, S.J. Corporation or as approved by EIC
40.	Water supply network	G.I. Pipes, UPVC pipes
41	Anti-Termite Treatment	Thyodin by Hoechest, Lyntric by Bayer India, Durmet by Cynamid India, Nocil Pyramid
42	FRP Sheets	Angel Industries, Cooltech System, Fiber Tech composite Pvt. Ltd. or approve by Engineer – in -Charge
43	Polyester Fibre	Recron 3S or approve by Engineer – in -Charge.
44	Welding Rod	Advani, Philips, Sunarc, Eshab



45	Cast Iron Pipes and Fittings(LA Class)	NECO, Swayarhoo, Bengal, Oriental Castings, Electro steel Castings
46	R.C.C. Pipes conform to I.S. 458-1971	Indian Hume Pipe Co., Alcock Cement Products, Patel Spun (Surat)
47	G.I. Pipes conform to I.S. 1239-1968	Jindal, Tata, Bharat Steel Tube, Bombay, Zenith, G.S.T.Unik. ("C" Class)
48	G.I. Fittings	"R" Mark, Unik.
49	Gun Metal Valves (Heavy)	Leader Engineering Works, Jalandhar, Crown / prince – Surat Bombay Metal Co Annapurna Metal Work, Calcutta 'Sant' brand, Jalandhar, L&K, Bombay metal & Alloy man. co. Bomaby, Premier, Aatco, Atlas, BR, BS, NN.
50	Brass fittings (Heavy)	Leader Engineering Works, Calcutta L & K Mathura, Crown / Prince - Surat Annapurna Metal Works, Calcutta, Perko, Kingstone Ark, Enclss Willians, Chilly, Aquva Plus, Nova, Kingstone, Driple, Ranutrol Hansa.
51	C.P. Fittings (Heavy)	Ego Metal Works, Ballabgarh, GEM, New Delhi; Soma Calcutta; Bilmet, Bombay 'ESSCO', Delhi. Rajka Metal Works, Delhi Eng. Co. Metal Works, Calcutta Everite, NU-Lite Navbhart Shalimar Crown, Prince
52	W.C. Pan / Washbasin / Urinals /Anglow Indian W.C. Pan	Cera, Hindware, Parryware
53	Stainless Steel Sinks	Nirali, Diamond, Cobra
54	Mirrors	Atul Glass Works , Haryana Sheet Glass Vallabh Glass Works, Modi Float glass, Asahi, Saint Gobin
55	Plumbing /Sanitary Fixtures /Accessories	Jaquar continental , CERA, Hindustan Sanitaryware / Parryco India. Hindware, Lauvet, Kohlar, Rak, Jaquar
56	C.I. Sluice valve, Check valves	Kirloskar, DURGA, L & T Valves, Jupiter, SACHDEVA
57	UPVC Borewell Column pipe	Finolex, Supreme, Jain, Kisan, Astral, Dutron, Prince
58	Fibre reinforced R.C.C. Manhole Cover	Pratibha, CIDCO, approved brand by BMC
59	C.I. Manhole cover with frame	Manish, Sil, NECO
60	P.V.C. Pipes & Fittings	Finolex, Supreme, Jain, Kisan, Astral, Dutron, Prince
61	P.V.C. / H.D.P.E Water Tanks	SIntex, Aqua
62	Ball Cock	GPA Brand by Govardhan Das Jullunder, L & K Brand by L. K.Industries Mathura, Orbit Engineers, Sant Brand by Sant Press Metal Works Jullundhar
63	UPVC Pipes (Solvent Welded Joints)	Astral, Supreme, Prince, Jain
64	C.P.V.C. Pipes & Fittings	Finolex, Supreme, Jain, Kisan, Astral, Dutron, Prince

65	Water meter	Kapstan Bombay, Voltas Kent, Calcutta or equivalent as approved by BMC
66	SWR pipe	Astral, Supreme, Prince, Finolex
67	Air Valve, Scour Valve	Kirloskar Brothers Limited (KBL), FOURESS Engineering (India) Limited., Durga Valves Pvt.Ltd, Orbinox, shree kishna industries
68	P.V.C. non-return full way wheel valve	Prince/Supreme/Jain/Astral
69	C.P. brass half turn flush cock	crown, prince, Jaguar, Plumber, Hindware or equivalent
70	Water cooler	Voltas, Godrej, blue star, carrier, Electrolux
71	HDPE pipe	Astral, Dutron, Duraline, Narmada, RIL (PIL), Penwalt, Anjney, jain irrigation, Sangir
72	Submersible pump	Kirloskar, KSB, JASCO, Crompton Greaves, La Gajjar, Pullen Pumps, MBH
73	Sluice Valve	Kirloskar, Durga, L&T valve, Jupiter, sachdeva
74	Exhaust fan	Crompton, Bajaj, Havells
75	Ceiling Fan	Crompton, Bajaj, Havells
76	Air Conditioner	Hitachi / Blue star / LG / Voltas / General / Carrier / Mitsubishi
77	Welding & welding rod	MIG welding & ESAB / ADOR / L&T
78	Furniture	Godrej or approve by Engineer – in -Charge.
79	Self-Supporting Roof	Proflex, Green Curve, Kailash roofing or approve by Engineer – in - Charge.
80	Turbo air Ventilator	Proflex, Cooltech System or approve by Engineer – in -Charge.

**Notes:**

The following guidelines are to be noted with regard to use of materials in the work:

- a)** The contractor shall produce samples of the materials for approval of the EIC. The materials of the makes, out of the above as approved by the EIC shall be used on the work.
- b)** In respect of materials for which approved makes are not specified above, the make/brand will be decided by the EIC.
- c)** Before bulk purchase of quantities of materials, it is the responsibility of the Contractor to get the samples of materials approved from consultant and EIC.
- d)** All cost towards the testing shall be borne by the contractor.
- e)** For all the material of approved brands necessary testing as per IS standards shall be done by the agency and no extra payment shall be paid for that.

**BHAVNAGAR MUNICIPAL CORPORATION**  
**E-Tender Notice SHORT TERM**

**E-Tender Notice No. 15 BMC/DRAINAGE/AMRUT 2.0/tender/2024-25**



**Bid Documents For**  
**CONSTRUCTION OF STORE AREA FOR DRAINAGE DEPARTMENT, BMC AT**  
**F.P. NO. 66 UNDER T.P. SCHEME NO. 7 ADHEWADA, BHAVNAGAR**

**VOLUME –II**  
**PRICE BID**

<b>Milestone Dates</b>	
Date of issue of placing tender document start date	As per tender volume I
Last date of Online Tender Submission	As per tender volume I
Last date of submission of physical Documents	As per tender volume I
Online Opening date of the Technical Bid (If convenient.)	As per tender volume I

**CLIENT:**  
**Executive Engineer (Drainage Department),**  
**Bhavnagar Municipal Corporation.,**  
**Sir Mangalsinhji Road,**  
**Bhavnagar- 364 001**

## 1.0 FORM OF PRICE PROPOSAL

**Bidders are required to fill up all blank spaces in this Bid Form**

To DEPUTY COMMISSIONER (ADMIN),  
Bhavnagar Municipal Corporation,  
Mangal Sinhji Road,  
Bhavnagar – 364 001.  
(Gujarat) – INDIA.

**SUB : CONSTRUCTION OF STORE AREA FOR DRAINAGE DEPARTMENT, BMC  
AT F.P. NO. 66 UNDER T.P. SCHEME NO. 7 ADHEWADA, BHAVNAGAR**

We have examined the Conditions of Contract, Employer's Requirements, Schedules, Addenda's and the matters set out in the Appendix hereto. We have understood and checked these documents and have not found any errors in them. We accordingly offer to design, execute commission and to maintain for the three years the said Works and remedy any defects, fit for purpose in conformity with these documents and the enclosed Proposal, **I am agree to complete work within given time limit with \_\_\_\_\_% above or below (strikeout which is not applicable)** and other such sums as may be determined in accordance with the terms and conditions of the Contract. The above amounts are in accordance with the Price Schedules herewith and are made part of this bid.

We confirm our agreement with the appointment of Dispute Adjudication Board of General Condition of Contract.

We agree to abide by this Bid until **180 days** and it shall remain binding upon us and maybe accepted at any time before that date. We acknowledge that the Appendix forms part of our Bid.

If our bid is accepted, we will provide the specified performance security, commence the Works as soon as reasonably possible after receiving the Employer's Representative's notice to commence, and complete the Works in accordance with the above-named documents within the time stated in the Appendix to Technical Proposal.

Unless and until a formal Agreement is prepared and executed, this Bid, together with your written, acceptance thereof, shall constitute a binding contract between us.

We understand that you are not bound to accept the lowest or any bid you may receive.

We are, Gentlemen

Yours faithfully

Signature \_\_\_\_\_ in the capacity of \_\_\_\_\_ duly authorized to sign  
bids for and on behalf of

\_\_\_\_\_

Address

\_\_\_\_\_

\_\_\_\_\_

Date \_\_\_\_\_

# **APPENDIX TO PRICE PROPOSAL**

**2.0 APPENDIX TO PRICE PROPOSAL****Conditions of Contract**

Employer's name and address	City Engineer , Bhavnagar Municipal Corporation, Mangal Sinhji Road, Bhavnagar – 364 001. (Gujarat ) – INDIA.
Contractor's name and address	_____ _____ _____ _____
Phone No. :	
Fax No. :	
E-mail :	
Time for notice to commence	<b>7 Days</b>
Name and address of the Employer's Representative/Engineer	To be nominated by Employer at the time of Award of Contract
Time for Completion of construction of Works	As mentioned in Vol I
Validity Period of Tender Offered	<b>180 days from the last date of receiving of the Tender.</b>
Defects liability period	<b>24 months after commissioning</b>
Period for O & M Contract	N A
Language for communications	English
Electronic transmission systems	
Confidential Details	_____ _____

		_____
		_____
		_____
Currency of all payments	Indian Rupees	
Amount of insurance for work	Total cost of work	
Amount of third party insurance	As per law per occurrence, number of occurrences: maximum three	
Periods of insurance	Up to contract period till completion of WORK	
Evidence of insurance	30 days from commencement date	
Relevant policies	60 days -do-	
Number of members of Arbitral Tribunal	As per the Arbitration and Conciliation Act 1996, India along with its latest amendments.	}
Members of Dispute Adjudication Board (if not agreed) to be nominated by		
Arbitration rules		
Language of arbitration	English	
Place of arbitration	Bhavnagar, Gujarat, India	
Procedural Law	Indian as governed by the Arbitration and Conciliation Act, 1996, India and its latest amendments.	
Limit of Retention Money	As mentioned in Vol I	
Payments in Local Currencies	In Indian Rupees	
Time for access to the Site	Within 15 days from the date of Letter of Work Order Acceptance / Letter of Intent/ Handing over of clear site will prevail.	



Amount of performance security	As mentioned in Vol I
Damages for delay	0.1 % per day with limit as 10% of the Construction Contract Price or as decided by Hon. Commissioner, BMC
Deductions of Labor Cess	: 1 % of contract price for construction workers welfare fund from all R.A. Bills & final Bill.
Deductions of GST	: GST as per prevailing Government Rules, will be paid extra in all R.A. Bills & final Bill.
Deductions of Income Tax	: <b>2%</b> and additional cess if applicable , as applicable of contract price from all R.A. Bills & final Bill.

**BHAVNAGAR MUNICIPAL CORPORATION  
DRAINAGE DEPARTMENT**

**NAME OF WORK : CONSTRUCTION OF STORE AREA FOR DRAINAGE DEPARTMENT, BMC AT F.P. NO. 66  
UNDER T.P. SCHEME NO. 7 ADHEWADA, BHAVNAGAR**

**3.0 PRICE SCHEDULE - B: (SCHEDULE OF PRICES)**

Sr. No.	Description	Unit	Quantity	Rate	Rate in Words	Amount (Rs.)
1	Boring holes 3.5 m deep in ordinary soil (for cast in situ piles) and getting out the soil and disposal of the surplus excavated soil as directed within a lead of 50 Meter for following diameter of pipes.(ii) 250 mm	Each	126.00	1270.11	Rupees One Thousand Two Hundred Seventy and Eleven Paise	1,60,033.86
2	Extra for under reaming inside the bore Holes for under reamed piles of following Diameter.(ii) 250 mm	Each	126.00	508.74	Rupees Five Hundred Eight and Seventy Four Paise	64,101.24
3	Excavation for foundation including sorting out and stacking of useful materials and disposing off the excavated stuff upto 50 Meter lead.(B) Dense or Hard soil (A) Up to 1.50 Mt. Depth	Cu.m	3415.66	149.67	Rupees One Hundred Forty Nine and Sixty Seven Paise	5,11,221.83
4	(B) From 1.50 Mt to 3.00 Mt. Depth	Cu.m	697.05	162.38	Rupees One Hundred Sixty Two and Thirty Eight Paise	1,13,186.98

Sr. No.	Description	Unit	Quantity	Rate	Rate in Words	Amount (Rs.)
5	Excavation for pipe line trenches for water supply, sewerage line, manhole etc. all with shoring and strutting if required as per required gradient and line including safety provisions using site rails and stacking excavated stuff including up to all required lead cleaning the site etc. complete for all lifts and strata as specified.etc. Completed as per director. 0.00 to 1.50 mt depth b) in hard murrum, boulders incl. macadam road.	Cu.m	350.00	155.25	Rupees One Hundred Fifty Five and Twenty Five Paise	54,337.50
6	1.5 to 3.0 mt depth b) in hard murrum, boulders incl. macadam road.	Cu.m	9.00	170.2	Rupees One Hundred Seventy and Twenty Paise	1,531.80
7	Dewatering In all sorts of soil and soft murrum, hard Murrum and boulders, Soft Rock, Hard Rock, beyond 1.5 mt. depth from G. L. 1.5 to 3.0 mt depth	Cu.m	9.00	31.05	Rupees Thirty One and Five Paise	279.45
8	Providing bedding incl. ramming, watering, levelling, consolidating etc. Complete as per standard and instruction of engineer incharge. As above with required quality Sand brought from outside including all lead	Cu.m	7.00	378.35	Rupees Three Hundred Seventy Eight and Thirty Five Paise	2,648.45
9	Earthwork for embankment including breaking clods, dressing with all lead and lift and including watering rolling and consolidation of subgrade in layers at O.M.C. to required dry density including filling the depression which occur during the process using power	Cu.m	10791.00	169.44	Rupees One Hundred Sixty Nine and Forty Four Paise	18,28,427.04

Sr. No.	Description	Unit	Quantity	Rate	Rate in Words	Amount (Rs.)
	roller 8T to 10T.(E) From Borrow area within 3.0KM. lead					
10	Providing, laying and spreading of compacted thickness of 200mm Hard Murrum and binding material to compact to the required density with 8 - 10 tonne vibratory roller , maintaining the required slope & grade during the operation as approved by the engineer in charge & watering to the proper moisture content and sprinkled with the help of truck mounted water tank fitted with suitable arrangement etc completed as per specification .	Cu.m	726.00	750.43	Rupees Seven Hundred Fifty and Forty Three Paise	5,44,812.18
11	Providing & laying of 150mm compacted thickness Granular sub base (GSB) in grading V in table 400-1 of the specification MORT&H fifth revision and compactor to the required density with 8 - 10 tonne vibratory roller with plain drum or heavy pneumatic tyred roller of minimum 200 to 300 KN weight in all seasons as per MORT&H , maintaining the required slope & grade during the operation as approved by the engineer in charge & watering to the proper moisture content and sprinkled with the help of truck mounted water tank fitted with suitable arrangement .( fully saturated having CBR value greater or equal to 30)	Cu.m	238.00	1221.09	Rupees One Thousand Two Hundred Twenty One and Nine Paise	2,90,619.42
12	Filling in foundation and plinth with murrum or selected soil in layers of 20cm. thickness including watering, ramming and consolidating etc.	Cu.m	58.00	289.06	Rupees Two Hundred Eighty	16,765.48

Sr. No.	Description	Unit	Quantity	Rate	Rate in Words	Amount (Rs.)
	complete.				Nine and Six Paise	
13	Refilling of Pipeline trenches Refiling of the pipeline trenches/ foundation incl. ramming, watering , consolidating desposal of surplus stuff as directed within state limit as directed	Cu.m .	229.00	25.3	Rupees Twenty Five and Thirty Paise	5,793.70
14	Providing and filling sand and Lime mixture below R.C.C. Raft in Layers including ramming and watering complete.	Cu.m .	29.00	565.25	Rupees Five Hundred Sixty Five and Twenty Five Paise	16,392.25
15	Providing and laying cement concrete 1:3:6 (1-Cement : 3- coarse sand : 6- hand broken stone aggregates 40 mm nominal size) and curing complete excluding cost of formwork in (A) Foundation and Plinth	Cu.m .	398.57	3005.76	Rupees Three Thousand Five and Seventy Six Paise	11,98,017.79
16	Providing & laying controlled cement concrete M200 and curing complete including the cost of formwork but excluding the cost of reinforcement for reinforced concrete work in (A) Foundation, footing, base of columns and Mass concrete.	Cu.m .	22.00	4605.6	Rupees Four Thousand Six Hundred Five and Sixty Paise	1,01,323.20
17	Providing & laying controlled cement concrete M200 and curing complete including the cost of formwork but excluding the cost of reinforcement for reinforced concrete work in Column, Beam, Coping Etc.	Cu.m .	56.00	7219.5	Rupees Seven Thousand Two Hundred Nineteen and Fifty Paise	4,04,292.00

Sr. No.	Description	Unit	Quantity	Rate	Rate in Words	Amount (Rs.)
18	Providing & laying controlled cement concrete M250 and curing complete including the cost of formwork but excluding the cost of reinforcement for reinforced concrete work : (A) For Foundation, Footing, Base of columns and Mass concrete.	Cu.m	584.00	4868.36	Rupees Four Thousand Eight Hundred Sixty Eight and Thirty Six Paise	28,43,122.24
19	(B) columns, pillars posts and struts, up to floor two level.	Cu.m	84.39	7255.57	Rupees Seven Thousand Two Hundred Fifty Five and Fifty Seven Paise	6,12,297.55
20	(C)Slabs,landing,shelves,Balconies, Lintels, Beams, Girders and Cantilever upto floor two level.	Cu.m	115.65	8106.82	Rupees Eight Thousand One Hundred Six and Eighty Two Paise	9,37,553.73
21	Providing TMT bar FE-500D reinforcement work including bending, binding & placing in position complete up to floor two level.	Cu.m	65125.50	76.21	Rupees Seventy Six and Twenty One Paise	49,63,214.36
22	Providing and fixing remoulded compressible filler board in black colour conforming to MoRT&H Specifications (Clause 1015), having minimum density 95Kg./Cu.m. non-staining with less than 1% water absorption & compression recovery of 93% minimum as per specification for 20 mm wide expansion joint including cutting to required size	Rmt.	72.00	796.67	Rupees Seven Hundred Ninety Six and Sixty Seven Paise	57,360.24

Sr. No.	Description	Unit	Quantity	Rate	Rate in Words	Amount (Rs.)
	and shape at all levels etc.complete as directed.					
23	Providing and fixing pre-cast Rubber Dye / steel Dye inter locking concrete block 60mm thick with grade of concrete M300 pneumatic compressed / vibrated mechanically and as per approved design Confirming to IS 15658 : 2006 including 35 mm Sand layer for levelling and filling the joint with sand in proper line and level as per guidelines of IRC : SP 63-2018 etc. Complete.	Sq.m	1377.00	686.9	Rupees Six Hundred Eighty Six and Ninety Paise	9,45,861.30
24	A Pick and Carry Hydraulic Mobile Crane (Old Generation Hydra Crane with Rear Mounted Cabin) is a heavy-duty lifting machine with a hydraulic telescopic boom mounted on articulated chassis, powered by hydraulic systems for precise lifting and positioning of heavy loads in construction, agriculture, mining, forest, industry and others.	Nos.	1.00	2060000	Rupees Twenty Lac Sixty Thousand Only	20,60,000.00
25	Brick work using common burnt clay building bricks having crushing strength not less than 35 Kg./Sq.Cm. in Cement Mortar 1:6 (1- Cement : 6 -fine sand)(B) Conventional (A) In Foundation and Plinth	Cu.m	1.00	4021.02	Rupees Four Thousand Twenty One and Two Paise	4,021.02
26	(B) In Superstructure above plinth level up to floor two level	Cu.m	191.00	4289.33	Rupees Four Thousand Two Hundred Eighty Nine and	8,19,262.03

Sr. No.	Description	Unit	Quantity	Rate	Rate in Words	Amount (Rs.)
					Thirty Three Paise	
27	Filling available excavated earth (excluding rock) in trenches. plinth, sides of foundations etc. in layers not exceeding 20 cm. in depth consolidating each deposited layer by ramming and watering.	Cu.m	1455.34	130.39	Rupees One Hundred Thirty and Thirty Nine Paise	1,89,761.13
28	Cement Plaster (20 mm thick) A) Cement plaster 20 mm thick in C.M. 1:2 using water proofing compound of approved quality including finishing etc. complete.	Sq. m.	47.30	232.3	Rupees Two Hundred Thirty Two and Thirty Paise	10,987.79
29	Providing 10mm thick cement plaster in single coat on brick/concrete walls for interior plastering upto floor two level and finished even and smooth in (i)Cement mortar 1:3 (1-cement:3-sand)	Sq.m	461.00	138.71	Rupees One Hundred Thirty Eight and Seventy One Paise	63,945.31
30	Providing 15mm thick cement plaster in single coat on Rough (Similar)side of single or half brick walls for interior plastering upto floor two level and finished even and smooth in (i) Cement mortar 1:3 (1-cement:3-sand)	Sq.m	160.00	186.12	Rupees One Hundred Eighty Six and Twelve Paise	29,779.20
31	20mm thick sand faced cement plaster on walls upto height 10 metres above ground level consisting of 12mm thick backing coat of C.M. 1:3 (1-cement : 3-sand) and 8mm thick finishing coat of C.M. 1:1 (1-cement : 1-sand) etc. complete.	Sq.m	2035.00	326.11	Rupees Three Hundred Twenty Six and Eleven Paise	6,63,633.85



Sr. No.	Description	Unit	Quantity	Rate	Rate in Words	Amount (Rs.)
32	Finishing wall with water proofing cement paint of on wall surfaces (Three coats) to give an approved brand and manufacture and of required shape even shade after thoroughly brushing the surface to remove all dirt and remains of loose powered materials.	Sq.m .	2037.00	88.94	Rupees Eighty Eight and Ninety Four Paise	1,81,170.78
33	Wall painting (two coats) with plastic emulsion paint of approved brand and manufacture on under corated wall surface to give an even shade including thoroughly brushing the surface free from mortar droppings and other foreign matter and sand papered smooth.	Sq.m .	535.00	78.9	Rupees Seventy Eight and Ninety Paise	42,211.50
34	Providing and applying Epoxy paint of approved make to concrete surface for RCC ESR of GSR or any other structure including cleaning the surface by scrapping and air blowers to the satisfaction of Engineer-in-charge necessary scaffolding etc. complete with all leads and lifts and giving satisfactory hydraulic test for water tightness as per IS codes.	Sq.m .	24.06	90.9	Rupees Ninety and Ninety Paise	2,187.05
35	Constructing a cooking platform 60 cm. width and 70 cm high resting on B.B.Masonry walls 23 cm.thick in C.M.(1:6) with (ii) Fixing black kadappa stone 30mm thick laid on precast R.C.C. (1:2:4) slab with plastering on exposed faces of wall in C.M. (1:4) etc complete.	Rmt.	2.00	2656.06	Rupees Two Thousand Six Hundred Fifty Six and Six Paise	5,312.12
36	Providing and laying polished Kota stone slab flooring over 20mm (Average) thick base of cement mortar 1:6 (1-cement : 6-coarse sand) or L.M. 1.1.5 (1-Lime putty :1.5 - coarse sand) laid over and jointed with grey cement	Sq.m .	12.32	971.95	Rupees Nine Hundred Seventy One and Ninety	11,974.42

Sr. No.	Description	Unit	Quantity	Rate	Rate in Words	Amount (Rs.)
	slurry mixed with pigment to match the shade of slab including rubbing and polishing etc. complete. (A) 25mm thick				Five Paise	
37	Providing and laying polished Kota stone slab flooring over 20mm (Average) thick base of cement mortar 1:6 (1-cement : 6-coarse sand) or L.M. 1.1.5 laid over and jointed with grey cement slurry including rubbing and polishing etc. complete. (B) 30 mm thick	Sq.m	239.61	1038.76	Rupees One Thousand Thirty Eight and Seventy Six Paise	2,48,897.28
38	Providing and laying Ceramic tiles 6mm thick in flooring treads of steps and landing laid on a bed of 12mm thick cement mortar 1:3 (1-cement : 3-coarse sand ) finishing with flush pointing in white cement.	Sq.m	59.05	944.91	Rupees Nine Hundred Forty Four and Ninety One Paise	55,796.94
39	Providing and laying white glazed tiles 6mm thick in flooring treads of steps and landing laid on a bed of 12mm thick cement mortar 1:3 (1-cement : 3-coarse sand) finishing with flush pointing in white cement.	Sq.m	12.00	827.19	Rupees Eight Hundred Twenty Seven and Nineteen Paise	9,926.28
40	Providing and laying white glazed tiles 6mm thick in skirting risers of steps and dedo on 10mm thick cement plaster 1:3 (1 cement : 3-coarse sand) and jointed with white cement slurry	Sq.m	86.00	857.42	Rupees Eight Hundred Fifty Seven and Forty Two Paise	73,738.12
41	Providing and fixing flush door shutters, solid core construction with frame of first class hardwood with cross board and face veneer or plywood face panels, including anodised aluminium butt hinges with necessary screws. (B)	Sq.m	20.00	1797.77	Rupees One Thousand Seven Hundred Ninety	35,955.40

Sr. No.	Description	Unit	Quantity	Rate	Rate in Words	Amount (Rs.)
	Non-decorative type and block board core anodised aluminium butt hinges in flush door shutters (2) 35 mm thick.				Seven and Seventy Seven Paise	
42	Providing and fixing 35 mm thick shutters for Doors, windows and clerestory windows including Indian teak wood frames 10 cm x 7 cm. size including anodized aluminium fixtures and fastenings including primer coat of approved quality and two coats of oil painting etc, complete. (i) Fully Glazed.	Sq.m	11.00	4641.01	Rupees Four Thousand Six Hundred Forty One and One Paise	51,051.11
43	Steel work welded in built up sections framed work including cutting ,hoisting, fixing in position and applying a priming coat of red lead paint (A) In beams and joists, channels angles Tees, flats , with connecting plates or angle cleats as in main and cross beams. Hip and jack rafters, purlins connects to common rafters and the like.	quintal	351.00	9047.86	Rupees Nine Thousand Forty Seven and Eighty Six Paise	31,75,798.86
44	Providing and laying chequered terrazo tiles 28mm thick with marble chips of sizes upto 6mm in treads of stairs and staircases in 12mm thick bed of lime mortar 1:1.5 (1-Lime putty :1.5 coarse sand) or C.M. 1:6 (1- cement: 6- coarse sand) jointed with neat cement slurry mixed with pigment to match the shade of tiles including rubbing and polishing complete. (A) Light shades using white cement.	Sq.m	111.00	862.19	Rupees Eight Hundred Sixty Two and Nineteen Paise	95,703.09

Sr. No.	Description	Unit	Quantity	Rate	Rate in Words	Amount (Rs.)
45	Providing and fixing window having extruded aluminium Colour anodized section frame main outer size 95mm x 24mm x 1.17mm @ wt.of 0.738 Kg./mt , horizontal Three track member size 92mm x 31.75mm x 1.30mm,@ Wt.1.07 Kg./mt , vertical member of size 92mm x 31.75mm x 1.50mm @ Wt. 1.06 Kg./mt with sliding shutters of horizontal member size 40 mmx18mm x1.29mm @ wt.of 0.456 Kg./mt, vertical member of size 40mm x 18mm x 1.29 mm @ wt.of 0.456Kg./mt/ with 5 mm thick transparent bronze colour tinted float glass with powder coated aluminium fittings and fixtures and transparent silicon sealant glass fixing to frame as per details etc	Sq.m	17.00	1583.95	Rupees One Thousand Five Hundred Eighty Three and Ninety Five Paise	26,927.15
46	Providing and fixing M.S. grills of required pattern to wooden/Stone frames of windows etc. with M.S. flats at required spacings and frame around, square or round bars with round headed bolts and nuts or by screws (A) Plain Grill.	Kg.	406.99	101.17	Rupees One Hundred One and Seventeen Paise	41,175.18
47	Providing and fixing rolling shutters of approved make made of 80 mm wide M.S. laths inter-locked together through their entire length and jointed together at the ends by end locks mounted on specially designed pipe shaft with bracket plates, guide channels and arrangements for inside and outside locking with push-pull operation including the cost of hood cover and spring etc. complete. (B) Shutters having width 3.5 M. and above	Sq.m	20.80	4495.02	Rupees Four Thousand Four Hundred Ninety Five and Two Paise	93,496.42

Sr. No.	Description	Unit	Quantity	Rate	Rate in Words	Amount (Rs.)
48	Providing and fixing standared extruded of alluminium section of size 63mm x 38.10mm x 1.2mm @ Wt. 0.643 Kg./mt with colour anodized alluminium frame for ventilation with 5 mm thick frosted glass as details etc complete for Ventilation	Sq.m	12.00	1175.56	Rupees One Thousand One Hundred Seventy Five and Fifty Six Paise	14,106.72
49	Providing corrugated G.I. sheet of class-3 roofing fixed with glavanished iron J or L Hooks, Bolts and nuts 8mm diameter with bitumen and G.I. limpet washer or G.I. limpet washer. filled with white lead complete excluding the cost of purlins, Rafters and Trusses.(1) 0.80 mm thick sheet.	Sq.m	727.00	727.13	Rupees Seven Hundred Twenty Seven and Thirteen Paise	5,28,623.51
50	Providing and fixing 150mm wide 450mm over all semicircular plain G.I.sheet class-3 gutter with Iron brackets 40mm x 3mm size Bolts, Nuts, washers etc. including making necessary connection with rain water pipes. (i) 0.80 mm thick Sheet.	Sq.m	30.95	561.27	Rupees Five Hundred Sixty One and Twenty Seven Paise	17,371.31
51	Painting two coats (excluding priming coat) on new steel and other metal surface with enamel paint, brushing, interior to give an even shade including cleaning the surface an even shade including cleanicn the surface of all dirt, dust and other foreign matter.	Sq.m	563.00	87.81	Rupees Eighty Seven and Eighty One Paise	49,437.03

Sr. No.	Description	Unit	Quantity	Rate	Rate in Words	Amount (Rs.)
52	Providing & fixing UV stabilised fiberglass reinforced plastic sheet, including fixing with polymer coated 'J' or 'L' hooks, bolts & nuts 8mm dia. G.I plain/bitumen washers complete but excluding the cost of purlins, rafters, trusses etc. The sheets shall be manufactured out of 2400 TEX panel rovigs incorporating minimum 0.3% ultra-violet stabiliser in resin system under approximately 2400 psi and hot cured. They shall be of uniform pigmentation and thickness without air pockets and shall conform to IS 10192 and IS 12866. The sheets shall be opaque or translucent, clear or pigmented, textured or smooth as specified.	Sq.m	184.00	999.9	Rupees Nine Hundred Ninety Nine and Ninety Paise	1,83,981.60
53	Providing and fixing of Self Supported Structure Less PROFLEX or Equivalent Roofing systems with proper overlapping and seaming b/w different sheets without making holes or preventing the overturning the roof by wind addition made up from superior quality, structural grade steel. Base metal width 912 mm, Steel Grade : Grade D and Thickness 0.80 mm BMT, 0.85 mm APT with tolerance of +/- 0.04 mm, Regular Modified Polyester Imported Colour Coated Galvalume Steel having Profiled width of 625 mm +/-10mm. Design, supply, & fabrication of self supported single span arch roof fabricated from mechanically seamed manufactured by American Machines to profiles of Imported Galvalume Cold Rolled Structural Steel coils as per standard ASTM A792, Steel Sheet,	Sq.m	245.00	3265.306	Rupees Three Thousand Two Hundred Sixty Five and Thirty Paise	8,00,000.00

Sr. No.	Description	Unit	Quantity	Rate	Rate in Words	Amount (Rs.)
	Aluminium-Zinc Alloy Coated by Hot-Dip Process. The work should be carried out by specialize and approved agency only. The rate of item is including fitting as per standard specification.					
54	Providing and fixing of modules of 3 no of 24" dia Wind operated Aluminium Advanced type Turboventilators with single Transparent Skylight Sheet of 2ft width and 21ft length at interval of 10th panels in Self Supported Proflex Roofing Systems on centre as per manufacturers specifications	Nos.	3.00	15500	Rupees Fifteen Thousand Five Hundred Only	46,500.00
55	Providing and fixing full height Plan/colour PVC partition system 50mm thick consisting of 40mm sandwich PVC panel made out of 36mm high density expanded polystyrene sheet (E.P.S. Thermocol) stuck on both side with 2mm thick plain PVC sheet reinforced with frame work made from 35mm x 5mm M.S. angle. In between two M.S. angles 4 mm thick plan heat moulded PVC 'C' channel of size 50mm x 100 mm with feathered edes shall be fixed on floor and 50 x 75 mm with feathered edges plain/printed/prelim PVC 'C' channel shall be fixed in the ceiling. Sandwich PVC panel shall be inserted in the PVC	Sq.m	23.00	1800.83	Rupees One Thousand Eight Hundred and Eighty Three Paise	41,419.09

Sr. No.	Description	Unit	Quantity	Rate	Rate in Words	Amount (Rs.)
	"c" channel. The first and last M.S. angle should be erected such that it is inside a PVC C channel of size 50 x 75mm. In between adjoining EPS sandwiched PVC partition panel 4mm thick x 75mm width plain PVC sheet feathered at edges shall be stuck on front and back face using solvent cement etc. And additional 4mm thick PVC strip of 40mm width is to be stuck on the interior side of the C channel using PVC solvent adhesive complete as per direction of Engineer in charge, manufacture's specification and drawing.					
56	Providing and fixing Kitchen sink with C.I. or M.S. brackets, painted white including cutting holes in walls and making good the same but excluding fittings. (C) Vitreous China Sink.(i) 600mm x 450mm x 150mm size	No.	1.00	2280.27	Rupees Two Thousand Two Hundred Eighty and Twenty Seven Paise	2,280.27
57	Providing and fixing with down water closet (European type, W.C. Pan) with integral P or S trap including jointing the trap with soil pipe in Cement Mortar 1:1 (1-Cement : 1-fine sand) (Seal and cover to be measured and paid for separately)(A) vitreous China Pattern :(i) in white colour	Each	3.00	1303.71	Rupees One Thousand Three Hundred Three and Seventy One Paise	3,911.13
58	Providing and fixing plastic seat and cover for wash down water closer with C.P. brass hinges and rubber buffers. (B) Black plastic seal and cover.	Each	3.00	291.33	Rupees Two Hundred Ninety One and	873.99



Sr. No.	Description	Unit	Quantity	Rate	Rate in Words	Amount (Rs.)
					Thirty Three Paise	
59	Providing and fixing chromium plated brass half trun flush cock of approved quality including fixing in pipe line etc. complete.(ii) 25mm dia.	Each	3.00	263.77	Rupees Two Hundred Sixty Three and Seventy Seven Paise	791.31
60	Providing and fixing washbasin with single hole for pillar tap with C.I. or M.S. brackets painted white including sutting holes and making good the same but excluding fittings.(A) Vitreous China:(ii) Flat Back washbasin 550 mm x v 400mm size. (i) In white colour.	Each	3.00	1414.18	Rupees One Thousand Four Hundred Fourteen and Eighteen Paise	4,242.54
61	Providing and fixing C.P. brass waste for washbasin or sink. (A) 32mmdia.	Each	4.00	67.91	Rupees Sixty Seven and Ninety One Paise	271.64
62	Providing and fixing M.I. fisher union for washbasin or sink. (A) 32mm dia.	Each	4.00	78.75	Rupees Seventy Eight and Seventy Five Paise	315.00
63	Providing and fixing screw down bib taps of following size.(A) Brass screw down bib tap polished bright. (i) 15mm dia.	Each	4.00	186.83	Rupees One Hundred Eighty Six and Eighty Three Paise	747.32
64	Providing and fixing pillar tap, capstan head, screw down high pressure with	Each	4.00	308.73	Rupees Three	1,234.92

Sr. No.	Description	Unit	Quantity	Rate	Rate in Words	Amount (Rs.)
	screws, shanks and back nuts. (i) 15mm dia.				Hundred Eight and Seventy Three Paise	
65	Providing and fixing Urinal of approved quality including connection with trap and with integral longitudinal flush pipe.(A) Squating plate pattern white earthenware 550mm x 300mm.	Each	2.00	1554.17	Rupees One Thousand Five Hundred Fifty Four and Seventeen Paise	3,108.34
66	Providing and fixing PVC SWR Nahni trap IS 14735 for drain - 100 mm diameter with jali of the following nominal diameter of self cleansing design with C.I sread down or hinged grating including the cost of cutting and making good the walls.	Each	5.00	558.36	Rupees Five Hundred Fifty Eight and Thirty Six Paise	2,791.80
67	Providing laying and jointing in true line and level 15mm dia. U.P.V.C. Pipe (SCH-40) for cold water including fittings as approved by Engineer In Charge. Pipe shall be fixed on the wall with the help of clamp at every two metre C/C or shall be concealed as directed including necessary fittings etc. including testing of pipe and joints and fixing the same with adhesive solvent, including cost of all materials.	Rmt.	15.00	72.65	Rupees Seventy Two and Sixty Five Paise	1,089.75
68	Providing laying and jointing in true line and level 25mm dia. U.P.V.C. Pipe (SCH- 40) for cold water including fittings as approved by Engineer In Charge. Pipe shall be fixed on the wall with the help of clamp at every two metre C/C or shall be concealed as	Rmt.	210.00	91.84	Rupees Ninety One and Eighty Four Paise	19,286.40

Sr. No.	Description	Unit	Quantity	Rate	Rate in Words	Amount (Rs.)
	directed including necessary fittings etc. including testing of pipe and joints and fixing the same with adhesive solvent, including cost of all materials.					
69	Providing and fixing to wall ceiling and floor 10.0 Kg.F/Cm2 working pressure polythene pipes of the following outside Dia. Low density, complete with special falnge compression type fittings, wall clipsetc. including making good the wall ceiling and floor.(F)75 mm	Rmt.	25.00	277.43	Rupees Two Hundred Seventy Seven and Forty Three Paise	6,935.75
70	Providing and fixing to wall ceiling and floor 10.0 Kg.F/Cm2 working pressure polythene pipes of the following outside Dia. Low density, complete with special falnge compression type fittings, wall clipsetc. including making good the wall ceiling and floor.(G)110 mm	Rmt.	30.00	240.21	Rupees Two Hundred Forty and Twenty One Paise	7,206.30
71	Constructing brick masonry chamber for underground C.I. Inspection chamber and bends with briocks having croshing strength not less than 35Kg. Cm2 in C.M. 1:5 C.I. cover with frame (Light duty) 455mm x 610mm intenal dimensions total weight of cover with frame to be not less than 38Kg.. (Wt. of cover 23 Kg.) and Wt. of frame 15Kg. ) (R.C.C. top slabe with 1:2:4 mix (1-cement :2- coarse sand :4-graded stone aggregate 20mm size) foundation concrete 1:5:10 inside plaster 15mm thick with cement mortar 1:3 finished smooth with a floating coat of neat cement on walls and bed concrete etc. complete.(i) Inside dimensions 455mmx	Each	9.00	2932.93	Rupees Two Thousand Nine Hundred Thirty Two and Ninety Three Paise	26,396.37

Sr. No.	Description	Unit	Quantity	Rate	Rate in Words	Amount (Rs.)
	610mm and 450mm deep for single pipe line. (more than 10 ton)					
72	Providing and fixing Gun metal check or non-return fullway wheel valve.(C) 25mm dia.	No.	6.00	420.63	Rupees Four Hundred Twenty and Sixty Three Paise	2,523.78
73	Supplying Rotationally moulded HDPE storage tank with ISI Mark of approved make incl. all taxes transportation octroi etc. complete. Storage Tanks With ISI Mark (with outside Black colour & inside lining) 500 Litre	No.	3.00	5148.55	Rupees Five Thousand One Hundred Forty Eight and Fifty Five Paise	15,445.65
74	Providing erecting and fixing double coated ISI water tank of required capacity each with all necessary fitting and connection etc. complete on terrace.	Litre	1500.00	3.95	Rupees Three and Ninety Five Paise	5,925.00

Sr. No.	Description	Unit	Quantity	Rate	Rate in Words	Amount (Rs.)
75	Providing and supplying ISI Standard R.C.C. pipes(of Sulphate Resisting Cement) in standard lengths of following class and diameter suitable for either collar joints or rubber ring joints including all taxes, insurance, transportation, freight charges, octroi, inspection charges, loading, unloading, conveyance to departmental stores, stacking etc. complete. Note : One collar should be supplied with each full length plain ended RCC pipe, cost included in rates below. One rubber ring should be supplied with each full length socketed pipe, cost included in rates below. Class NP3 Test Pressure 0.7 Kg./sq.cm 200 mm dia pipe ID	Rmt.	80.00	417	Rupees Four Hundred Seventeen Only	33,360.00
76	Providing and supplying ISI mark G. I. pipes with Couplings of following class and diameter including all taxes, insurance, transportation, freight charges, octroi, inspection charges, loading, unloading, conveyance to departmental stores, stacking etc. complete. (IS -1239) (Not for well/tube well column pipe) Heavy Duty 50 mm	Rmt.	100.00	435	Rupees Four Hundred Thirty Five Only	43,500.00
77	Providing and supplying in standard length ISI mark rigid unplasticised PVC pipes suitable for portable water with ringfit joint including cost of rings, as per IS specification no 4985/1988 including all local and central taxes, transportation, freight charges, octroi, inspection charges, loading, unloading, conveyance to the departmental stores and including cost of jointing material etc.	Rmt..	60.00	199	Rupees One Hundred Ninety Nine Only	11,940.00

Sr. No.	Description	Unit	Quantity	Rate	Rate in Words	Amount (Rs.)
	Test Pressure 6 Kg./cm2 Pipe Dia. 110 mm					
78	Lowering, laying and jointing R. C. C. pipes in C. M. 1:1 1/2 of following diameters in proper position, grade and alignment at all level as directed by Engineer-in-charge including conveyance from stores to site of work, labour, giving hydraulic testing as per ISI code. 200 mm dia pipe ID	Rmt.	80.00	101.2	Rupees One Hundred One and Twenty Paise	8,096.00
79	Lowering, laying and jointing G. I. pipes with G. I. specials of following diameters in proper position, grade and alignment as directed by Engineer-in-charge including conveyance from stores to site of work, labour, giving hydraulic testing, etc. complete Pipe Dia.50 mm	Rmt.	100.00	20.7	Rupees Twenty and Seventy Paise	2,070.00
80	Lowering, laying and jointing PVC pipes and specials of following class and diameter including cost of conveyance from stores to site of works including coat of labour, material,except cement solvent, giving satisfactory hydraulic testing as per ISI code. Pipe Dia. 110 mm	Rmt.	60.00	21.85	Rupees Twenty One and Eighty Five Paise	1,311.00

Sr. No.	Description	Unit	Quantity	Rate	Rate in Words	Amount (Rs.)
81	Providing and constructing Sewer manholes, scraper manholes and unit house connection chamber, as per the type design in brick masonry in C. M. 1:5 and inside and outside 15mm thick plastering in C. M. 1:3 necessary 100 mm coping with reinforcement in RCC M- 200 fixing C. I. steps and fixing manhole frame and covers (But excluding supply of manhole frame and covers) over manholes and house connection chambers and fixing Manhole covers (but excluding supplying of manhole covers) over scraper manhole etc. complete, providing and fixing safety chain wherever necessary as per the stipulations in the type desing complete (excl. excavation). a) Manhole type 'A' Circular type having inside diameter of 1200 mm for depth up to 1.5 mt depth ( for 150 mm to 500 mm dia sewer ). i) Manhole type 'A' as above but up to 1.0 M depth.	No.	5.00	14005.85	Rupees Fourteen Thousand Five and Eighty Five Paise	70,029.25
82	ii) Extra Depth beyond 1.0 M but upto 1.5 m depth for type "A" manhole above.	Rmt.	2.00	7622.2	Rupees Seven Thousand Six Hundred Twenty Two and Twenty Paise	15,244.40
83	b) Manhole type 'B' Circular type having inside diameter of 1500 mm for depth from 1.5 mt to 4.0 mt ( for 150 mm to 600 mm dia sewer ). i) Manhole type 'B' as above but up to	No.	1.00	24283.4	Rupees Twenty Four Thousand Two	24,283.40

Sr. No.	Description	Unit	Quantity	Rate	Rate in Words	Amount (Rs.)
	1.5 mt depth.				Hundred Eighty Three and Forty Paise	
84	ii) Extra Depth beyond 1.5 M but upto 4.0 m depth for type "B" manhole above.	Rmt.	1.00	14159.95	Rupees Fourteen Thousand One Hundred Fifty Nine and Ninety Five Paise	14,159.95
85	RCC precast MH frame & cover manufacture, supply & delivery at store or at site of work precast RCC M200 frame & cover suitable to drainage MH and as per type design & drawing including cost of reinforcement MS angle or flat, curing mold work etc. Heavy Duty Frame suitable for 50 cm opening of MH	No.	6.00	1121	Rupees One Thousand One Hundred Twenty One Only	6,726.00
86	Cover suitable for 50 cm opening of MH	No.	6.00	1173	Rupees One Thousand One Hundred Seventy Three Only	7,038.00
87	House connection chamber light duty Frame	No.	7.00	813	Rupees Eight Hundred Thirteen Only	5,691.00
88	Cover	No.	7.00	920	Rupees Nine	6,440.00



Sr. No.	Description	Unit	Quantity	Rate	Rate in Words	Amount (Rs.)
					Hundred Twenty Only	
89	C.I. Manhole Frame & Cover	Kg.	75.00	58	Rupees Fifty Eight Only	4,350.00
90	Constructing brick masonry chamber for underground C.I. Inspection chamber and bends with bricks having crushing strength not less than 35Kg/Cm <sup>2</sup> in C.M. 1:5 C.I. cover with frame (Light duty) 455mm x 610mm intenal dimensions total weight of cover with frame to be not less than 38Kg. (Wt. of cover 23 Kg.) and Wt. of frame 15Kg. ) (R.C.C. top slabe with 1:2:4 mix (1-cement: 2- coarse sand :4-graded stone aggregate 20mm size) foundation concrete 1:5:10 inside plaster 15mm thick with cement mortar 1:3 finished smooth with a floating coat of neat cement on walls and bed concrete etc. complete.(i) Inside dimensions 455mmx 610mm and 450mm deep for single pipe line.	Each	7.00	2932.93	Rupees Two Thousand Nine Hundred Thirty Two and Ninety Three Paise	20,530.51
91	Extra over items 24.44 for every additional depth of 0.1M. of part thereof beyond 450mm depth for Brick masonry chamber.(i) for 455mm x 610mm size.	No.	3.85	242.39	Rupees Two Hundred Forty Two and Thirty Nine Paise	933.20
92	Providing and fixing 50 cm wide M.S. Ladder fabricated from M.S. Flats 10 mm x 75 mm with 20 mm dia steel bar steps in double rows, @ 30 cm C/C. The include stays of 10 mm x 50 mm flats fixed at 3 meter C/C with welding anchoring and 3 coats anticorrosive paint.	Rmt.	4.00	3392.5	Rupees Three Thousand Three Hundred Ninety Two and Fifty	13,570.00

Sr. No.	Description	Unit	Quantity	Rate	Rate in Words	Amount (Rs.)
					Paise	
93	Providing and fixing at site of work M. S. iron ladder with Rly. freight, loading, unloading, carting & all taxes etc. comp as directed including paints 2 coats etc comp.	Kg.	100.00	72	Rupees Seventy Two Only	7,200.00
94	Making connection of sewer line with existing manhole including breaking into and making good the walls, floors with cement concrete 1:2:4 mix (1 cement : 2 coarse sand : 4 graded stone aggregate 20 mm nominal size) cement plastered on both sides with cement mortar 1:3 (1 cement : 3 coarse sand), finished with a floating coat of neat cement and making necessary channels for the drain etc. complete For pipes 100 to 250 mm diameter	No.	1.00	810.45	Rupees Eight Hundred Ten and Forty Five Paise	810.45
95	Trenching in ordinary soil up to a depth of 60 cm including removal and stacking of serviceable materials and then disposing of surplus soil, by spreading and neatly leveling within a lead of 50 m and making up the trenched area to proper levels by filling with earth or earth mixed with sludge or / and manure before and after flooding trench with water (excluding cost of imported earth, sludge or manure).	Cu.m	446.00	78.88	Rupees Seventy Eight and Eighty Eight Paise	35,180.48
96	Supplying and stacking of good earth at site including royalty and carriage upto 5 km complete (earth measured in stacks will be reduced by 20% for payment).	Cu.m	387.00	520.76	Rupees Five Hundred Twenty and Seventy Six Paise	2,01,534.12

Sr. No.	Description	Unit	Quantity	Rate	Rate in Words	Amount (Rs.)
97	Supplying and stacking sludge at site including royalty and carriage upto 5 km complete (sludge measured in stacks will be reduced by 8% for payment).	Cu.m	148.50	296.94	Rupees Two Hundred Ninety Six and Ninety Four Paise	44,095.59
98	Supplying and stacking at site dump manure from approved source, including carriage upto 5 km complete (manure measured in stacks will be reduced by 8% for payment) : 4.1 Screened through sieve of I.S. designation 20 mm	Cu.m	99.00	256.69	Rupees Two Hundred Fifty Six and Sixty Nine Paise	25,412.31
99	4.2 Screened through sieve of I.S. designation 16 mm	Cu.m	99.00	293.61	Rupees Two Hundred Ninety Three and Sixty One Paise	29,067.39
100	4.3 Screened through sieve of I.S. designation 4.75 mm	Cu.m	99.00	323.1	Rupees Three Hundred Twenty Three and Ten Paise	31,986.90
101	Rough dressing the trenched ground including breaking clods.	Cu.m	990.00	1.52	One Rupee and Fifty Two Paise	1,504.80
102	Uprooting weeds from the trenched area after 10 to 15 days of its flooding with water including disposal of uprooted vegetation.	Cu.m	990.00	4.95	Rupees Four and Ninety Five Paise	4,900.50
103	Fine dressing of the ground.	Cu.m	990.00	3.74	Rupees Three and Seventy Four Paise	3,702.60

Sr. No.	Description	Unit	Quantity	Rate	Rate in Words	Amount (Rs.)
104	Spreading of sludge, dump manure and/or good earth in required thickness as per direction of officer-in-charge (cost of sludge, dump manure and/ or good earth to be paid separately).	Cu.m	148.50	52.87	Rupees Fifty Two and Eighty Seven Paise	7,851.20
105	Mixing earth and sludge or manure in the required proportion specified or directed by the Officer-in-charge	Cu.m	297.00	36.92	Rupees Thirty Six and Ninety Two Paise	10,965.24
106	Supplying & Stacking of Selection No.1 Grass at site fresh & free from weeds having proper roots in green including loading, unloading, carriage and all taxes paid etc.and as per direction of officer in charge.	Cu.m	990.00	51.31	Rupees Fifty One and Thirty One Paise	50,796.90
107	Grassing with selection No. 1 grass including watering and maintenance of the lawn for 60 days or more till the grass forms a thick lawn, free from weeds and fit for mowing including supplying good earth, if needed (the grass and earth shall be paid for separately). In rows 5 cm apart in both directions	Cu.m	990.00	17.88	Rupees Seventeen and Eighty Eight Paise	17,701.20
108	With grass Turf	Cu.m	990.00	13.43	Rupees Thirteen and Forty Three Paise	13,295.70

Sr. No.	Description	Unit	Quantity	Rate	Rate in Words	Amount (Rs.)
109	Preparation of beds for hedging and shrubbery by excavating 60 cm deep and trenching the excavated base to a further depth of 30 cm, refilling the excavated earth after breaking clods and mixing with sludge or manure in the ratio of 8:1 (8 parts of stacked volume of earth after reduction by 20% : one part of stacked volume of sludge or manure after reduction by 8%), flooding with water, filling with earth if necessary, watering and finally fine dressing, leveling etc. including stacking and disposal of materials declared unserviceable and surplus earth by spreading and leveling as directed, within a lead of 50 m, lift up to 1.5 m complete (cost of sludge, manure or extra earth to be paid for separately)	Cu.m	135.00	225.08	Rupees Two Hundred Twenty Five and Eight Paise	30,385.80
110	Plantation of Trees, Shrubs, and Hedge at site i/c watering and removal of unserviceable material's as per direction of officer in charge (including cast of plant & water) Trees Plant	Each	50.00	7.37	Rupees Seven and Thirty Seven Paise	368.50
111	Shrubs Plant	Each	50.00	3.69	Rupees Three and Sixty Nine Paise	184.50
112	Hedge Plant	Each	100.00	2.47	Rupees Two and Forty Seven Paise	247.00

Sr. No.	Description	Unit	Quantity	Rate	Rate in Words	Amount (Rs.)
113	Digging holes in ordinary soil and refilling the same with the excavated earth mixed with manure or sludge in the ratio of 2:1 by volume (2 parts of stacked volume of earth after reduction by 20% : 1 part of stacked volume of manure after reduction by 8%) flooding with water, dressing including removal of rubbish and surplus earth, if any, with all leads and lifts (cost of manure, sludge or extra good earth if needed to be paid for separately) : Holes 1.2 m dia and 1.2 m deep	Each	50.00	338.86	Rupees Three Hundred Thirty Eight and Eighty Six Paise	16,943.00
114	Holes 90 cm dia, and 90 cm deep	Each	50.00	144.53	Rupees One Hundred Forty Four and Fifty Three Paise	7,226.50
115	Holes 60 cm dia, and 60 cm deep	Each	50.00	44.19	Rupees Forty Four and Nineteen Paise	2,209.50
116	Holes 45 cm dia, and 45 cm deep.	Each	50.00	18.89	Rupees Eighteen and Eighty Nine Paise	944.50
117	Providing and displaying of Aglaonema Butterfly having ht.30 cm 10 to 12 fresh, healthy and attractive colorful leaves, well developed in 25 cm size Earthen pot/Plastic pot & as per direction of the officer-in-charge.	Each	50.00	186.35	Rupees One Hundred Eighty Six and Thirty Five Paise	9,317.50
118	Providing and displaying of Araucaria cookie having ht. 1.80 m to 1.95 m, straight, well developed, fresh and healthy with lush green leaves from	Each	50.00	569.39	Rupees Five Hundred Sixty Nine	28,469.50

Sr. No.	Description	Unit	Quantity	Rate	Rate in Words	Amount (Rs.)
	bottom to top in 30 cm size of Earthen pot/Plastic pot & as per direction of the officer-in-charge.				and Thirty Nine Paise	
119	Providing and displaying of Areca Palm having ht. 2.40 m to 2.70 m with 12 to 14 suckers, well developed, fresh and healthy with lush green foliage in 35 cm size of Bucket type cement pots & as per direction of the officer-in-charge.	Each	50.00	598.37	Rupees Five Hundred Ninety Eight and Thirty Seven Paise	29,918.50
120	Point wiring for Light / Fan/ Bell/ Primary Point with 2-1.5 sq. mm & earth wire of 1.5 sq. mm (green) both are of ISI marked 1.1 kv grade FRLS PVC insulated multi strand copper wires upto max length of 10 mt, in below type of pipe erected with 6A Tissino Type ISI marked flush type switch / bell push and accessories erected on Metal / PVC/Wooden Box covered with 3 mm thick PC(Polycarbonate) /Acrylic/Laminated sheet. with necessary Lamp holder/ceiling rose / H.D.Connector as directed. NOTE:1. For use of ZHFR/HRFR Copper wires in place of FRLS PVC wires add 5% in Item of Point wiring Item No 1-1-1 to 1-2-5 & 1-5-1 & 1-5-2. (a) with medium class Rigid PVC pipe and accessories erected flushed on wall/ceiling complete Cat. III	Pt.	50.00	343.71	Rupees Three Hundred Forty Three and Seventy One Paise	17,185.50

Sr. No.	Description	Unit	Quantity	Rate	Rate in Words	Amount (Rs.)
121	Point wiring for independent PLUG with following size mains earth wire of 1.5 sq.mm (green) both are of ISI marked 1.1 KV grade FRLS PVC insulated multi strand copper wires upto 10 mt length, in following below of pipe erected complete with ISI marked 3 / 5 Pin socket and tissino type switch erected with earth continuity connection erected on Metal / PVC/Wooden box covered with 3 mm thick PC(Polycarbonate) / Acrylic/Laminated sheet. NOTE:1. For use of ZHFR/HRFR Copper wires in place of FRLS PVC wires add 5% in Item of Point wiring Item No 1-1-1 to 1-2-5 & 1-5-1 & 1-5-2. [A] For 6 amp plug and 6 amp switch with 2-1.5 sq. mm Cu. Mains from near by switchboard/db board upto 6 mt. (a) with medium class Rigid PVC pipe and accessories erected flushed on wall/ceiling complete Cat. III	Ea.	27.00	303	Rupees Three Hundred Three Only	8,181.00
122	[B] 6/16A Plug and 16 amp switch with 2-2.5 sq. mm Cu. Mains from mcb d b boards. (a) with medium class Rigid PVC pipe and accessories erected flushed on wall/ceiling complete	Ea.	12.00	486.7	Rupees Four Hundred Eighty Six and Seventy Paise	5,840.40
123	Providing and erecting ISI mark Medium class RIGID PVC PIPES of following size complete to be erected on/in wall or ceiling erected with necessary PVC fittings & Junction boxes fixed with adhesive solution & Clamps with following dia of pipes, in approved manner as directed	Rmt.	200.00	23.44	Rupees Twenty Three and Forty Four Paise	4,688.00



Sr. No.	Description	Unit	Quantity	Rate	Rate in Words	Amount (Rs.)
	(a) 20 mm					
124	(b) 25 mm	Rmt.	150.00	32.46	Rupees Thirty Two and Forty Six Paise	4,869.00
125	Providing and erecting Mains with 1.1 KV grade FRLS PVC insulated ISI marked stranded Copper conductor wire in following type of pipe to be erected concealed in /flushed on wall/ceiling, with 1.5 sq. mm copper conductor FRLS PVC insulated stranded wire of green colour for earth continuity of following size (A) with medium class Rigid PVC pipe and accessories (a) 2 wire 1.5 sq. mm	Rmt.	200.00	61.32	Rupees Sixty One and Thirty Two Paise	12,264.00
126	(b) 2 wire 2.5 sq. mm	Rmt.	300.00	81.16	Rupees Eighty One and Sixteen Paise	24,348.00
127	providing and erecting Mains with 1.1 KV grade FRLS PVC insulated ISI marked stranded Copper conductor wire in following type of pipe to be erected in / on wall / ceiling with 2.5 sq. mm copper conductor FRLS PVC insulated stranded wire of green colour for earth continuity of following size (A) with medium class Rigid PVC pipe and accessories (a) 2 wire 4 sq. mm	Rmt.	150.00	110.92	Rupees One Hundred Ten and Ninety Two Paise	16,638.00

Sr. No.	Description	Unit	Quantity	Rate	Rate in Words	Amount (Rs.)
128	Providing & erecting Approved make Ceiling Fan with double ball bearing ISI mark with Condenser 230 volt A.C.50 Hz 1200 mm sweep complete having 3 blades aluminium body and blade sets having ornamental design shanks , canopy erected with earthing. [ Make shall be approved by Engineer in Charge]	No.	8.00	2218.39	Rupees Two Thousand Two Hundred Eighteen and Thirty Nine Paise	17,747.12
129	Supplying and erecting LED indoor fittings with LEDs of wattage 0.2 Watt to 0.5 Watt assembled on single MCPCB, with housing used as a heat sink shall be made of thick sheet Steel conforming to IS: 513/CRCA/ aluminium die cast powder coated and high U.V. & corrosion resistance with diffuser with company mark/name 160V to 270V, Power Factor more than 0.9, THD < 15%,CCT 3000 K to 6500K, Luminaire efficacy> 85 lumens/watt ,LED driver efficiency > 85 % (fitting required LM-79 & LM-80 Certificates)(NOTE: Below description have shown ranges of Wattage capacity of LED fittings.The Engineer incharge may select any wattage capacity between the ranges shown.) (A) Tube Light with integral driver (iv) 22-24 Watts, Surge - 2KV,IP-20, conventional 4 feet Cat. III	Ea.	28.00	432.86	Rupees Four Hundred Thirty Two and Eighty Six Paise	12,120.08
130	Supplying and erecting led lamps with following wattage capacity of 220 to 240 voltage, minimum 15000 burning hours life, 500 V in built-surge protection,Polycarbonate diffuser, mounting suitable for E14 / E27 / B22 lamp holders, pf >= 0.5 (A) LED Lamps integral type, with PC	Mtr.	10.00	220.94	Rupees Two Hundred Twenty and Ninety Four Paise	2,209.40

Sr. No.	Description	Unit	Quantity	Rate	Rate in Words	Amount (Rs.)
	diffuser suitable LAMP holder (iii) 10 to 15 watts Cat III					
131	Supplying and erecting LED street light / Flood light fittings with High power White LEDs wattage of 3 Watt and above assembled on single MCPCB, efficiency more than 130 lm/w and corrosion free High pressure die cast aluminum housing with smooth finish powder coated and heat sink extruded aluminium with diffuser and Polycarbonate optics/ lenses, with toughened glass with company mark/name engraved or embossed 160 to 270 V, Power Factor more than 0.95, THD < 10 %, CCT 3000 K to 5700K, Uniformity ratio >0.45, Luminaire efficacy > 100 lumens/watt . LED driver efficiency > 85 %.( fittings required LM-79 & LM-80 certificates)(NOTE: Below description have shown ranges of Wattage capacity of LED fittings.The Engineer incharge may select any wattage capacity between the ranges shown.) (A) Street Light (IP-65), Surge protection -4KV integral and ,Light must have 440VAC line supply with over-voltage protection. (iv) above 90 to 120 watts	Ea.	7.00	7665.18	Rupees Seven Thousand Six Hundred Sixty Five and Eighteen Paise	53,656.26
132	Supplying and erecting Flexible PVC insulated multi strand multi core 1.1 kv grade ISI marked copper wires of following size to be erected as directed. (e) 1.50 Sq.mm 3 core round PVC	Mtr.	350.00	46	Rupees Forty Six Only	16,100.00

Sr. No.	Description	Unit	Quantity	Rate	Rate in Words	Amount (Rs.)
	sheathed					
133	Providing and erecting Sheet Steel powder coated MCB distribution board - flush / surface mounted fitted with busbar, neutral link, earth bar and DIN rail, Conforms to IS 8623-1 & 3, IEC 61439-1 & 3 without MCB to house appropriate nos. of MCBs.(The DBs should be used of same company of MCB to be used) suitable for (A) single phase incoming and horizontal single phase outgoing (b) sheet steel double door (IP-43) (iv)12 way	Ea.	3.00	1570.91	Rupees One Thousand Five Hundred Seventy and Ninety One Paise	4,712.73
134	(B) three phase incoming and single phase horizontal type outgoing Per phase isolation type (PPI) (b) sheet steel double door (v) 16 way	Ea.	1.00	4914.73	Rupees Four Thousand Nine Hundred Fourteen and Seventy Three Paise	4,914.73
135	providing and erecting Miniature circuit breaker single pole 6A to 25A suitable to operate on 240 V A.C. system and having breaking capacity 10 KA to be erected in existing box. confirming to IS 8828/1996 with ISI Mark Cat. III	Ea.	16.00	117.23	Rupees One Hundred Seventeen and Twenty Three Paise	1,875.68

Sr. No.	Description	Unit	Quantity	Rate	Rate in Words	Amount (Rs.)
136	Supplying & erecting earth pit of minimum bore dia.150mm size approved make Earthing Electrode consisting Pipe-in-Pipe Technology as per IS 3043-1987 made of corrosion free hot dipped G.I.Pipes having Outer pipe dia of 50mm having 80-200 Micron galvanising, Inner pipe dia of 25 mm having 200-250 Micron galvanising, connection terminal dia of 12mm with constant ohmic value surrounded by highly conductive compound with high charge dissipation suitable for following type of applications with chamber and heavy duty cover.(approved make OEM has to submit test certificate) & having back filling compound of (B) Inner chemical (CCM Compound)- Resistivity:- 0.2 W/ meter testing as per IEC 62561-2017, Voltage drop:- < 1 volt at no load & dry form, Sulphar content:- <2%(C) Back fill Compound :- Earthing compound should be capable to retain moisture for long time Necessary test report must be submitted. (b)For Electrical installation up to 11 KV in normal soil. Length of Pipe : 2.00 mtrs Back filling Compound :1 No. Bag of 25 Kg..	Ea.	6.00	6067.21	Rupees Six Thousand Sixty Seven and Twenty One Paise	36,403.26
137	Providing and erecting HOT deep Galvanised iron strip wire 8 to 16 SWG.	Kg.	15.00	81.16	Rupees Eighty One and Sixteen Paise	1,217.40
138	Supplying & erecting single phase approved make industrial exhaust fan suitable for medium duty ring mounted low noise operation suitable for	Ea.	2.00	2164.29	Rupees Two Thousand One	4,328.58

Sr. No.	Description	Unit	Quantity	Rate	Rate in Words	Amount (Rs.)
	medium duty having following dia size and maximum speed in RPM [A] 305 mm dia 900 RPM Cat. II				Hundred Sixty Four and Twenty Nine Paise	
139	Supply, installation, testing & commissioning single girder type fully electrically operated EOT crane with electrically operated hoist, class II duty, geared travelling trolley with seven meter lift complete with long travel rail track (40 mm sq. bar), moving or cross girder, all three motions electrically operated by suitable rating motor IP 54, control panel & down pendant control block, brake, safety device, cables form motor to starter panel & other required accessories & tested as per IS Specifications. Capacity 3 ton, span 9m - 12m, Lifting 6m - 10m and long travel 20 m	set	1.00	554250	Rupees Five Lac Fifty Four Thousand Two Hundred Fifty Only	5,54,250.00
140	Single phase borewell submersible pump motor set MOC: Casing: CI-FG260, Impeller: Bronze & Shaft: SS:410 Discharge -20 LPS, Head 90 Mtr, HP- 1.5	No.	1.00	10750	Rupees Ten Thousand Seven Hundred Fifty Only	10,750.00
141	Monoset sub. pump 3 phase 400/440 vott, 50 c/s. A.C. Supply & 2900 RPM , as per IS 14220 MOC : Casing: CI-FG260, Impeller : Bronze & Shaft : SS:41 Discharge -220 LPM, Head 22.5 Mtr, HP- 4	No.	1.00	14299	Rupees Fourteen Thousand Two Hundred Ninety Nine Only	14,299.00

Sr. No.	Description	Unit	Quantity	Rate	Rate in Words	Amount (Rs.)
142	DOL / Star Delta starter suitable for local & remote pump control application consisting of MPCB, overload relay and contactors as per Type II coordination including digital voltmeter, analogue ammeter with selector switch, run hour meter, required protective relays & control accessories. b)D. O. L. up to 5 HP	No.	2.00	6924	Rupees Six Thousand Nine Hundred Twenty Four Only	13,848.00
143	PVC insulated flat submersible cable as per detailed technical specifications of R/C of GWSSB conforming to IS 694, IEC 60227 / 60228. b) 1 R x 3 C x 2.5 mm2	Rmt.	200.00	58	Rupees Fifty Eight Only	11,600.00
144	Supplying and erecting approved make Octagonal pole made from HR sheet steel. The pole should be made as per IS. and shall be coated with hot dip galvanizing as per IS 2629/2633/4759, suitable suspend local wind speed with integral Junction box consist of terminal plate of min 6mm Hylam sheet, standard profile 35mmX7.5mm Din-Rail for MCB Mounting, stud type terminal and arrangement for cable termination to be erected With Suitable foundation (Included) as per details given by manufacturer considering site requirement. (D) 6 Mtr. Long 70 mm Top X 135 mm bottom dia, 3 mm thickness with 200mmX200mmX12mm base plate, 4-M20 Bolts and 600mm long J-Bolt.Approx Pole weight 59 Kg.	Ea.	18.00	8630.09	Rupees Eight Thousand Six Hundred Thirty and Nine Paise	1,55,341.62

Sr. No.	Description	Unit	Quantity	Rate	Rate in Words	Amount (Rs.)
145	Providing and erecting street light pole bracket comprising main B Class GI pipe of 4.2 cm/require outside dia. complete with suitable B Class G.I sleeve tubing of approx. 45cms.length and suitable for 76.5 mm / 80mm. / require size pole top having sufficient fasteners for fixing the brackets and having spread of 1 mtr. length with suitable rise as per site condition & suitable welded stiffener reducer and nipple with check nut complete painted with one coat of Red oxide / PU base primer and two coats of Aluminium / PU paint. paint with following nos of arms. [A] Single Arm bracket 1 Mtr	Ea.	20.00	645.68	Rupees Six Hundred Forty Five and Sixty Eight Paise	12,913.60



Sr. No.	Description	Unit	Quantity	Rate	Rate in Words	Amount (Rs.)
146	<p>Supplying, erecting, testing, commissioning approved make M.S. Polygonal High Mast Pole having following general Specification.</p> <p>(a) Polygonal Section fabricated from M.S. Plate confirms BSEN 10025 &amp; Hot deep galvanized minimum 65/86 micron (as per IS 2629 /1985) Lantern carriage with ring and rubber lines for erection of luminaries of suitable site.</p> <p>(b) Maximum telescopic section not more than four</p> <p>(c) Double drum gear pipe motorized winch with 6mm dia S.S. Rod (For 16 mtr and above size)</p> <p>(d) Approved make L.E.D. aviation light = 1 No. Lightning arrestor = 1 No. with necessary wiring of 2.5 sq.mm 5 core ISI copper cable Unarmoured.</p> <p>(e) Bottom most section suitable for mounting reversible motor and switchgears having door not more than 1400mm x 300mm with waterproof gasket &amp; hinges &amp; locking arrangement.</p> <p>(f) Pole structure comprises suitable size of reversible motor, cable and necessary switchgears with control panel.</p> <p>(g) bottom section shall have suitable size of thickness supports ribs foundation bolts nuts etc.</p> <p>(h) Item not comprises the cost of lanterns.</p> <p>(i) Necessary Cement Concrete foundation as per IS including testing &amp; commissioning of the entire structure for following size of High Mast poles [7] High Mast 20 Mtr. TOP A/F 150 Mm, BOTTOM A/F 400 Mm, No. of Sec. No. -</p>	Ea.	1.00	218475.6	Rupees Two Lac Eighteen Thousand Four Hundred Seventy Five and Sixty Three Paise	2,18,475.63

Sr. No.	Description	Unit	Quantity	Rate	Rate in Words	Amount (Rs.)
	2, Bottom Thickness - 4 mm, Top Sec. - 3 mm, Size Base Plate -dia.580 mm x 20 mm thick, Foundation Bolt Size M27 x 850mm , Qty - 10 Nos., Suitable for mounting Fitting of Light - 12 Nos.					

Sr. No.	Description	Unit	Quantity	Rate	Rate in Words	Amount (Rs.)
147	Supplying and erecting LED street light / Flood light fittings with High power White LEDs wattage of 3 Watt and above assembled on single MCPCB, efficiency more than 130 lm/w and corrosion free High pressure die cast aluminum housing with smooth finish powder coated and heat sink extruded aluminium with diffuser and Polycarbonate optics/ lenses, with toughened glass with company mark/name engraved or embossed 160 to 270 V,Power Factor more than 0.95, THD < 10 %, CCT 3000 K to 5700K,Uniformity ratio >0.45, Luminaire efficacy> 100 lumens/watt . LED driver efficiency > 85 %.( fittings required LM-79 & LM-80 certificates)(NOTE: Below description have shown ranges of Wattage capacity of LED fittings.The Engineer incharge may select any wattage capacity between the ranges shown.) (A) Street Light (IP-65), Surge protection -4KV integral and ,Light must have 440VAC line supply with over-voltage protection. (iii) Above 60 to 90 watts Cat III	Ea.	20.00	6975.31	Rupees Six Thousand Nine Hundred Seventy Five and Thirty One Paise	1,39,506.20
148	(vii)Above 200 to 250 watts Cat III	Ea.	12.00	11993.75	Rupees Eleven Thousand Nine Hundred Ninety Three and Seventy Five Paise	1,43,925.00

Sr. No.	Description	Unit	Quantity	Rate	Rate in Words	Amount (Rs.)
149	Supplying and erecting Flexible PVC insulated multi strand multi core 1.1 kv grade ISI marked copper wires of following size to be erected as directed. (e) 1.50 Sq.mm 3 core round PVC sheathed	Mtr.	160.00	46	Rupees Forty Six Only	7,360.00
150	(k) 4.00Sq.mm 4 core round PVC sheathed	Mtr.	30.00	176.75	Rupees One Hundred Seventy Six and Seventy Five Paise	5,302.50
151	Supply, laying, testing & commissioning 1.1 kV grade, XLPE insulated, stranded Aluminium conductor, galvanised steel flat strip / round wire armoured, extruded PVC type ST2 sheathed, heavy duty cable (to be laid on wall surface with necessary clamps / in existing cable trench / cable trays / conduit / pipe sleeves at road crossing or floor as per site requirement) conforming to IS: 7098 (Part-1) & IEC: 60502 (Part-1) of following sizes: (d) 4 Core x 10 Sq.m.m	Mtr.	610.00	111.55	Rupees One Hundred Eleven and Fifty Five Paise	68,045.50
152	Providing & fitting heavy duty brass cable glands (nickel-plated) with washers & rubber ring conforming to IS, suitable for 3, 3½ & 4 core cables of following type & sizes: Double Compression Brass Cable Glands d) 10 Sq.m.m	Ea.	38.00	138	Rupees One Hundred Thirty Eight Only	5,244.00
153	Cable Terminals (Lugs) Providing & fitting crimping type Cable Terminals (Lugs) conforming to IS of following types and sizes Aluminium Tubular Terminals (Long Barrel) (in Sq. mm.)	Ea.	152.00	2.3	Rupees Two and Thirty Paise	349.60

Sr. No.	Description	Unit	Quantity	Rate	Rate in Words	Amount (Rs.)
	d) 10 Sq.m.m					
154	Providing & laying approved make Double walled corrugated pipes (DWC) of polyethylene(conforming to IS 14930 II )with necessary connecting accessories of same material at required depth for laying of cable. below ground / road surface for enclosing cable (A)50 mm inner dia	Mtr.	600.00	64.93	Rupees Sixty Four and Ninety Three Paise	38,958.00
155	Providing and erecting Pipe type earthing having 150 cms.long and 2.5 cms. dia. galvanised iron pipe with coupling and buch buried in specially prepared earth pit complete with necessary 8 SWG earth wire.	Ea.	18.00	387.77	Rupees Three Hundred Eighty Seven and Seventy Seven Paise	6,979.86
156	For using salt and charcoal / coke as required for pipe type earthing.	Mtr	18.00	180.36	Rupees One Hundred Eighty and Thirty Six Paise	3,246.48
157	Providing and erecting Sheet Steel powder coated MCB distribution board - flush / surface mounted fitted with busbar, neutral link, earth bar and DIN rail, Conforms to IS 8623-1 & 3, IEC 61439-1 & 3 without MCB to house appropriate nos. of MCBs.(The DBs should be used of same company of MCB to be used) suitable for (b) sheet steel double door (IP-43) (H) Single phase 12 way SS Double door	Ea.	5.00	1570.91	Rupees One Thousand Five Hundred Seventy and Ninety One Paise	7,854.55

Sr. No.	Description	Unit	Quantity	Rate	Rate in Words	Amount (Rs.)
158	providing and erecting Miniature circuit breaker single pole 6A to 25A suitable to operate on 240 V A.C. system and having breaking capacity 10 KA to be erected in existing box. confirming to IS 8828/1996 with ISI Mark Cat.III	Ea.	34.00	117.23	Rupees One Hundred Seventeen and Twenty Three Paise	3,985.82
159	Providing & erecting 415V MCB Four Pole Switch for Lighting Load (B curve) having 10KA breaking capacity & confirms to IS :8828 in existing box having following capacity (a) 6 to 32 Amp. Cat.III	Ea.	3.00	581.65	Rupees Five Hundred Eighty One and Sixty Five Paise	1,744.95
160	Providing and erecting Approved make RCCBs conforming to IS: 12640 and having sensitivity of 30 mA and Short Circuit withstand capacity of 10 KA and suitable for operation on 3 phase and neutral 415V,50Hz. having characteristic of quick action & tripping with all advance feature & do not incorporate any electronic component for following Max. rating erected as directed. (ii) 40Amps. FP Cat.III	Ea.	3.00	2777.5	Rupees Two Thousand Seven Hundred Seventy Seven and Fifty Paise	8,332.50
161	Supply, laying, testing & commissioning 1.1 kV grade, XLPE insulated, stranded Aluminium conductor, galvanised steel flat strip / round wire armoured, extruded PVC type ST2 sheathed, heavy duty cable (to be laid on wall surface with necessary clamps / in existing cable trench / cable trays / conduit / pipe sleeves at road crossing or floor as per site requirement) conforming to IS:7098 (Part-1) & IEC:60502 (Part-1) of following sizes:	Rmt.	200.00	134	Rupees One Hundred Thirty Four Only	26,800.00

Sr. No.	Description	Unit	Quantity	Rate	Rate in Words	Amount (Rs.)
	a) 3.5 Core x 25 Sq.m.m					
162	Cable Terminals (Lugs) Providing & fitting crimping type Cable Terminals (Lugs) conforming to IS of following types and sizes Aluminium Tubular Terminals (Long Barrel) (in Sq. mm.) f) 25 Sq.m.m	Ea.	24.00	3.45	Rupees Three and Forty Five Paise	82.80
163	Providing & fitting heavy duty brass cable glands (nickel-plated) with washers & rubber ring conforming to IS, suitable for 3, 3½ & 4 core cables of following type & sizes: Double Compression Brass Cable Glands f) 25 Sq.m.m	Ea.	6.00	233.45	Rupees Two Hundred Thirty Three and Forty Five Paise	1,400.70

Sr. No.	Description	Unit	Quantity	Rate	Rate in Words	Amount (Rs.)
164	LV POWER CONTROL CENTER (PCC) Supply, installation, testing and commissioning LV Distribution Board (LVDB) totally enclosed, dust & vermin proof, indoor type, fabricated from CRCA sheet steel with minimum thickness of 3 mm for base frame / channel / gland plates, 2.0 mm for load bearing members / doors & 1.6 mm for internal partitions, minimum degree of protection - IP 52 as per IS: 2147, suitable for operation on 3-Phase, 4 Wire, 415 V, 50 Hz, Neutral effectively grounded, with instrumentation compartments accomodating meters, aux / protective relays, LED type indicating lamps & control MCBs as per IS: 13947, current & voltage transformers as per IS: 2705, air insulated electrolytic grade Aluminum / Copper bus bar for three phase & neutral system, GI earth bus for entire length, power / control wiring using 1100 V grade, FRLS insulated copper conductor wires conforming to IS: 694 & 8130, equipment fittings, horizontally running busbar compartment height of minimum 300 mm, incoming & outgoing cable connections for 1100 V grade, Aluminium / Copper conductor XLPE / PVC insulated & PVC sheathed armoured cable. LVDB shall have required incomming / bus coupler / outgoing modules of following type & ratings.Above 80 A, upto & including 250 A, 3 & 4 Pole, Air Break Fixed MCCB conforms to IS / IEC 60947-2 with trip free mechanism, current limiting type with Thermal-Magnetic /	Ea.	1.00	49660.45	Rupees Forty Nine Thousand Six Hundred Sixty and Forty Five Paise	49,660.45



Sr. No.	Description	Unit	Quantity	Rate	Rate in Words	Amount (Rs.)
	Microprocessor release (O / C, S / C & E / F) with adjustable settings & having minimum 2NO+2NC potential free auxiliary contacts with all necessary Electro-Mechanical protections & interlocks etc. MCCB module, when used as Incommer / Bus Coupler, shall have enclosure dimensions- 1800(H) x 600(W) x 600 (D) & following technical features: (1.13h) 4 Pole, MCCB with Breaking Capacity of Icu=50 KA at 415V (Ics =100% of Icu), Microprocessor release					
165	Cantilever Office Chair Non-revolving and non-tilting chair with armrest	No.	10.00	5075	Rupees Five Thousand Seventy Five Only	50,750.00
166	Revolving Chair with Center tilt mechanism Designed with 360 degree-revolving type	No.	5.00	6960	Rupees Six Thousand Nine Hundred Sixty Only	34,800.00

Sr. No.	Description	Unit	Quantity	Rate	Rate in Words	Amount (Rs.)
167	Executive Table with One side pedestal unit. Two legs with Gable end and modesty panel Width 1200 X Depth 600 X Height 750 (mm)	No.	3.00	15773	Rupees Fifteen Thousand Seven Hundred Seventy Three Only	47,319.00
168	Almirah Steel shelving cabinets conforming to BIS specification IS: 3312:2021 (with latest amendment). Width 910 X Depth 480 X Height 1830 (mm) for Storage	No.	2.00	19000	Rupees Nineteen Thousand Only	38,000.00
169	3 Seater Sofa With Leatherite Cover Length 1980 X Depth 775 X Height 800 (mm)	No.	1.00	19419	Rupees Nineteen Thousand Four Hundred Nineteen Only	19,419.00
170	RO & UV both ABS grade plastic Drinking Water Coolers with built in Water Purification System with storage capacity of 120 Liters. Purification Capacity of 15 Liter/ Hr and Cooling capacity of 50 Liter/ Hr.	No.	1.00	29000	Rupees Twenty Nine Thousand Only	29,000.00
<b>Total</b>						<b>2,83,33,059.00</b>

**Special Note:**

- Charges for the testing of material will be borne by Work Agency.
- Joint venture will not allowed.
- Bidder has to must submit all the filled up annexure and adequate detailed documents with technical bid/physical submissions for fulfilling qualifying criteria , failing witch BMC will disqualify the bidder without giving chance for submission of missing documents etc. for further clarifications.
- The quoted rates should be inclusive of all taxes , insurance, labor overhead charges, constructor's profit, royalties etc. except GST.
- GST will be paid extra as per prevailing rules in all running/final account bills.

**SUBMISSION OF PRICE PROPOSAL : I HAVE VISITED THE SITE OF WORK AND THOURGHLY GO THROUGH STATED SPECIFICATIONS AND CONDITIONS OF CONTRACT, HENCE , I AM SUBMITTING/QUOTTING RATE .....% ABOVE OR BELOW THEN ESTIMATED WORK AMOUNT Rs. 2,83,33,059.00 (Indian Rupees) .**

Signature of Contractor : Executive Engineer( Drainage)  
Name : Bhavnagar Municipal Corporation,  
  
Company's Seal : Bhavnagar  
  
Date : Date :

# BHAVNAGAR MUNICIPAL CORPORATION

## E-Tender Notice

**E-Tender Notice No. 15 BMC/DRAINAGE/AMRUT 2.0/tender/2024-25**



### Bid Documents For

**CONSTRUCTION OF STORE AREA FOR DRAINAGE DEPARTMENT, BMC AT  
F.P. NO. 66 UNDER T.P. SCHEME NO. 7 ADHEWADA, BHAVNAGAR**

**VOLUME –III  
DRAWINGS**

Milestone Dates	
Date of issue of placing tender document start date	As per tender volume I
Last date of Online Tender Submission	As per tender volume I
Last date of submission of physical Documents	As per tender volume I
Online Opening date of the Technical Bid (If convenient.)	As per tender volume I

**CLIENT: contact person  
Executive Engineer (Drainage Department),  
Bhavnagar Municipal Corporation.,  
Sir Mangalsinhji Road,  
Bhavnagar- 364 001**

**INDEX**

<b>Sr. No.</b>	<b>Drawing No.</b>	<b>Description</b>
1	<b>BMC/DSA/01</b>	LAYOUT PLAN FOR STORE AREA OF DRAINAGE DEPARTMENT (FP NO. 66)
2	<b>BMC/DSA/02</b>	LAYOUT PLAN FOR STORE AREA OF DRAINAGE DEPARTMENT (FP NO. 66) (LANDSCAPING)
3	<b>BMC/DSA/03</b>	TYPICAL DETAILS OF COMPOUND WALL
4	<b>BMC/DSA/04</b>	TYPICAL DETAILS OF ENTRY GATE
5	<b>BMC/DSA/05</b>	TYPICAL DETAILS OF EXIT GATE
6	<b>BMC/DSA/06</b>	DETAILS OF OFFICE BUILDING
7	<b>BMC/DSA/07</b>	FURNITURE LAYOUT PLAN OF OFFICE BUILDING
8	<b>BMC/DSA/08</b>	DETAILS OF WAREHOUSE
9	<b>BMC/DSA/09</b>	DETAILS OF STOREKEEPER OFFICE, COMMON TOILET & HANDICAP TOILET
10	<b>BMC/DSA/10</b>	FURNITURE LAYOUT PLAN OF STOREKEEPER OFFICE
11	<b>BMC/DSA/11</b>	DETAILS OF MAINTENANCE AREA
12	<b>BMC/DSA/12</b>	DETAILS OF PARKING SHED AREA FOR CAR & TWO WHEELER VEHICLES
13	<b>BMC/DSA/13</b>	DETAILS OF PARKING SHED FOR TRUCK
14	<b>BMC/DSA/14</b>	DETAILS OF PARKING SHED FOR DG SET TRAILER
15	<b>BMC/DSA/15</b>	DETAILS OF UG TANK
16	<b>BMC/DSA/16</b>	FLOORING DETAILS FOR MAINTENANCE AREA
17	<b>BMC/DSA/17</b>	FLOORING DETAILS FOR STOREKEEPER AREA, COMMON TOILET, HANDICAP TOILET AND RAMP
18	<b>BMC/DSA/18</b>	TYPICAL CROSS SECTION OF CEMENT CONCRETE ROAD
19	<b>BMC/DSA/19</b>	TYPICAL CROSS SECTION OF PAVER BLOCK
20	<b>BMC/DSA/20</b>	PROPOSED SEWERAGE NETWORK AND WATER SUPPLY NETWORK
21	<b>BMC/DSA/21</b>	TYPICAL DETAIL OF INCEPTION CHAMBER
22	<b>BMC/DSA/22</b>	TYPICAL DETAIL OF MANHOLES

**MUNICIPAL CORPORATION**

**BHAVNAGAR**

**VENDOR LIST**

**(A) LIST OF APPROVED VENDORS FOR CIVIL WORKS**

<b>Sr. No.</b>	<b>ITEMS</b>	<b>Approved Brands / Quality</b>
1	CEMENT PPC 53 Grade & SULPHATE RESISTANT CEMENT,S.R.C.	Ambuja, Hathi, Ultra Tech, Sanghi, Siddhi, Hi-bond Kamal
2	BRICKS	MBM, Arjun, PBM, 555, Kisan, ABM, TRD, Paresh, Dhara, B.R.C., Kiran, BMB, Kirit, Sonal
3	Steel TMT, CRS	TISCO, SAIL, VIZAG, Kamdhenu, NATIONAL, Electrotherm, JSW, Welspun steel, Pollad Steel, DIAMOUND TMT, M. G. Steel, Friends Steel, Crown next TMT, Briskon TMT, GERMAN TMX
4	VITRIFIED TILES	Asian, Kajaria, Jonson, Varmora, Simpolo, OASIS
5	CERAMIC TILES	Asian, Kajaria, Johnson, Varmora, Simpolo, OASIS
6	GLAZED TILES	Asian, Kajaria, Johnson, Varmora, Simpolo
7	ACRYLIC PAINT	ICI, Asian, Nerolac, Burger
8	OIL BOUND DISTEMPER	ICI, Asian, Nerolac, Burger
9	EXTERIOR WEATHER PROOF EMULSION PAINT	ICI, Asian, Nerolac, Burger
10	Oil Paint	ICI, Asian, Nerolac, Burger
11	SANITARY WARE	Cera, Hindware, Parryware
12	CAST IRON PIPES AND FITTINGS.	NECO, Swayarhoo, Bengal, Oriental Castings, Electro steel Castings
13	P.V.C. PIPES AND FITTING (UPVC/CPVC)	Finolex, Supreme, Jain, Kisan, Astral, Dutron, Prince
14	CHROMIUM PLATED WATER SUPPLY FITTINGS	Jaquar, Ess Ess, Plumber ,ESSCO, Crown, Metro, Prince
15	GALVANIZED PIPE	Tata, Essco, Jaquar, Ess Ess, Plumber
16	GALVANIZED FITTINGS	'R' Brand, 'RV' Brand, Kranti
17	C.I. MANHOLE COVER	Manish, Sil, NECO
18	PLUMBING FIXTURES	Jaguar, Plumber, Essco
19	PVC WATER TANK (100% VIRGIN PVC)	Sintex, Aqua
20	ALUMINIUM SHEETS AND ACCESSORIES	Nalco, Jindal, Hindalco, Banko

Sr. No.	ITEMS	Approved Brands / Quality
21	ALUMINIUM EXTRUDED DOOR/ WINDOW SECTION	Jindal, Hindalco, Banko, Ajin India, Aldowin, Alumilite
22	ALUMINIUM HARDWARE	Rajdoot, Belu, Diamond, Glider, Ajin India, Aldowin, Alumilite
23	WATER PROOFING MATERIALS	Zycosil, Dr. Fixit, Kerakoll, Pidilite, Roff
24	DOOR CLOSER	Efficient Gadget, Everite, Hardwin, Aldowin, Ozone
25	DOOR FITTINGS	Godrej, Efficient Gadgets (E.G.) Dunex, Doorset, Suzu, Coral
26	HINGES	Suzu, Yama, E.P.P.W.
27	SCREW AND BOLTS	Nettle Folds, GKW, Stud
28	BOLTS & FASTENERS	Hilti, Fisher
29	LIFT	Top, Express, Omega, OTIS, Schander, TRIO, Aegis Elevator, Mitsubishi, Aditya, Siemens slider
30	ROOFING MATERIAL – Galvalume sheets	TATA, Essar, Jindal
31	Slag Cement	SANGHI CEMENT Sanghipuram
32	CPVC PIPES FOR AUTOMATIC SPRINKLER FIRE EXTINGUISHING SYSTEM	ASTRAL POLY TECHNIK LIMITED પાર્કિંગ એરિયા, બેઈઝમેન્ટ એરિયા જેવા વિસ્તારો સિવાય માત્ર કન્સ્ટ્રીક્ટ પાઈપીંગ માટે આ કંપનીના CPVC pipe નો ઉપયોગ fire sprinkler piping માટે કરવાની મંજૂરી આપવામાં આવે છે.
33	AAC Blocks	NXTBLOC
34	Jointing Mortar	NXTFIX Block
35	Ready Mix Plaster	NXTPLAST
36	Block joining Masonry Mortar	Unifix
37	Tile adhesive	Unifix
38	RCC bench	Sardar Pre cast
39	Rubber mould garden curbin	Sardar Pre cast



<b>Sr. No.</b>	<b>ITEMS</b>	<b>Approved Brands / Quality</b>
40	Rubber mould Paver block	Sardar Pre cast
41	Fencing Pole	Sardar Pre cast
42	RCC Masonry block	Sardar Pre cast
43	Pre cast wall	Sardar Pre cast

**(B) LIST OF APPROVED VENDORS FOR MECHANICAL & ELECTRICAL WORKS**

Sr. No.	Description	Name of Manufacturer
1	HSCF Pump	Crompton Greaves Ltd
		Kirloskar Brothers Limited (KBL)
		JASCO
		Mather & Platt Pumps Ltd.
		Jyoti Ltd.
2	Electric Motor	Lubi Industries LLP
		Bharat Bijlee Ltd.
		Jyoti Ltd.
		JSL Industries Ltd.
		Jeumont Electrical India Pvt. Ltd.
		LHP
3	Electrical Panel	Crompton Greaves Ltd
		Bhagyashree Power Control
		Dynamic Control System
		Elembica Services
		JSL Industries Ltd.
		Nutral Power Tech
4	Kinetic Air Valve	Kirloskar Brothers Limited (KBL)
		FOURESS Engineering (India) Limited.
		Durga Valves Pvt.Ltd
		Orbinox
		श्री. डिवा. एन्ड.सु.टी.स
5	Expansion Bellows	Precise Engineers
6	Dewatering (Drain) Pump(Submersible/ Horizontal)	KSB Pumps
		Kirloskar Brothers Limited (KBL)
		JASCO
		Crompton Greaves Ltd
		La Gajjar Machinery Pvt Ltd.
		Pullen Pumps Industries Pvt. Ltd.
		MBH
7	Sluice Valves and Sluice Gate	Kirloskar Brothers Limited (KBL)
		DURGA Valves Pvt.Ltd
		L & T Valves
		Jupiter
		SACHDEVA
8	UPVC Pipe	Supreme Industries Ltd.,Mumbai
		Dutron Polymers Ltd
		Parixit Industries Ltd., A'bad
		Jain Irrigation Systems Ltd., Jalgaon
9	HDPE Pipe	Parixit Industries Ltd., A'bad
		Jain Irrigation Systems Ltd., Jalgaon
		Dutron Polymers Ltd
		Jindal
10	C.I. Pipe	Essar Steel
		Electro Steel, Kejrival, Oriental Castings, BIC, Jindal, Lanco Industries Ltd.,Chennai, Kesins
13	EOT Crane	Grip Engineering Pvt. Ltd., JAPS Project, Brady & Morris Engineering Co. Ltd., Techno Industries

Sr. No.	Description	Name of Manufacturer
14	Cable & Wires	KEI Industries Ltd.
		Polycab Wires Pvt. Ltd.
		Aerolex Cables Pvt. Ltd.
		Allwin Industries
		Finolex Cables
		L&T Cables
		ULTRA CAB (India) Limited
15	Transformer	Atlanta Electricals Pvt. Ltd.
		Powerlite Electricals
		Voltamp Transformers Ltd.
		SKP Transformers
		Arya Electronics
16	Components for MCC :	
	Switch	L&T, Siemens
	HRC Fuse	L&T, Siemens
	Timer	L&T, Siemens
	Relay	L&T, Siemens
	Push Button Stations	L&T, Siemens
	Indicating Lamp	L&T, Siemens
	Cable Jointing Kit	CCI, M. Seal
	MCB/DB's	MDS, Siemens, Indokupp
17	Capacitors	L&T, Crompton, Khatau Note: Capacitors shall be oil fill type
18	KWH Meter	Simco, Jaipur, GEC
19	Light Fittings: (Indoor & Outdoor Luminaries)	Philips, Crompton, Bajaj, NESSA Illumination MEMIGHTY
20	Exhaust Fans	Crompton, Bajaj,
21	Ceiling Fans	Crompton, Bajaj, Havells
22	Air Blowers	Everest Ltd.
		Swan Pneumatics (P) Ltd
23	Alum Dosing Pumps	Asia LMI
		VK Pumps
		Swelore
24	Pressure Gauges	General Instruments
		Bells Control
		H. Guru Marketing
25	Level Gauge / Indicator	R K Dutt
		Levecon
		S. B. Electromec
26	Clarifier Equipment	Enviro Control Associates
		Voltas Ltd
		Hindustan Dorr-Oliver
		Geomiller/Triveni
27	Chlorination System	Industrial Device (I) Pvt. Ltd
		Metito
		Chloroequip
		Pennwalt
28	Gear Box	Greaves
		Radicon
		Elecon
		Shanti

Sr. No.	Description	Name of Manufacturer
29	Level Switches	Level-Tech
		Revathi Electronics
		Levec
30	Refrigerator	LG, Samsung, Kelvinator
31	PVC Pipes for Fluid	Finolex, Jain Irrigation
32	PVC Conduits for Electricals	Precision, Shakti
33	Butterfly Valve	KIRLOSKAR Brothers Limited(KBL), DURGA valves Pvt Ltd, L & T valves, R&D MULTIPLE, Jupiter, श्री कृष्णा इंटरवैल्व IVC, IVI, Audco, R & D multiple, Jupiter, Cair, Orbit Engineers
34	Check Valve (Dual Plate check Valve)	KIRLOSKAR Brothers Limited(KBL), DURGA valves Pvt Ltd, Orbinox, R&D MULTIPLE, Orbit Engineers
35	Metallic Expansion Bellow	Beloflex(B.D. Engineers), Stanfab Engineering Pvt. Ltd., D. Wren Engineering Pvt. Ltd., Sur Industries,
36	Centrifugal / Centrifugal Non Clog Pumps	Beacon Weir, KSB, Mather & Platt (Wilo), Worthington, WPIL, Xylem pumps , Grundfos Pumps Pvt. Ltd., MBH, JASCO
37	Submersible non Clog Pumps / Submersible Centrifugal Pumps	Kirlosker, KSB, ABS, ITT- Flyght, Xylem pumps, Grundfos Pumps Pvt. Ltd. , MBH, JASCO, AQUA, Jyoti, PULLEN PUMPS, Alpha, Het Pump
38	Screw Pump	Roto, Netzsch, Tushaco, Seepex
39	Metering / Dosing Pumps	Swelore, V.K. Pumps, Shapotools
40	Non Return Valves ( Single / multi door) / Dual Plate Check Valves	Kirlosker, IVC, IVI, R & D multiple, Durga, Jupiter, Cair, Orbit Engineers
41	Knife Gate valves	Jash, Fouess, Vass (Dezurick), Vag, Orbinox, Orbit Engineers
42	Sluice gates / open Chanel Gates	Jash Engineering, IVC, R & D Multiple, Jupiter
43	Mechanical Fine Screens – Step (Mat) Type / Drum Type	Jash, Huber, Johnson, Savi, Italy, Apollo Screens
44	Mechanical Course bar Screen	Jash, Huber, Johnson, HDO, Triveni, Savi, Italy
45	Manual Bar Screen	Jash, Japs, HDO, Triveni, Auric
46	Grit mechanism	EIMCO – KCP, Hindustan Dorr – Oliver, Jash-Shivpad, Triveni, Voltas
47	Diffused Aeration System	EDI, OTT, Rehau
48	Air Blower	Kay, Swam, Everest, Usha Compressors, Gardner Denver
49	Agitator / mixer	Remi, Schurtek, Fibre & Fibre, Milton Roy
50	Gear Boxes	Greaves, Elecon, CPEC, PEPL, Bonfiglioli
51	Centrifuge	Humboldt, Alpha Laval, Hiller

<b>Sr. No.</b>	<b>Description</b>	<b>Name of Manufacturer</b>
52	HDPE Pipes	Astral, Dutron, Duraline, Narmada, RIL (PIL), Penwalt, Anjney, Jain Irrigation, Sangir
53	Air Compressor	Ingersoll – Rand, Khosla, Kirlosker, CPE, Alpha
54	Bearing For All Equipments	SKF, FAG, Tata
55	Fasteners	Precision, Durakhanawala, Echjay, Tata, Sundaram
56	Mechanical Seals	Eagle Seals (Sealol), Durametallic, Burgman
57	Electric Actuator	Auma, Rotork, Emerson, Pentair
58	(1) CATEGORY III Indoor LED fittings, LED Panel light, LED down light, outdoor LED light (street light, LED flood light, LED Post top lantern, LED bollard ) (2) Solar LED Light	NESSA ILLUMINATION TECHNOLOGIES PVT.LTD., Litsun, Nextray
59	STREET LIGHT POLES	AMBICA POLES (for octagonal poles, swage poles, street light poles, high mast poles, decorative poles, conical poles, JETCOTECH Engineering LLP
60	Resilient Seated Slice Valve	Cair
61	Air Valve	Cair, Orbit Engineers
62	Flow Control valve	Cair
63	Altitude Control valve	Cair, Orbit Engineers
64	Pressure reducing valve	Orbit Engineers
65	Pressure relief valve	Orbit Engineers
66	Ball valve	Orbit Engineers
67	Mast pole	JETCOTECH Engineering LLP
68	Earthing material	JETCOTECH Engineering LLP
69	Hot dip galvanizing	JETCOTECH Engineering LLP
70	LED Highbay	Litsun

**(C) LIST OF APPROVED VENDOR FOR INSTRUMENTATION SYSTEM**

<b>SR NO</b>	<b>DESCRIPTION</b>	<b>Name Of Manufacturer</b>
1	Electromagnetic Flow Meter	E+H, Siemens, Abb, Fuji, Yokogawa, Krohne-Marshall, AAROHI Embedded System Pvt Ltd., Emerson, SBEM
2	Pressure Gauges	Wika, H.Guru, General Instruments Consortium Manometer (India) P. Ltd. , Baumer, Waaree
3	Pressure Switch	Danfoss , Indfoss , Switzer
4	Process Analyzers (pH, DO, Free / Residual Chlorine , BOD / COD)	E+H , Emerson , Hach , Chemitech , Polymetron, Wtw (Forbes Marshall),Yokogawa
5	Ultrasonic transmitter level / diff. level / flow	E+H, Siemens – Milltronics, Krohne, Vega
6	Hydraulic level transmitter	E+H,Siemens, ABB, Forbes- Marshall, Emerson, SBEM
7	Displacer/Float Switches	Levcon, Nivo, Toshbro, Pune Techtrol , SBEM
8	PP Float / Buoyancy switch	Pepprl + Fuchs, Baumer, Waaree, E+H , Pune Techtrol , SBEM
9	Float & Board Type Level Gauge	Levcon, Nivo, Toshbro, Pune Techtrol, SBEM
10	Electromagnetic Flow Meter	E+H, Siemens, ABB, Fuji, Yokogawa, Krohne-Marshall
11	Field Transmitter (P, DP,F, L , T)	ABB, Fuji, Yokogawa, Honeywell, Emerson
12	Pressure Gauges	Wika, H.Guru, General Instruments Consortium Manometer (India) P. Ltd., Baumer, Waaree
13	Panel Mounted Process Indicator & Flow Integrator	Masibus, Nishko, Nivam, Selectron, Radix, Yokogawa, ABB
14	Pressure Switch	Danfoss, Indfoss, Switzer
15	Programmable Logic Controllers	Rockwell (Allen Bradeley), Siemens, Schneider, Fuji, ABB, GE Fanuc
16	Control Panel Enclosure	Rittal, Enklotek, Bartakke, BCH, Eldon
17	Alarm Annunciator	Aplab Ltd., Minilec , IIC
18	Solenoid valves	Asco, Rotex, Schrader
19	Tube Fitting	Excel Hydropneumatic, Multimetal, Placka

20	Instrument Valves , Manifolds	Aptek, Anmol (Superlok), Excel Hydropneumatic, General
21	Fitting	Instrument Consortium , Multimetal, Technomatic, Placka
22	Pneum , Brass Fitting	Swagelok, Multimetal Industries, SMC, Festo
23	Control Panel Accessories / Components	
a.	Miniature Relay	Wago, Omron,Phoenix, Rockwell
b.	Indication Pilot Lamps (LED Type)	Teknic, Schneider, Siemens
c.	Push Button / Selector Switch (with NO/NC Elements)	Teknic, Schneider, Siemens
d.	DC Power Supplies (DIN Rail mounted)	Phoenix, Omron, Schneider, Rockwell
e.	Terminals	Elmex, Phoenix, Wago, Connectwell
f.	Panel Wires	Finolex , Havell's , R R Kabel
g.	Panel Illumination	Philips , Crompton , GE
24	Instrument Cables (Power , Signal , Control)	Associated Cables, Associated Flexible and Wires P.Ltd., Brooks Cables, Thermo Cables, Udey Pyro
25	Cable Glands	Ex- protecta, Braco, Sudhir, Comet, Connectwell
26	Junction Box	Ex- protecta, CEAG, Sudhir, Baliga, FCG
27	Cable Tray	M.M.Engineering, Globe, Jacinth, Equi. Reputed, JETCOTECH Engineering LLP
28	Computer System	HP-Compaq, Dell, IBM, Sony, Samsung
29	UPS	Hirel-Hitachi, Emerson, APC
30	<ol style="list-style-type: none"> <li>1. PLC (Programmable Logic Controller )</li> <li>2. SCADA (Supervisory Control and Data acquisition )</li> <li>3. VFD (Variable Frequency Drive Up to 500 KW )</li> <li>4. ACB ( Air Circuit Breaker up to</li> </ol>	MITSUBISHI ELECTRIC INDIA PRIVATE LIMITED, Emerald House, EL-3, J Block, M.I.D.C., Bhosari, Pune 411026

	<p>6000A)</p> <ol style="list-style-type: none"><li>5. MCCB ( Moulded Case Circuit Breaker up to – 1600 A)</li><li>6. MCB (Miniature Circuit Breaker up to – 63 A)</li><li>7. ELCB (Earth Leakage Moulded Case Circuit Breaker up to 1600 A)</li><li>8. Contractor up to – 800 A &amp; OLR (Over load Relay) up to 630 A</li><li>9. Multi Functional Meters</li><li>10. MPCB (Motor Protection Circuit Breaker up to 32 A )</li></ol>	
--	---	--



**(D) LIST OF APPROVED VENDORS FOR MATERIALS RELATED TO WATER  
SUPPLY AND SEWERAGE NETWORK**

<b>SR. NO.</b>	<b>ITEMS</b>	<b>NAME OF AGENCIES</b>
1	A C Pressure pipe MAZZA process	Lotus, Kirti
2	A C Pressure pipe MEGHNANI process	Lotus, Kirti, Hindustan
3	Sluice Valve	Durga, kartar, Kirloskar, Jupiter, SACHDEVA ( C.I. & D.I.), શ્રી ક્રિષ્ના ઈન્ડસ્ટ્રીઝ, Cair, Orbit Engineers
4	DI Pipe	Electrotherm (I) Ltd.,Ahmedabad, Lanco Industries Ltd.,Chennai, Electrsteel, Jindal Saw Ltd.,Ahmedabad, Kesins, Welspun
5	R.C.C. PIPE ( COLLAR JOINT & SOCKET SPIGOT JOINT) CLASS NP3 & NP4, & R.C.C. COLLARS	VIPUL SPUN PIPES (SIHOR & LATHIDAD,BOTAD), KATARIYA & CO. (DHASSA), OMKARESHVAR PIPES ( NAVAGAAM), OMKAR PIPES ( LATHIDAD, BOTAD), MARUTI PIPES ( BAGODARA ,AHMEDABAD), KALATHIYA PIPES(BAGODARA ,AHMEDABAD), R. S. PIPES (BODELI), UMA HUME PIPES (KALOL, GANDHINAGAR), SIDHDHIVINAYAK ( KARDEJ ,BHAVNAGAR)
6	R.C.C. MACHINEOLE FRAME & COVER, INLET FRAME COVER 10T.(600*450 MM.) , 20T.,35T., & 50T.	SONI CEMENT PRODUCT , VIPUL SPUN PIPES, KATARIYA & CO., OMKARESHVAR PIPES, OMKAR PIPES, MARUTI PIPES, KALATHIYA PIPES , R. S. PIPES, UMA HUME PIPES, SIDHDHIVINAYAK , S.K. Corporation, Laxmi Price Industries, S.J.Corporation, Sardar pre cast
7	Stone ware PipeManufacturer having BIS Certificate for ISI marking	Krishna Pipe, j.K. Pipe, Taya ceramic, Burn & co., perfect Potteries, Navroji Vakil, Kashmira
8	D.I. & C.I. FITTINGS	RG BRAND, ESSEM Engineering Industries, Bikaners Engineers works
9	CID Joints	ESSEM Engineering Industries
10	Valves & Graded Castings	ESSEM Engineering Industries
11	Pipe Fittings	ESSEM Engineering Industries, Bikaners Engineers works
12	CI/DI/MS graded castings	Bikaners Engineers works
13	Scaper machine hole	Sardar Pre cast



# DETAILS OF OFFICE BUILDING

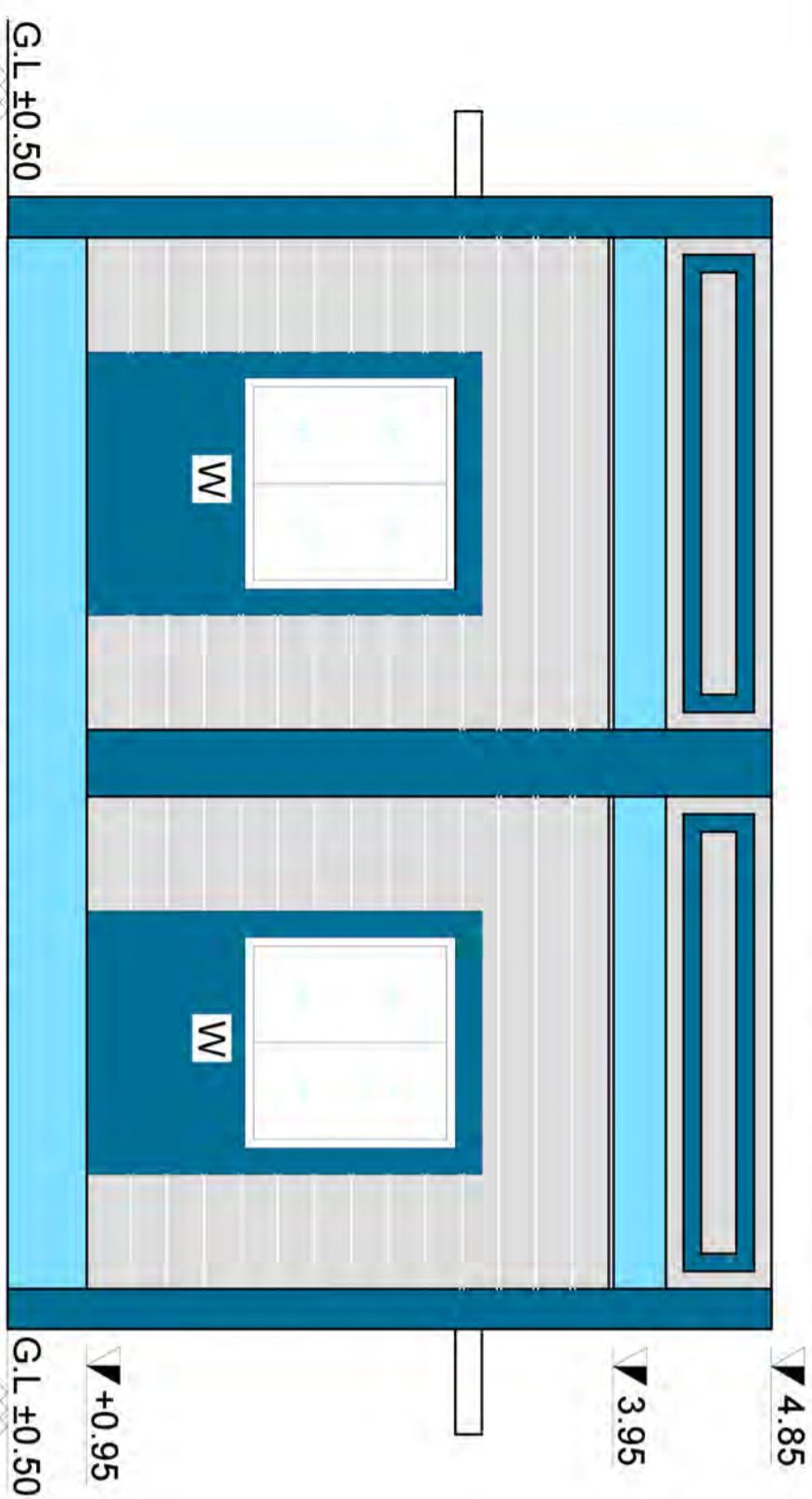

ELEVATION

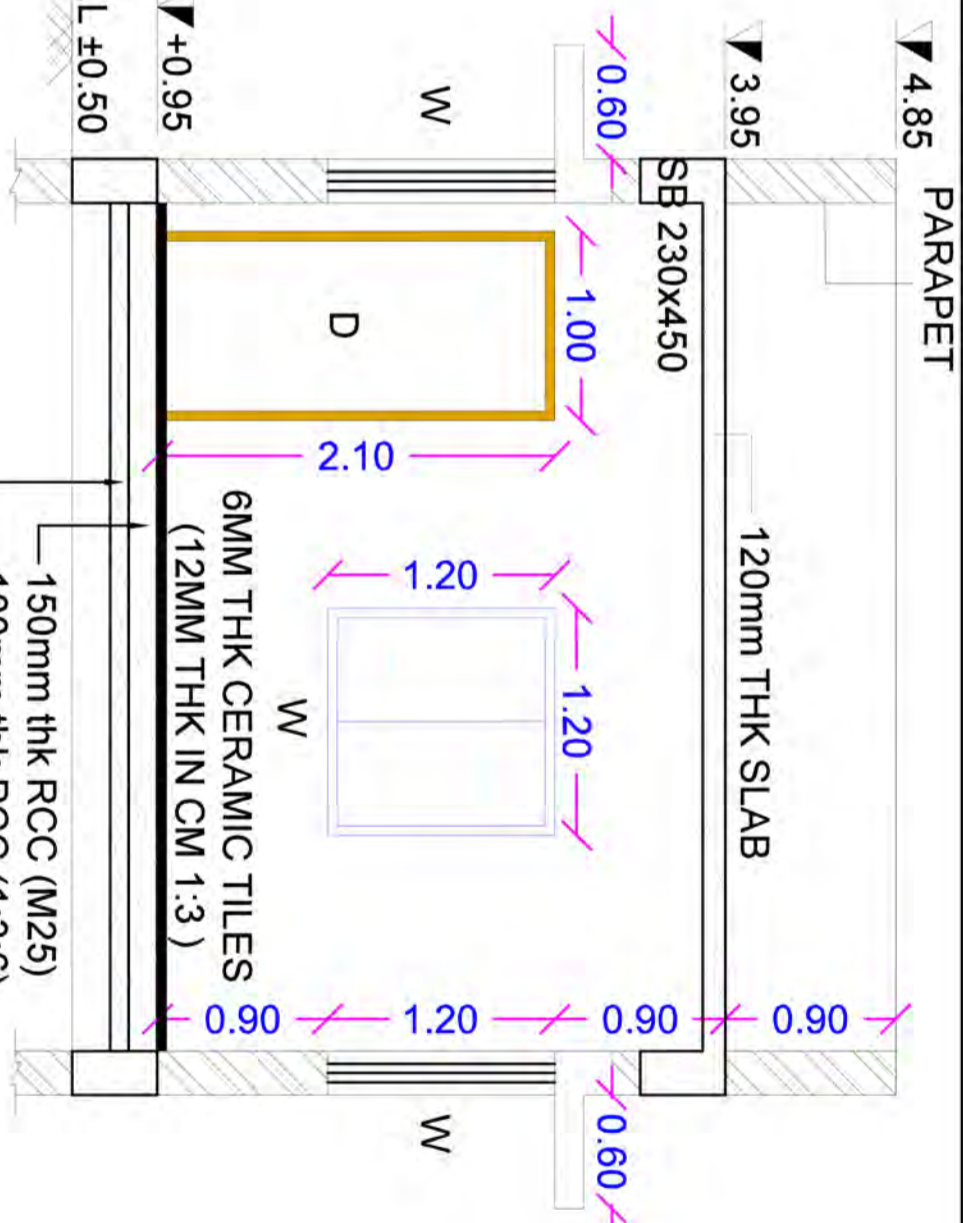

SEC B-B

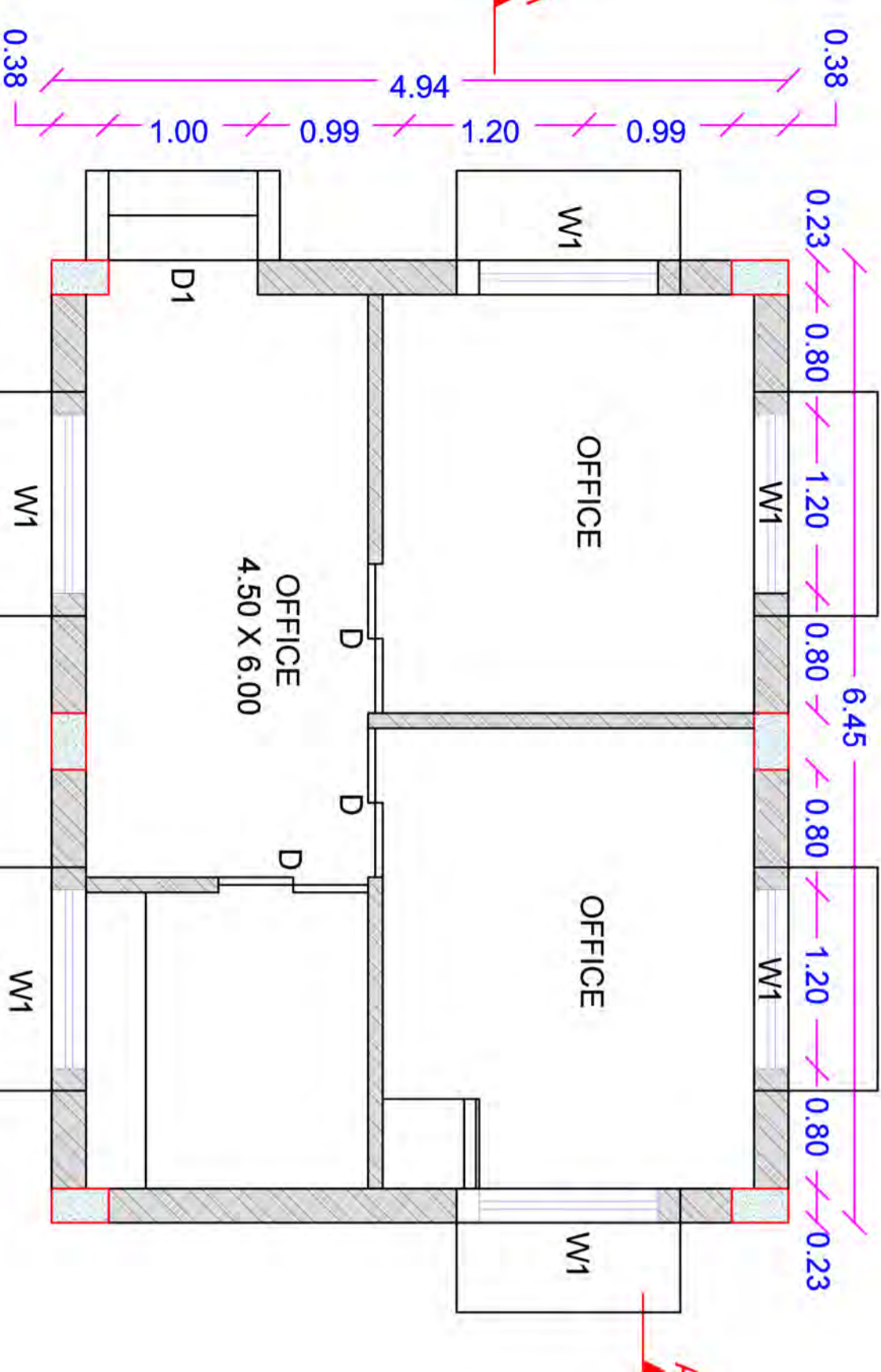

OFFICE BUILDING

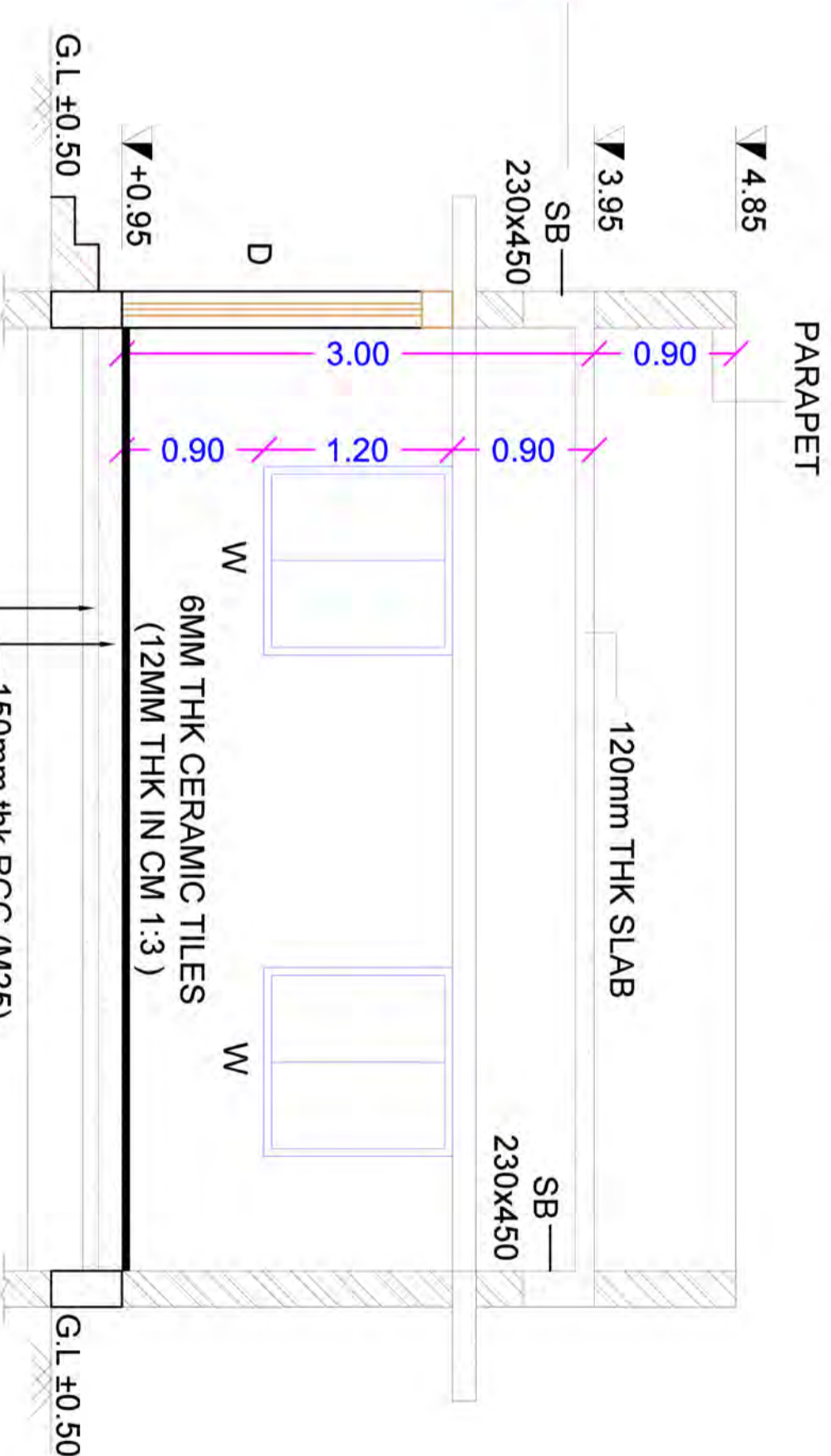

SEC A-A

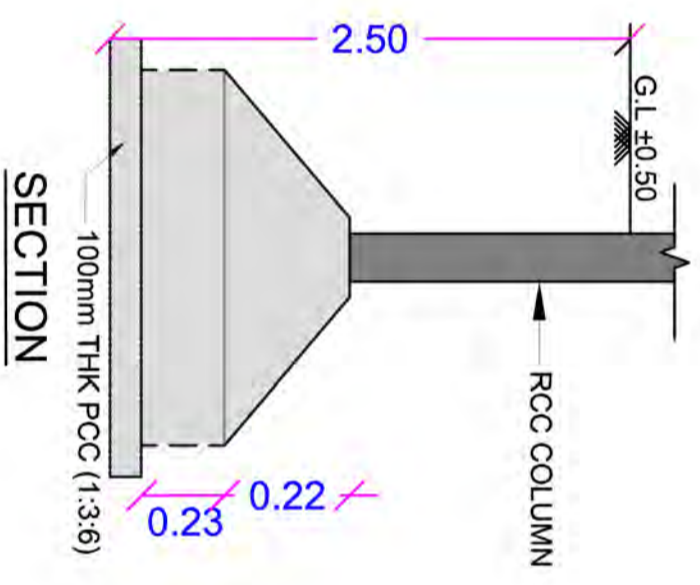

SECTION

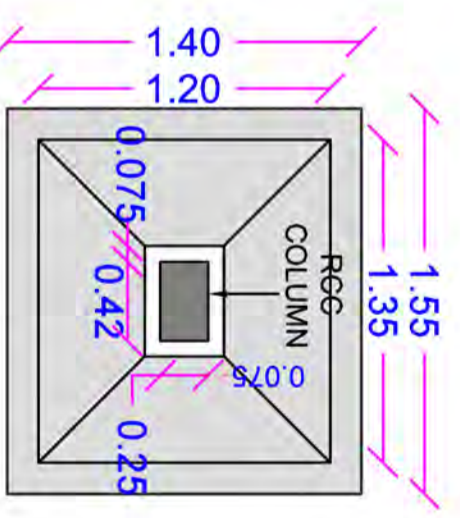

DETAILS OF FOOTING

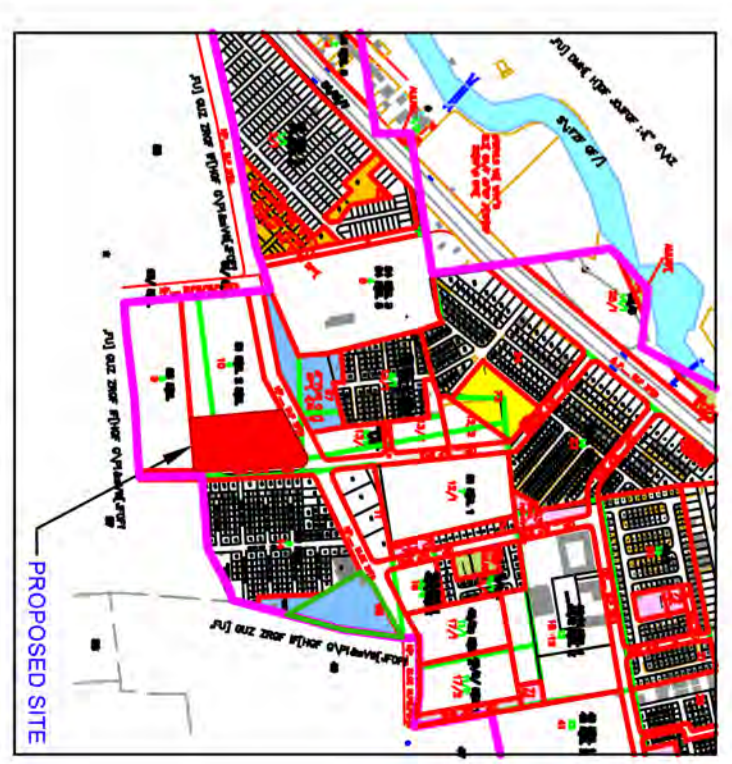

KEY PLAN

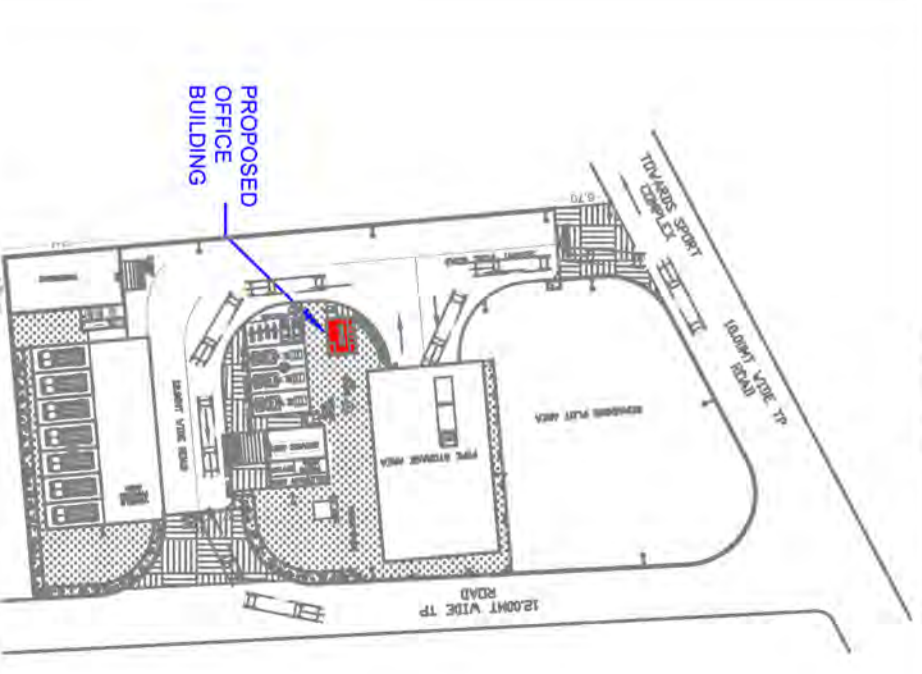

LAYOUT PLAN

## SCHEDULE OF OPENINGS

MARK	SIZE	HIGHT OF SILL	NOS.
D	1000 x 2100		2
W	1200 x 1500	900	4

## TENDER DRAWING

NO	DATE	DESCRIPTION	SIGNATURE
PROJECT:- CONSULTANCY SERVICE FOR PREPARATION OF DPR, DTP AND PMC SERVICE OF SEWERAGE PROJECT UNDER AMRUT 2.0 OF BHAYNAGAR CITY.			
CLIENT:- THE EXECUTIVE ENGINEER, DRAINAGE DEPARTMENT, MUNICIPAL CORPORATION, CENTRAL OFFICE BUILDING, SIR MANGALSINHJI ROAD, BHAYNAGAR-364001			
CONSULTANT:- FACILE MAVEN PRIVATE LIMITED 1701, 2 & 3, Rio Empire, Ph: + 91 - 261 - 6575998 Opp. Pal RTTO, Pal, Surat - Fax: + 91 - 261 - 2733584 395009 Email: info@facilemaven.com			
DRAWN BY :- AKSHAY			
DESIGNED BY :- PURVA			
CHECKED BY :- A.K. GARG			
SCALE :- N.T.S			
DRG. NO. :- BMC/DSA/06			
DATE :- 18/11/2024			
REVISION :- RO			

TITLE:- TYPICAL DETAILS OF OFFICE BUILDING



# FURNITURE LAYOUT PLAN OF OFFICE BUILDING

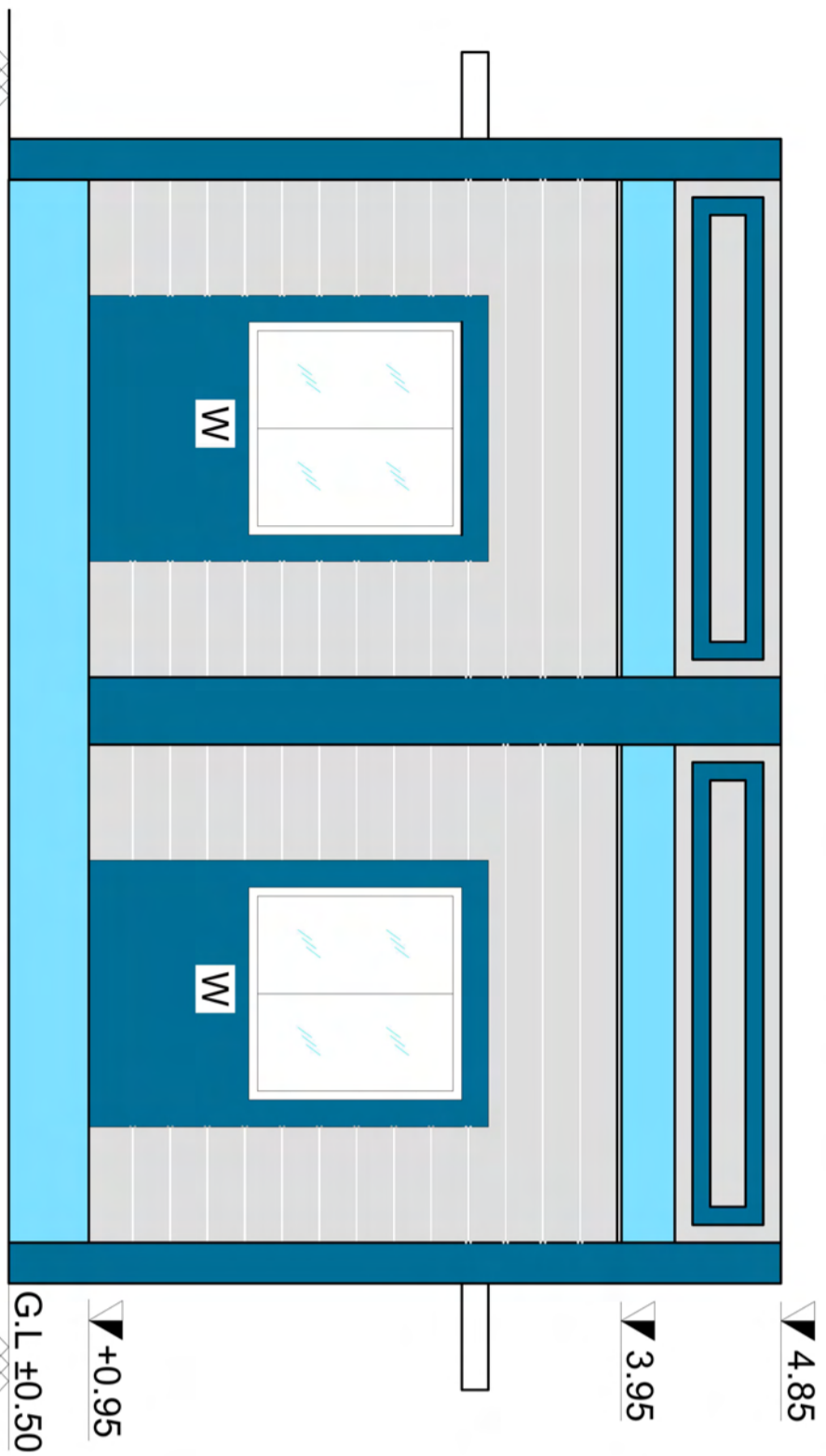

ELEVATION

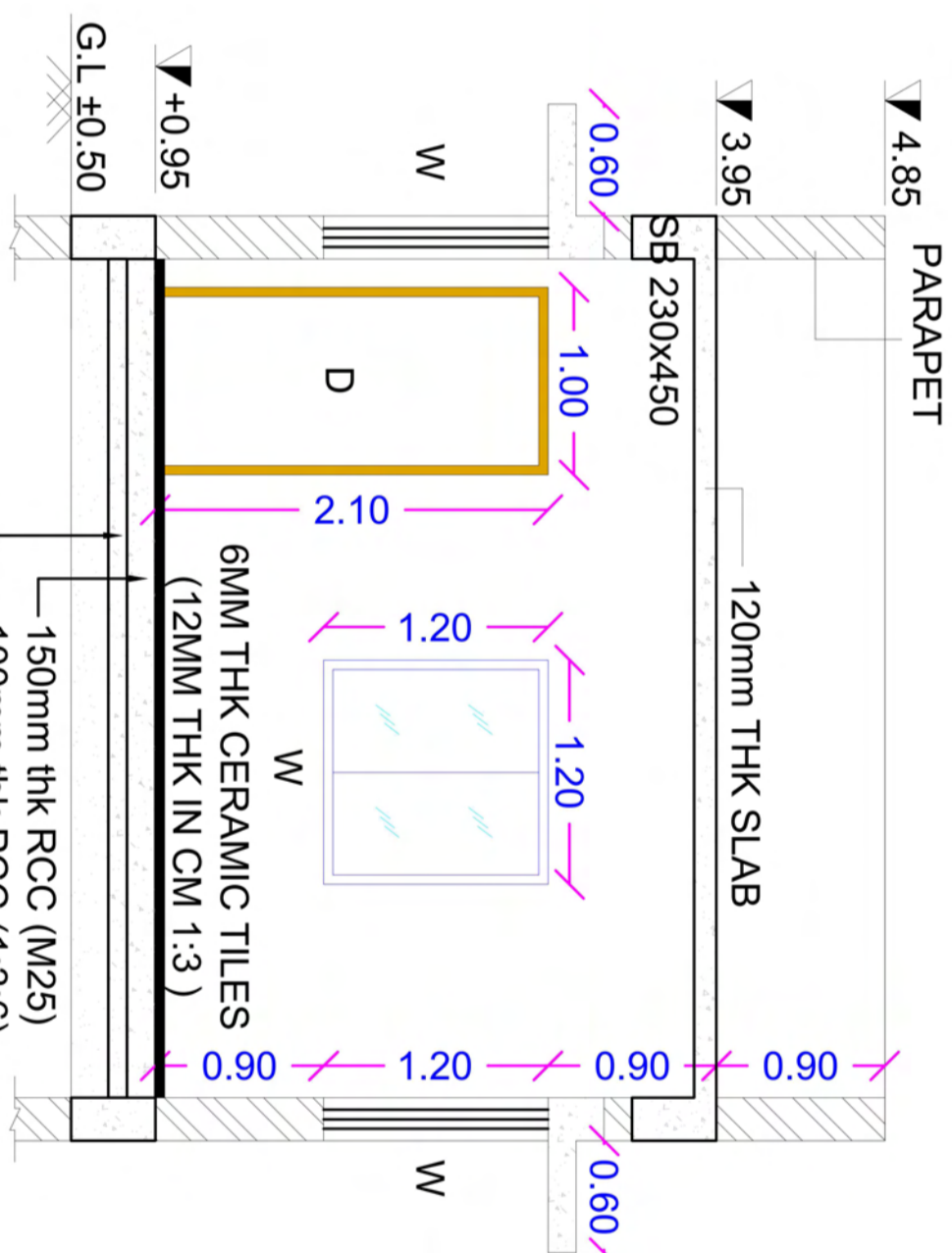

SEC A-A

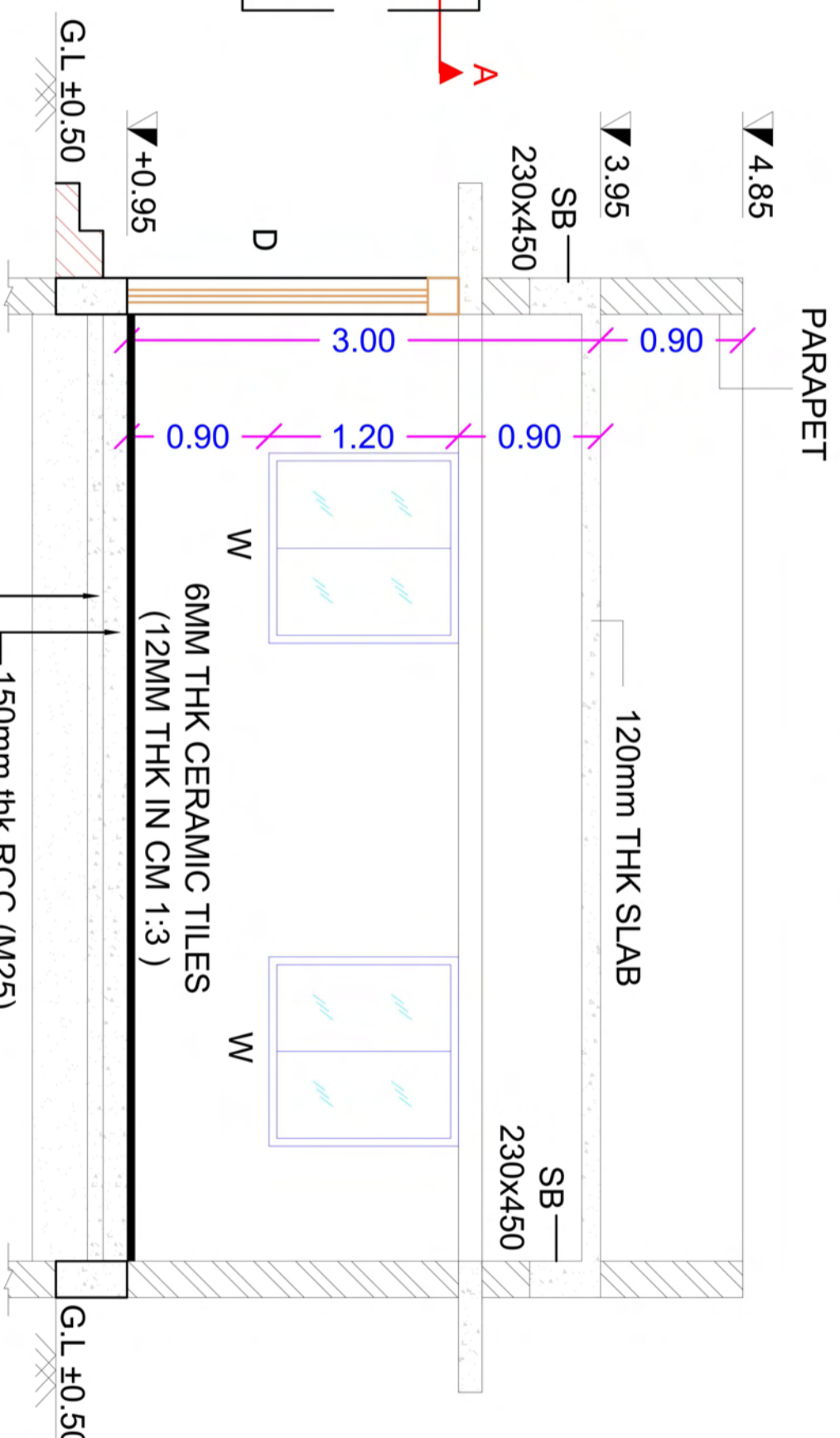

SEC B-B

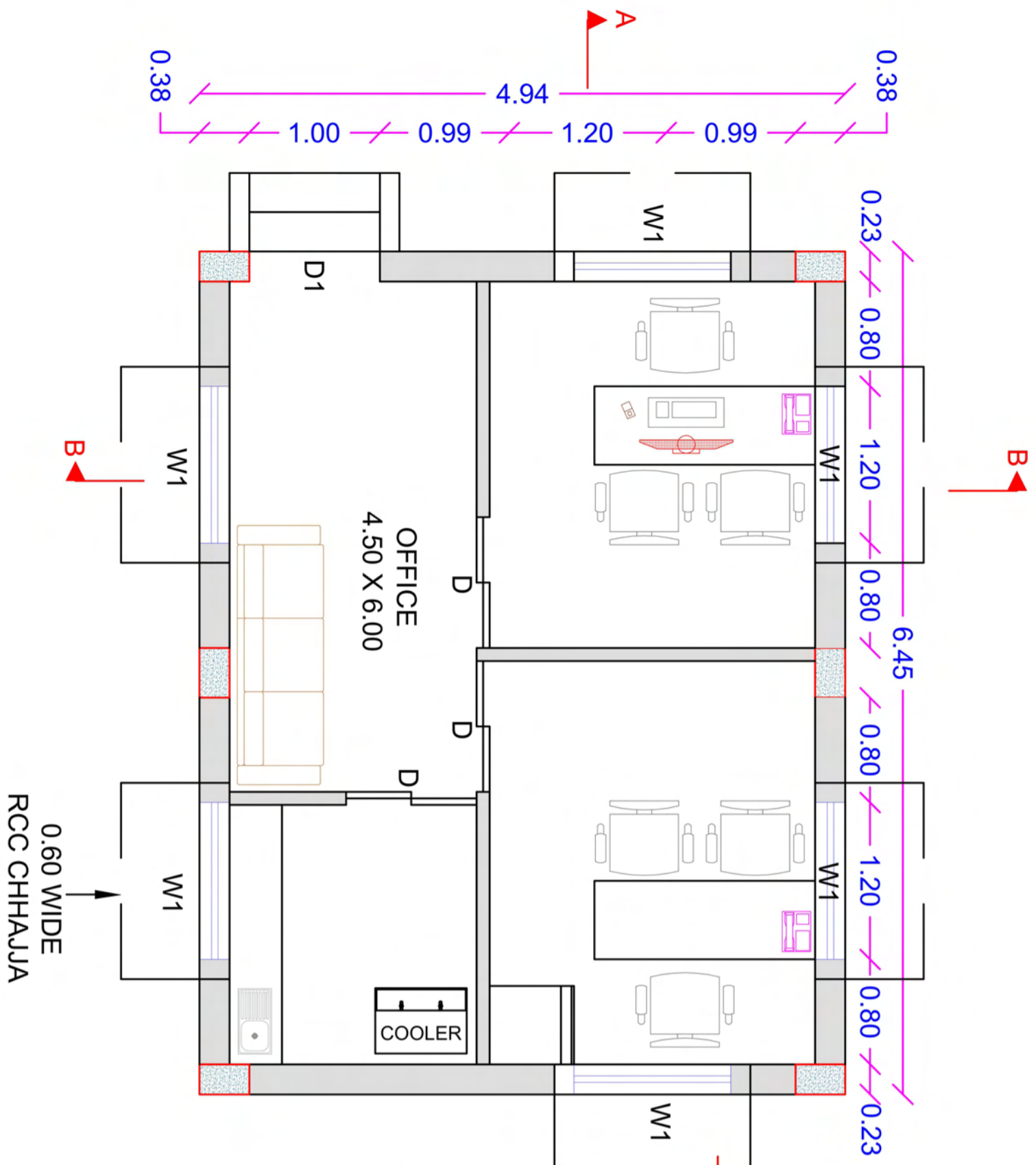

OFFICE BUILDING

0.60 WIDE  
RCC CHHAJJA

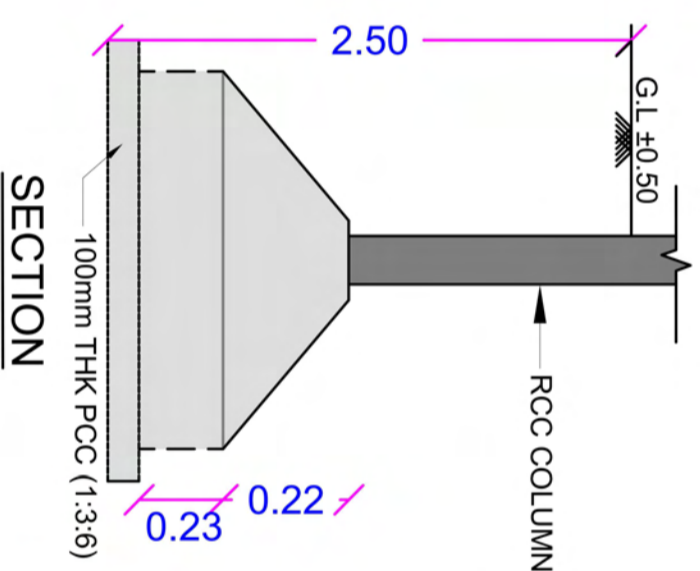

SECTION

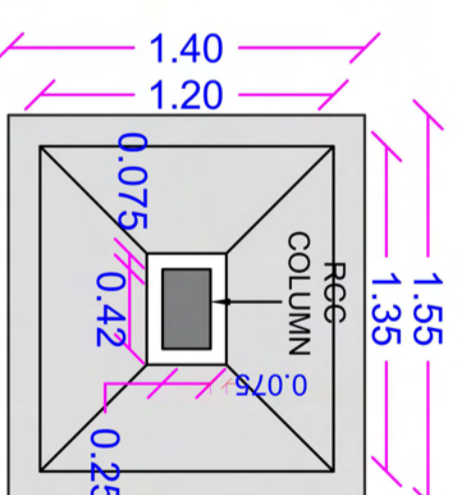

PLAN

DETAILS OF FOOTING

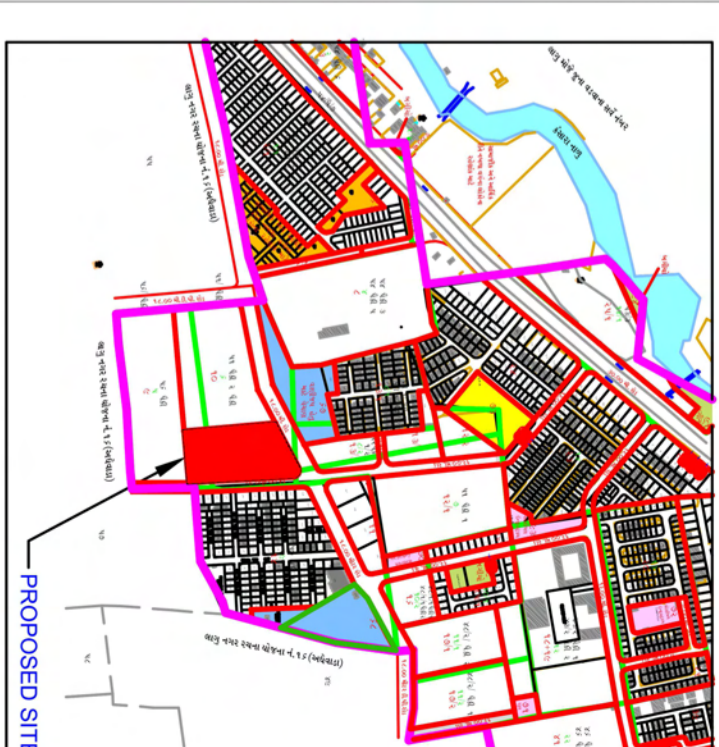

KEY PLAN

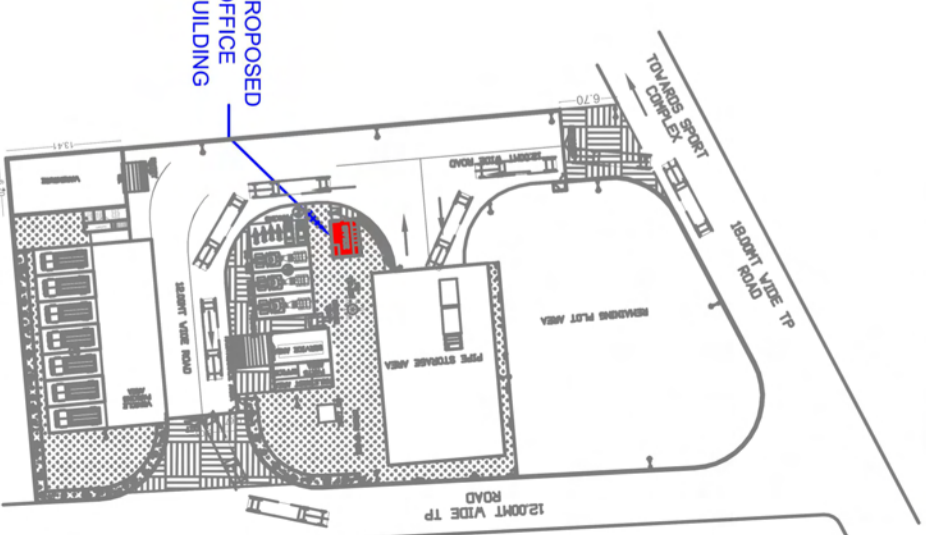

LAYOUT PLAN

## SCHEDULE OF OPENINGS

MARK	SIZE	HIGHT OF SILL	NOS.
D	1000 x 2100		2
W	1200 x 1500	900	4

## TENDER DRAWING

NO	DATE	DESCRIPTION	SIGNATURE
		PROJECT:- CONSULTANCY SERVICE FOR PREPARATION OF DPR, DTP AND PMC SERVICE OF SEWAGE PROJECT UNDER AMRUT 2.0 OF BHAVNAGAR CITY.	
		CLIENT:- THE EXECUTIVE ENGINEER, DRAINAGE DEPARTMENT, MUNICIPAL CORPORATION, CENTRAL OFFICE BUILDING, SIR MANGAL SIMHJI ROAD, BHAVNAGAR-384001	

CONSULTANT:- FACILE MAVEN PRIVATE LIMITED  
 1701, 2 & 3, Rio Empire, Ph: +91 -261 - 6575998  
 Opp. Pal RTO, Pal, Surat - Fax: +91 -261 - 2733584  
 395009 Email: info@facilemaven.com

TITLE:- FURNITURE LAYOUT PLAN OF OFFICE BUILDING

DRAWN BY :-	AKSHAY	DESIGNED BY :-	PURVA
CHECKED BY :-	A.K. GARG	PROJ. NO. :-	-
SCALE :-	N.T.S	DRG. NO. :-	BMC/DSA07
DATE :-	18/11/2024	REVISION :-	R0



# DETAILS OF WAREHOUSE

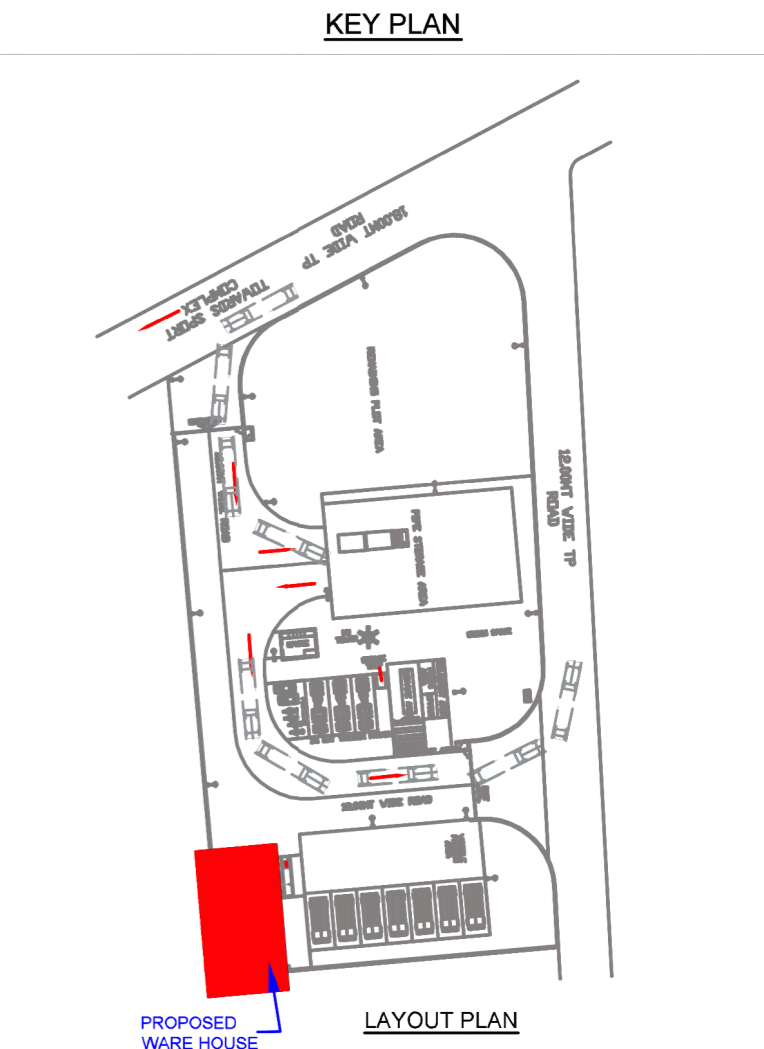
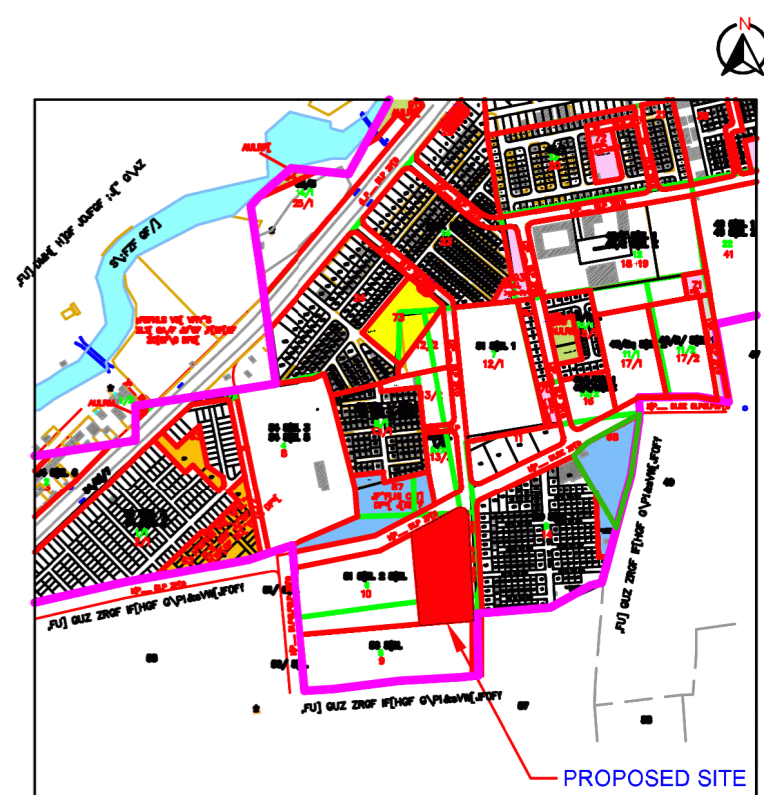
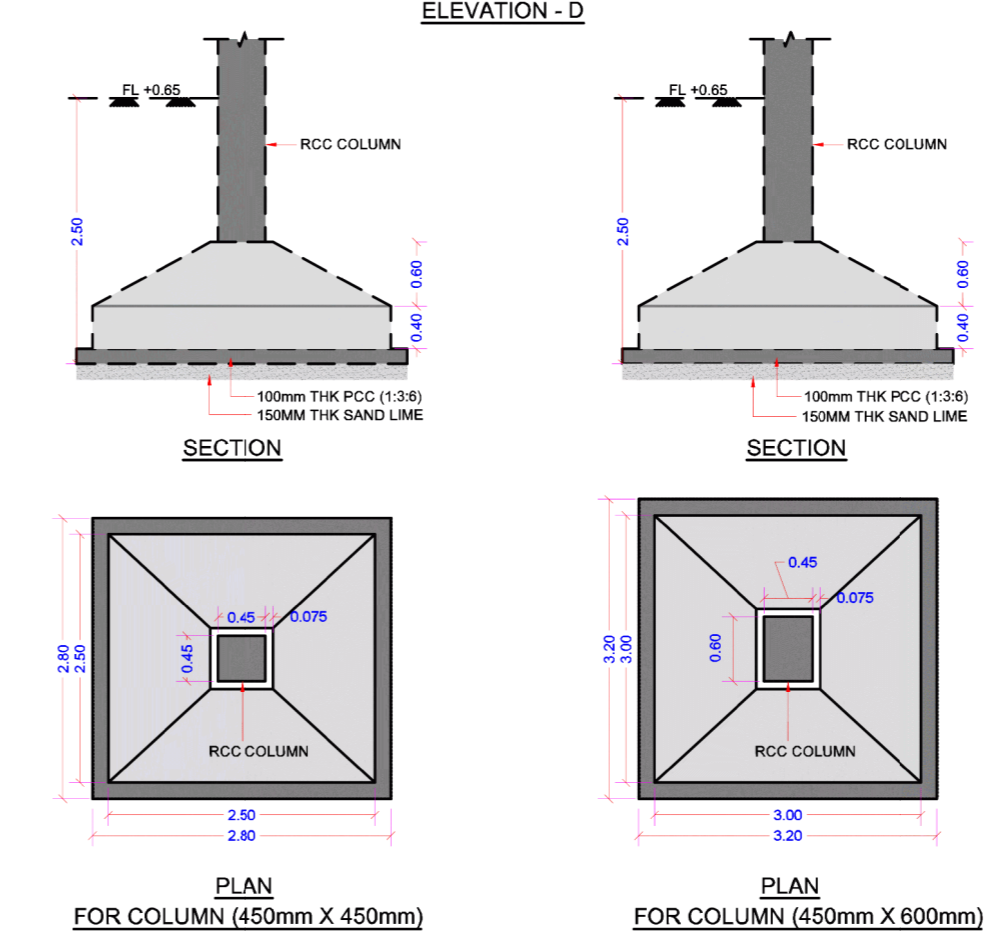
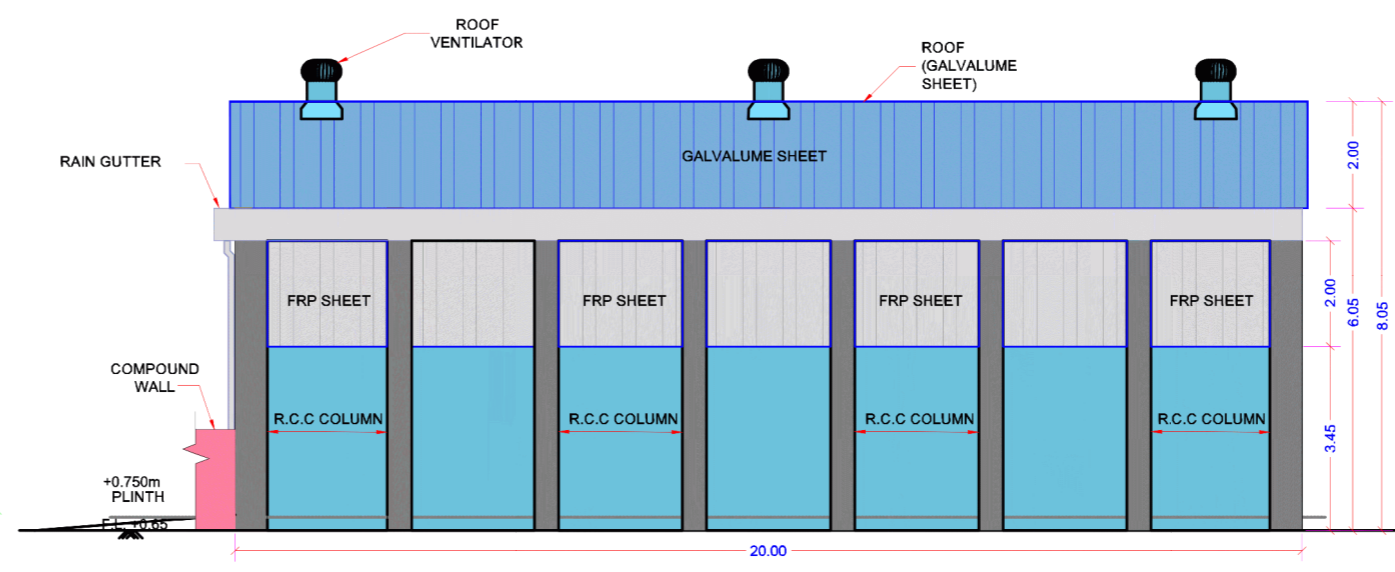
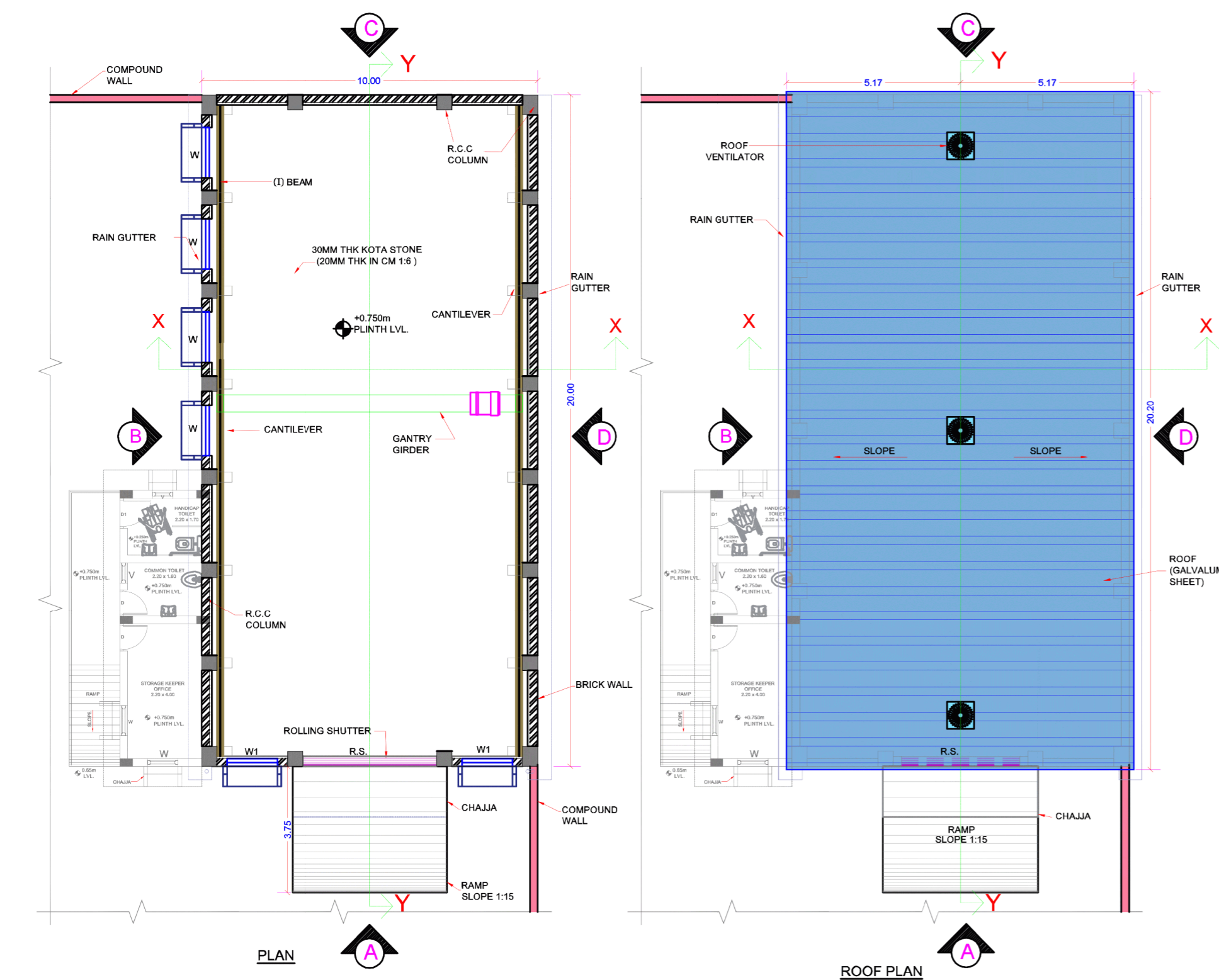
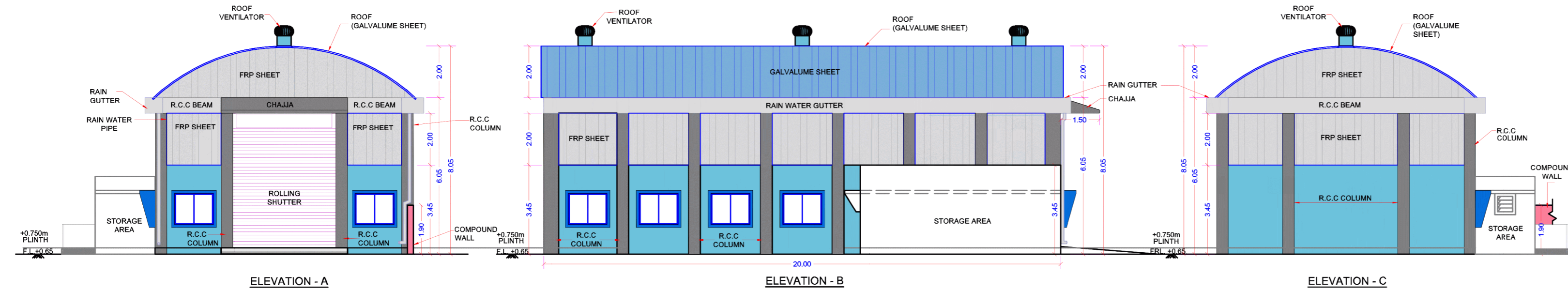
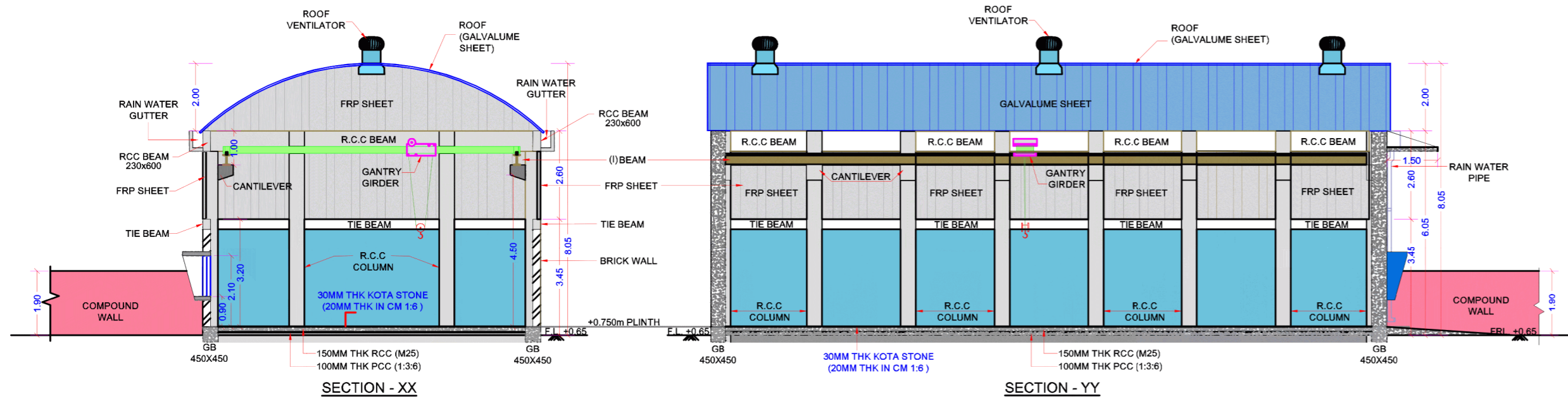

## SCHEDULE OF OPENINGS

MARK	SIZE	HEIGHT OF SILL LVL.	NOS.
W	1800 x 1200	600	3
W1	1500 x 1200	600	2
R.S.	4000 x 4700		1

## TENDER DRAWING

NO	DATE	DESCRIPTION	SIGNATURE
PROJECT:- CONSULTANCY SERVICE FOR PREPARATION OF DPR, DTP AND PMC SERVICE OF SEWAGE PROJECT UNDER AMRUT 2.0 OF BHAVNAGAR CITY.			
CLIENT:- THE EXECUTIVE ENGINEER, DRAINAGE DEPARTMENT, MUNICIPAL CORPORATION, CENTRAL OFFICE BUILDING, SIR MANGALSINHJI ROAD, BHAVNAGAR-364001			
CONSULTANT:- FACILE MAVEN PRIVATE LIMITED			
1701, 2 & 3, Rio Empire, Ph: + 91 - 261 - 6575998 Opp. Pal RT0, Pal, Surat - Fax: + 91 - 261 - 2733584 395009 Email: infra@facilemaven.com			
TITLE:- GENERAL ARRANGEMENT AND DETAILS OF WAREHOUSE			
DRAWN BY :-	AKSHAY	DESIGNED BY :-	PURVA
CHECKED BY :-	A.K. GARG	PROJ. NO. :-	-
SCALE :-	N.T.S	DRG. NO. :-	BMC/DSA/08
DATE :-	18/11/2024	REVISION :-	R0



# DETAILS OF STORE KEEPER AREA, COMMON TOILET, HANDICAP TOILET AND RAMP

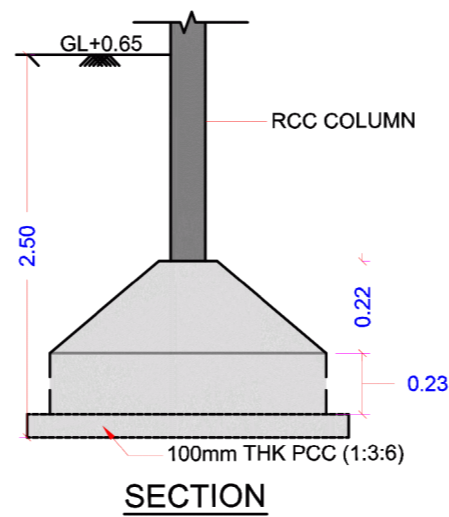
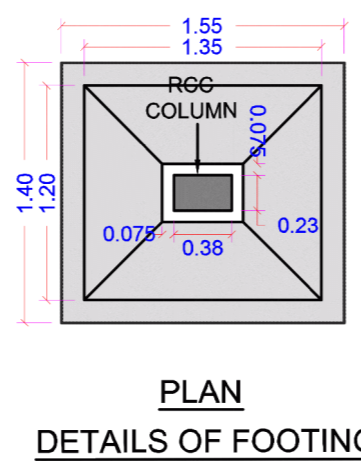
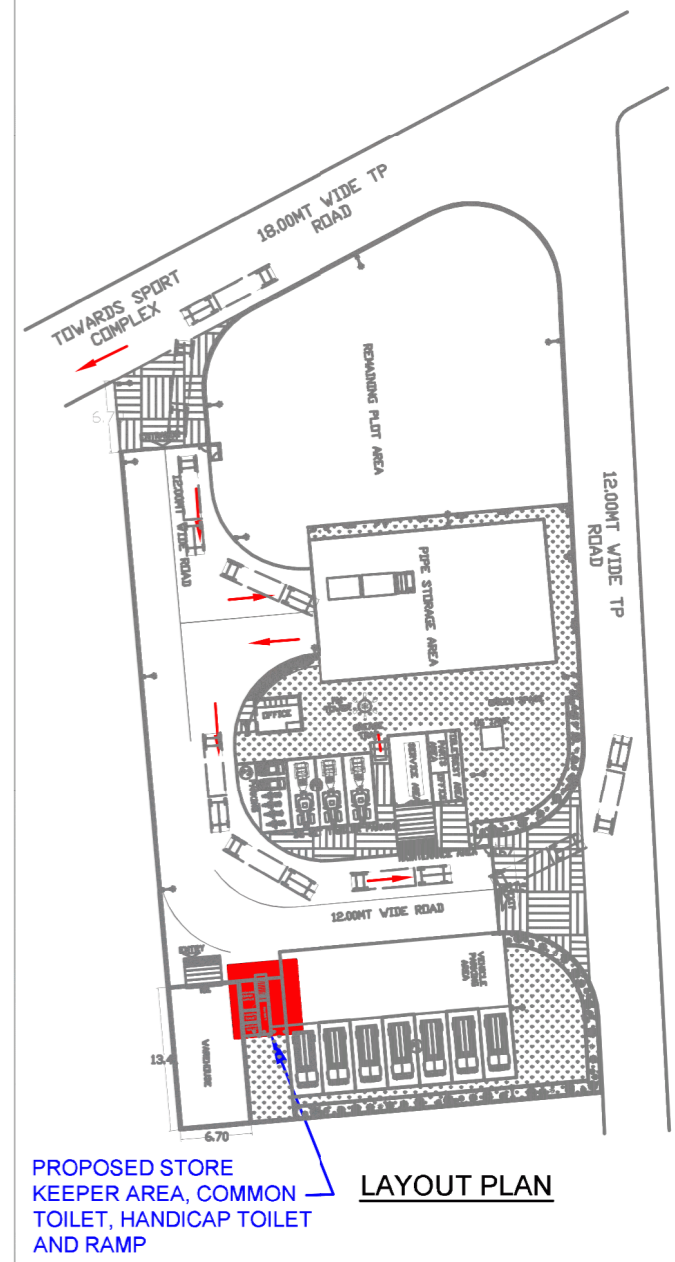
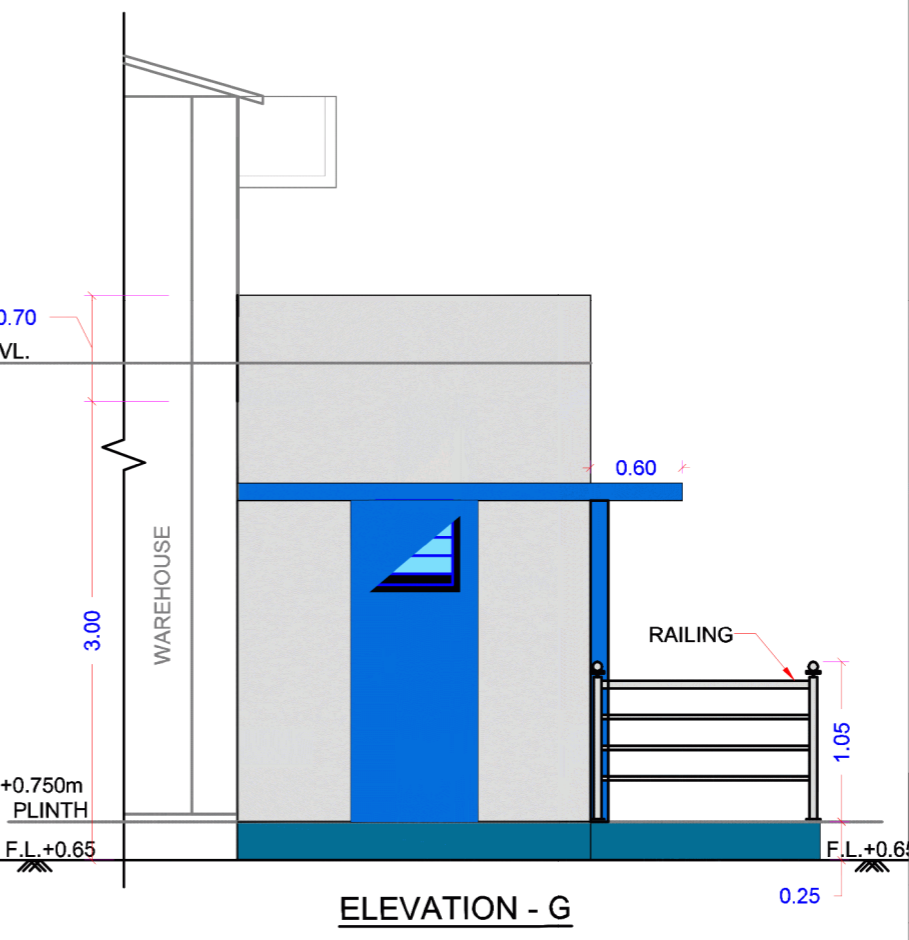
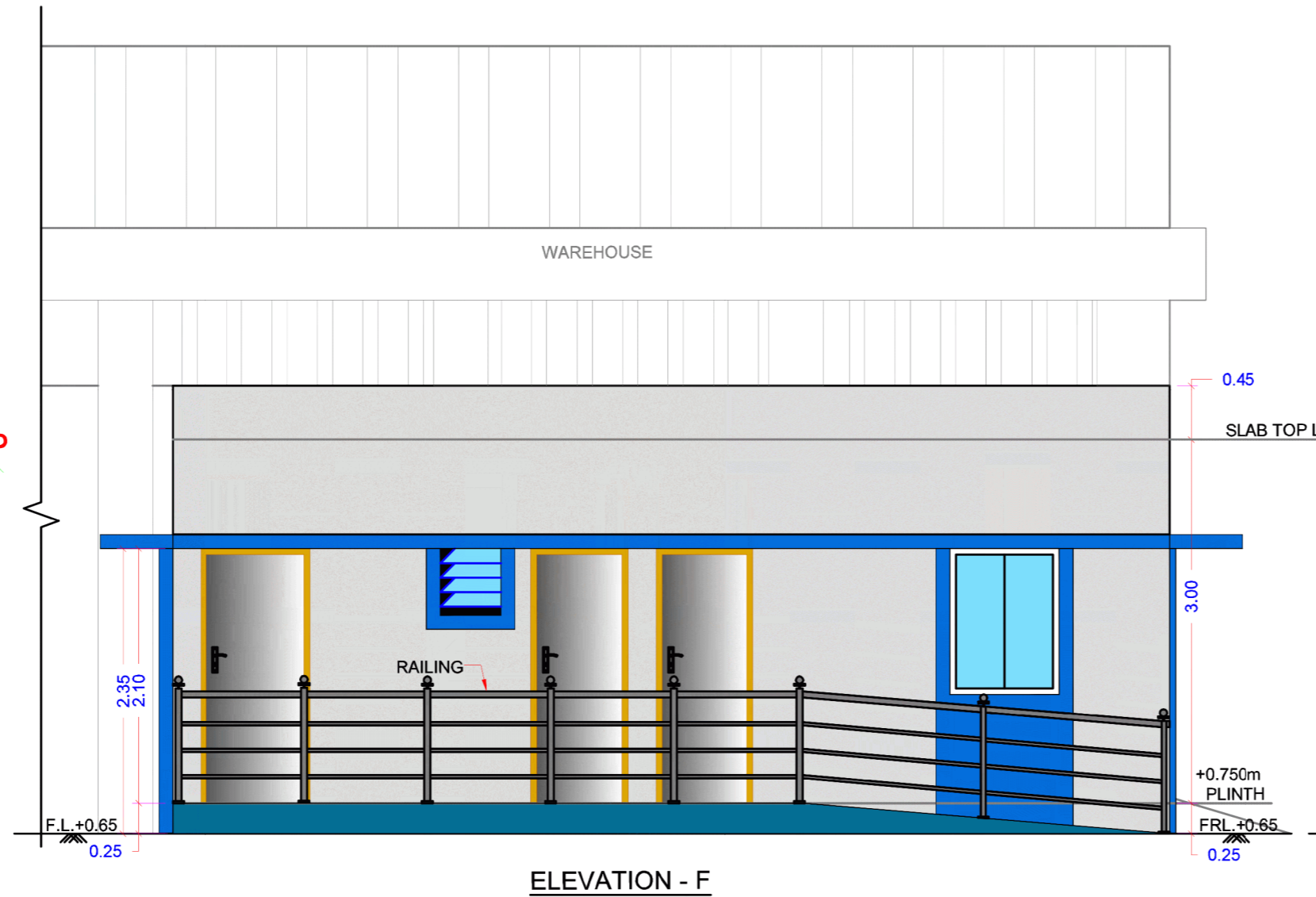
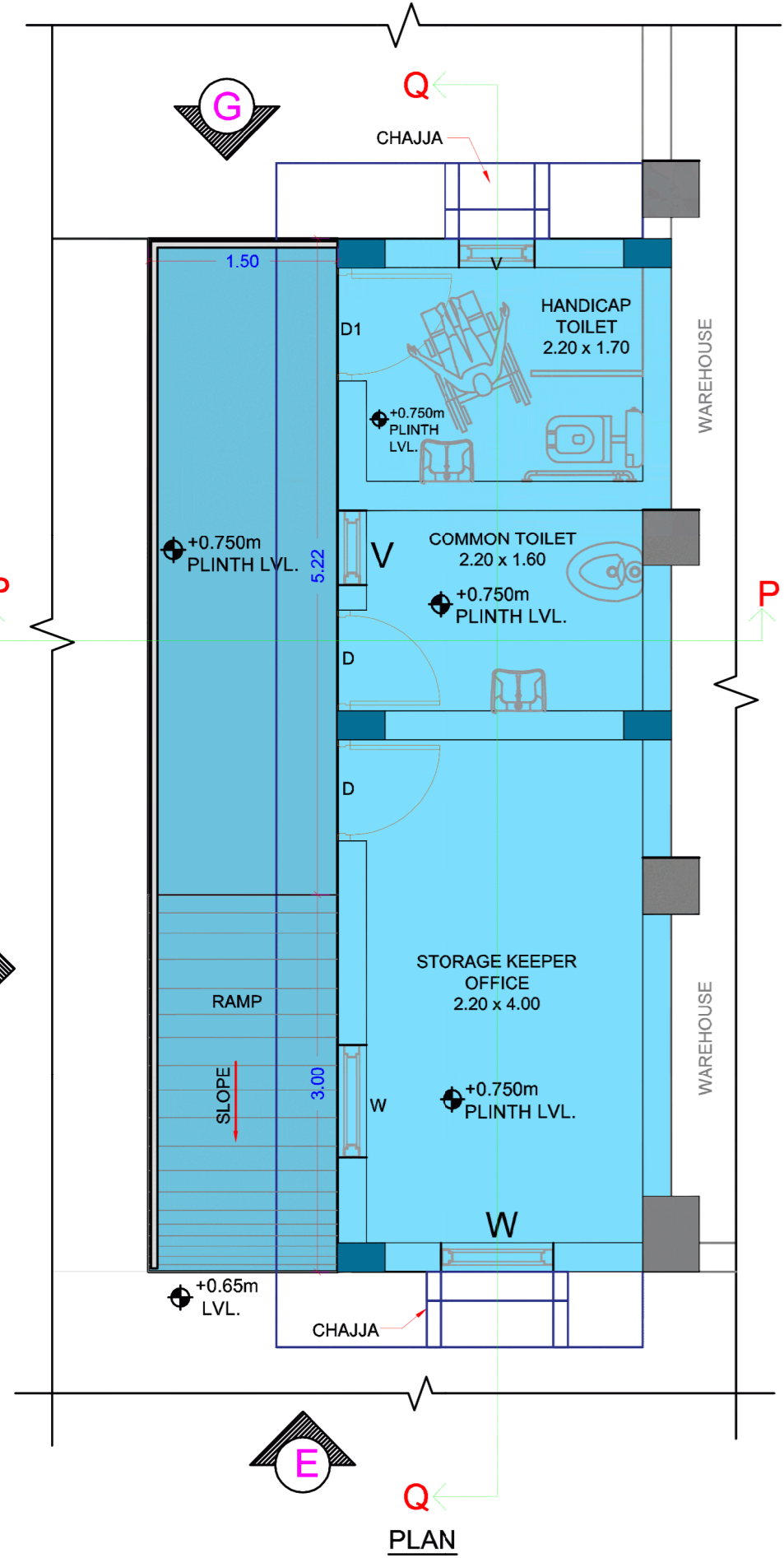
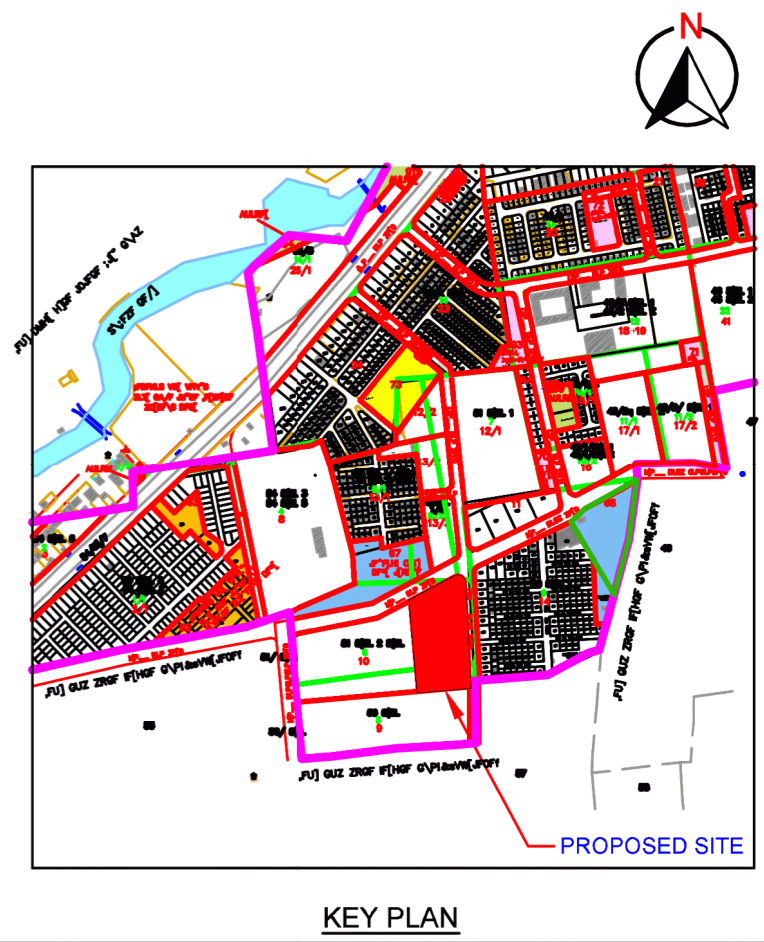
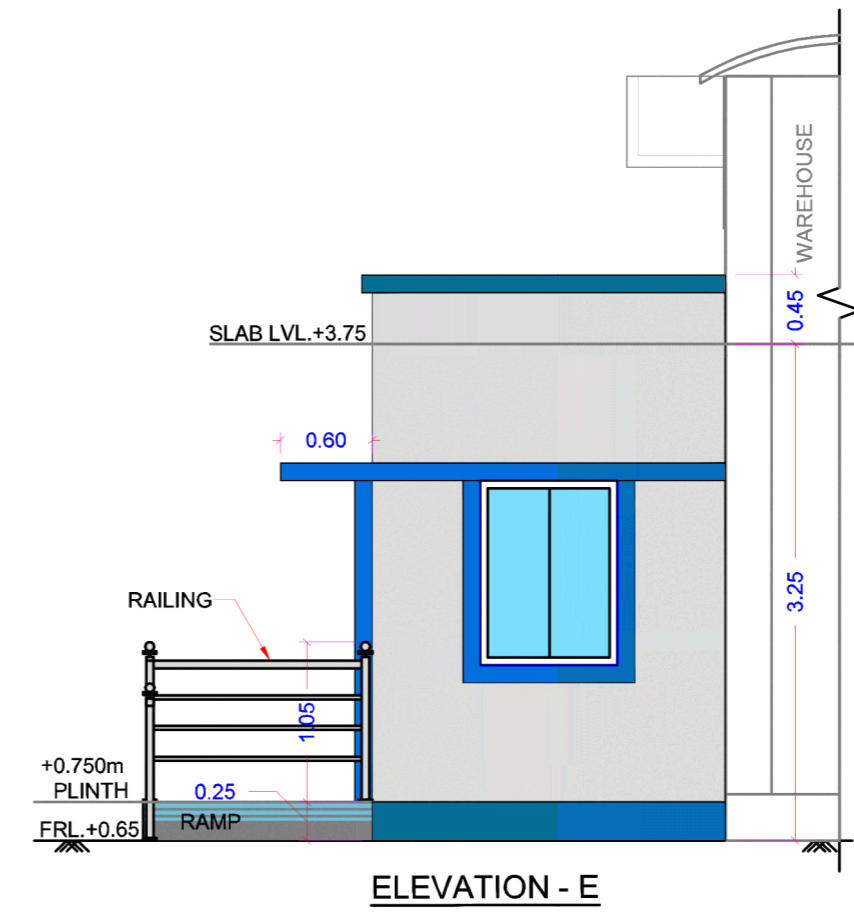
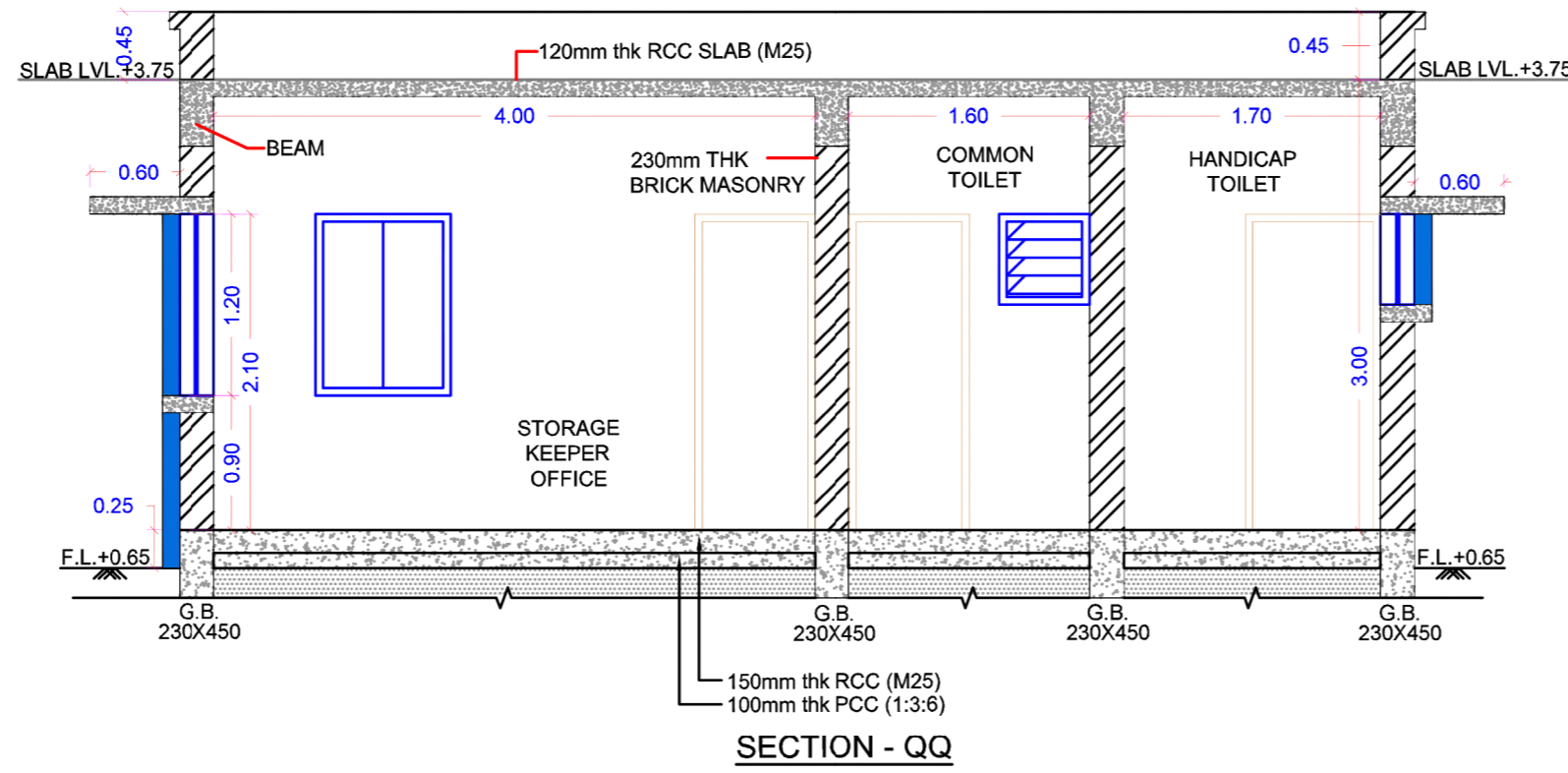
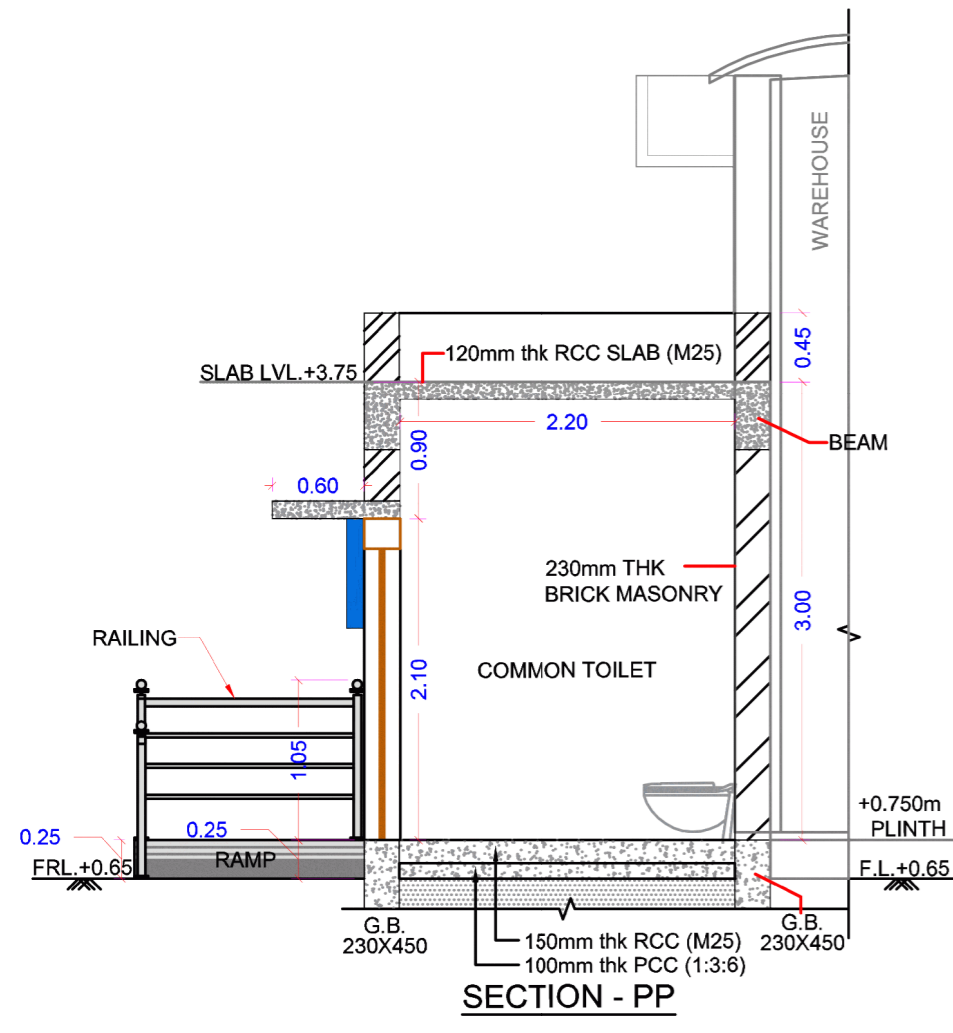

## SCHEDULE OF OPENINGS

WAREHOUSE			
MARK	SIZE	HEIGHT OF SILL LVL.	NOS.
W	900 x 1000	1010	1
V	600 x 600	1500	2
D	800 x 2100	_____	2
D1	900 x 2100	_____	1

**TENDER DRAWING**

NO	DATE	DESCRIPTION	SIGNATURE
PROJECT:- CONSULTANCY SERVICE FOR PREPARATION OF DPR, DTP AND PMC SERVICE OF SEWAGE PROJECT UNDER AMRUT 2.0 OF BHAVNAGAR CITY.			
CLIENT:- THE EXECUTIVE ENGINEER, DRAINAGE DEPARTMENT, MUNICIPAL CORPORATION, CENTRAL OFFICE BUILDING, SIR MANGALSINHIJI ROAD, BHAVNAGAR-364001			
CONSULTANT:- FACILE MAVEN PRIVATE LIMITED			
1701, 2 & 3, Rio Empire, Ph: + 91 - 261 - 6575998		Opp. Pal RTO, Pal, Surat - Fax : + 91 - 261 - 2733584	
395009		Email : infra@facilemaven.com	
TITLE:- DETAILS OF STORE KEEPER AREA, COMMON TOILET, HANDICAP TOILET AND RAMP			
DRAWN BY :-	AKSHAY	DESIGNED BY :-	PURVA
CHECKED BY :-	A.K. GARG	PROJ. NO. :-	-
SCALE :-	N.T.S	DRG. NO. :-	BMC/DSA/09
DATE :-	18/11/2024	REVISION :-	R0



# DETAILS OF STORE KEEPER AREA, COMMON TOILET, HANDICAP TOILET AND RAMP

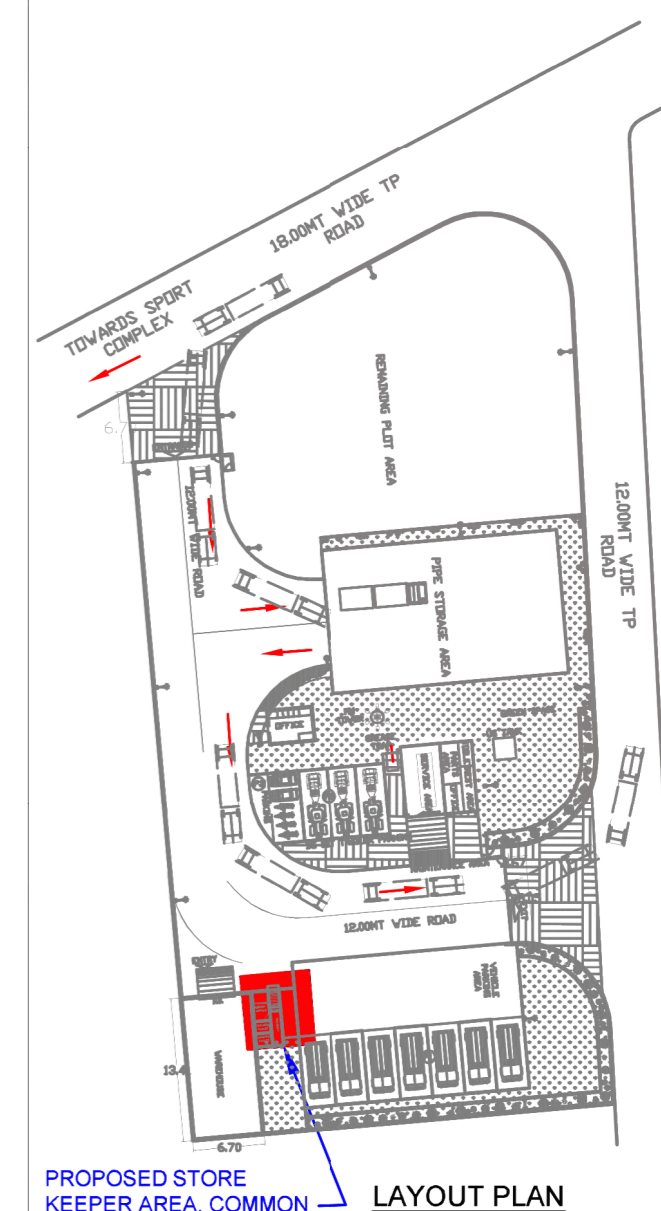
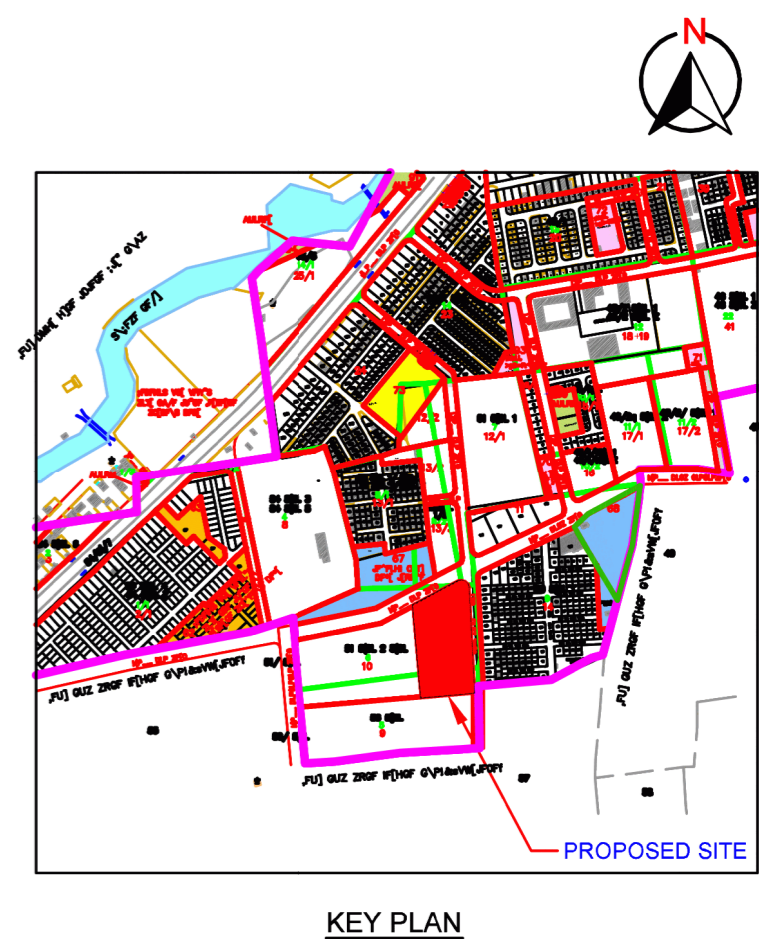
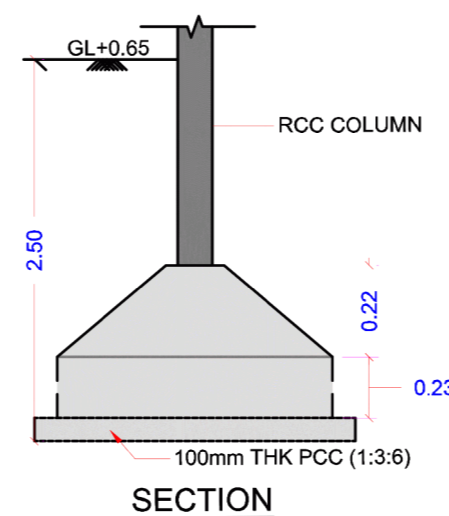
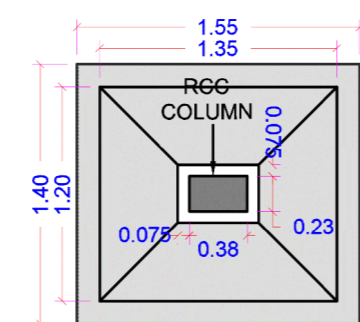
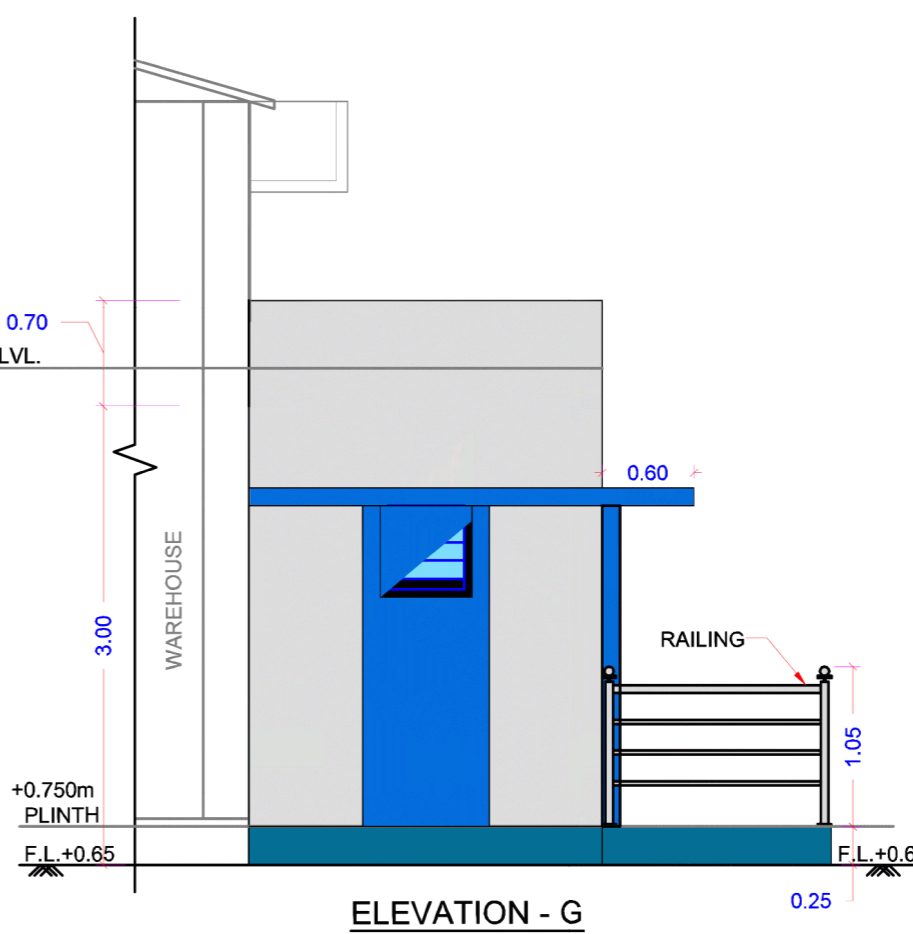
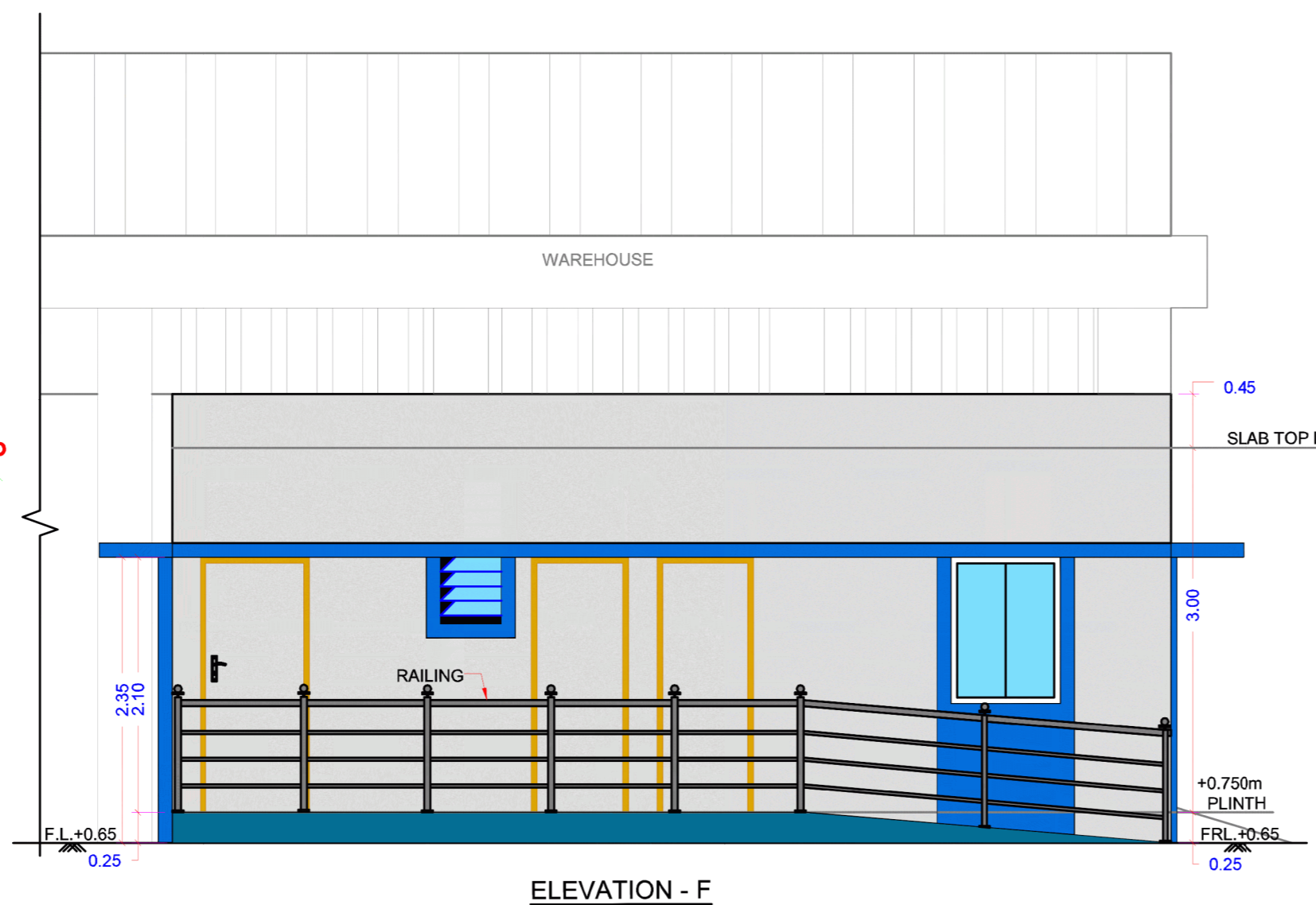
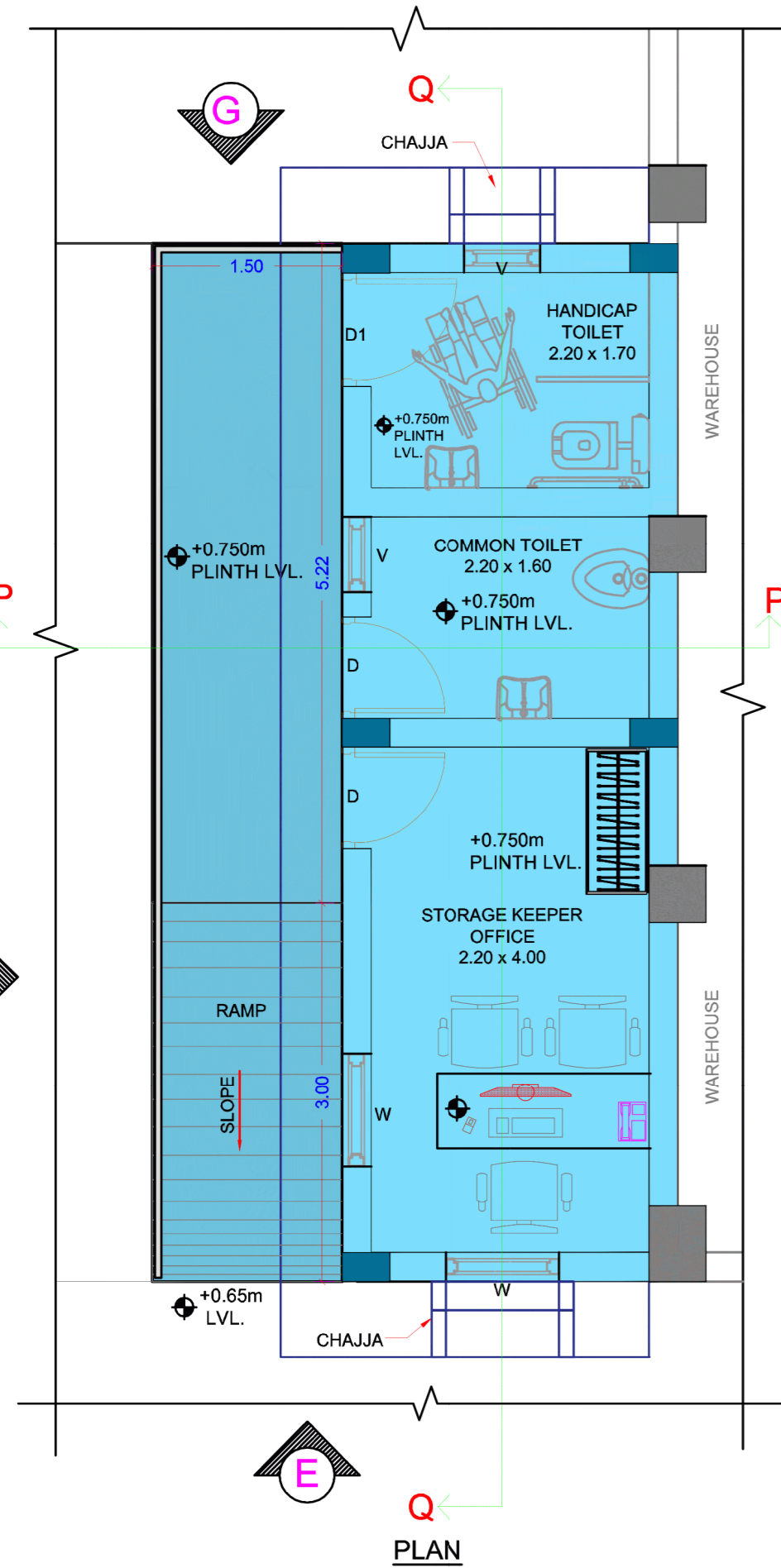
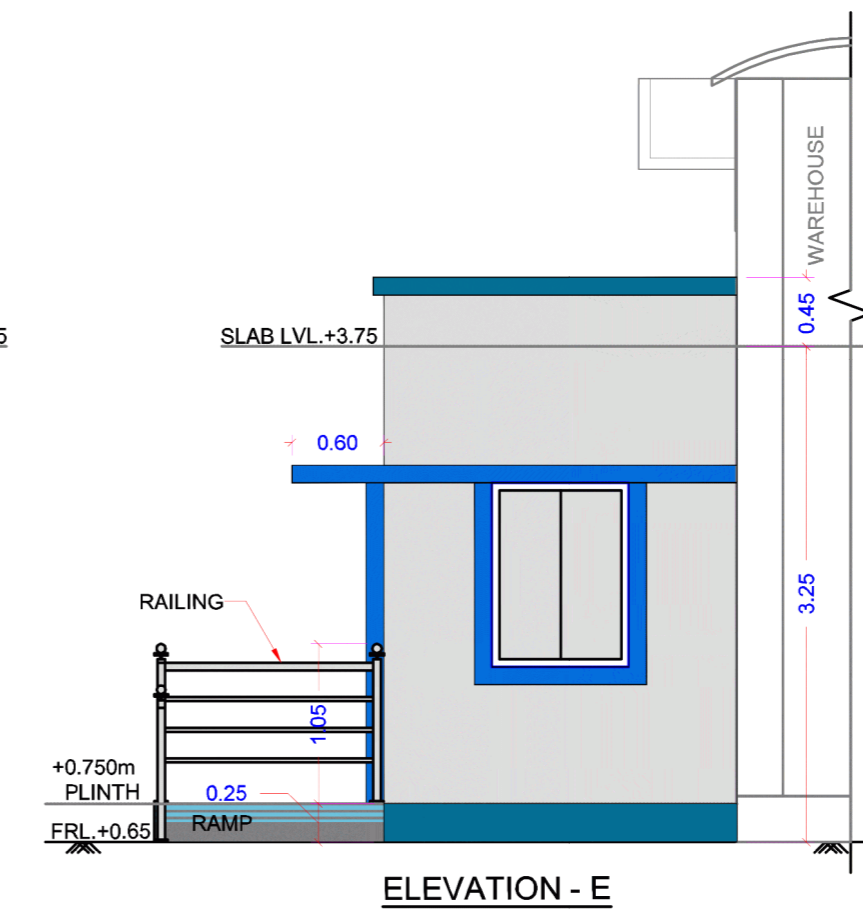
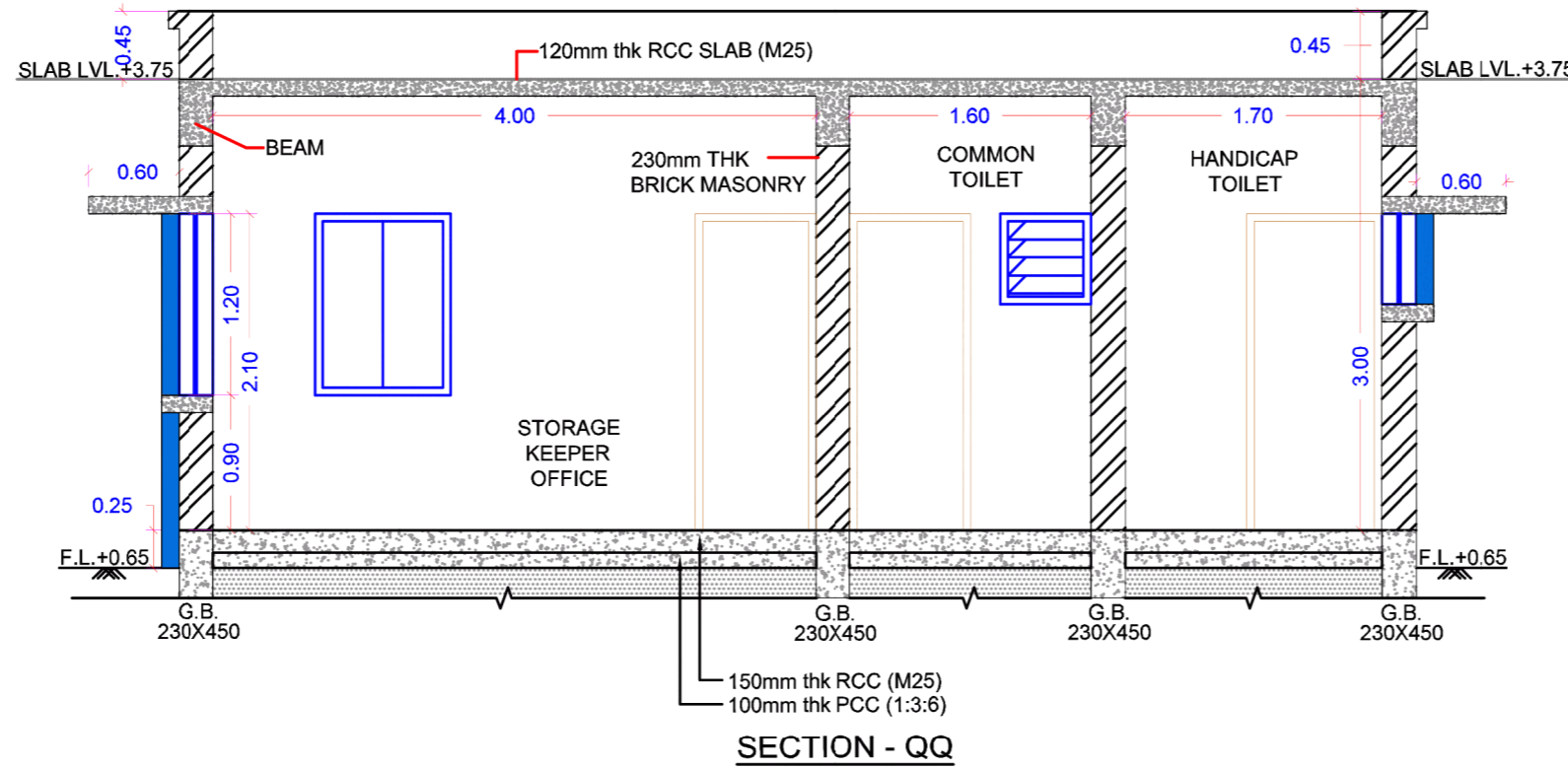
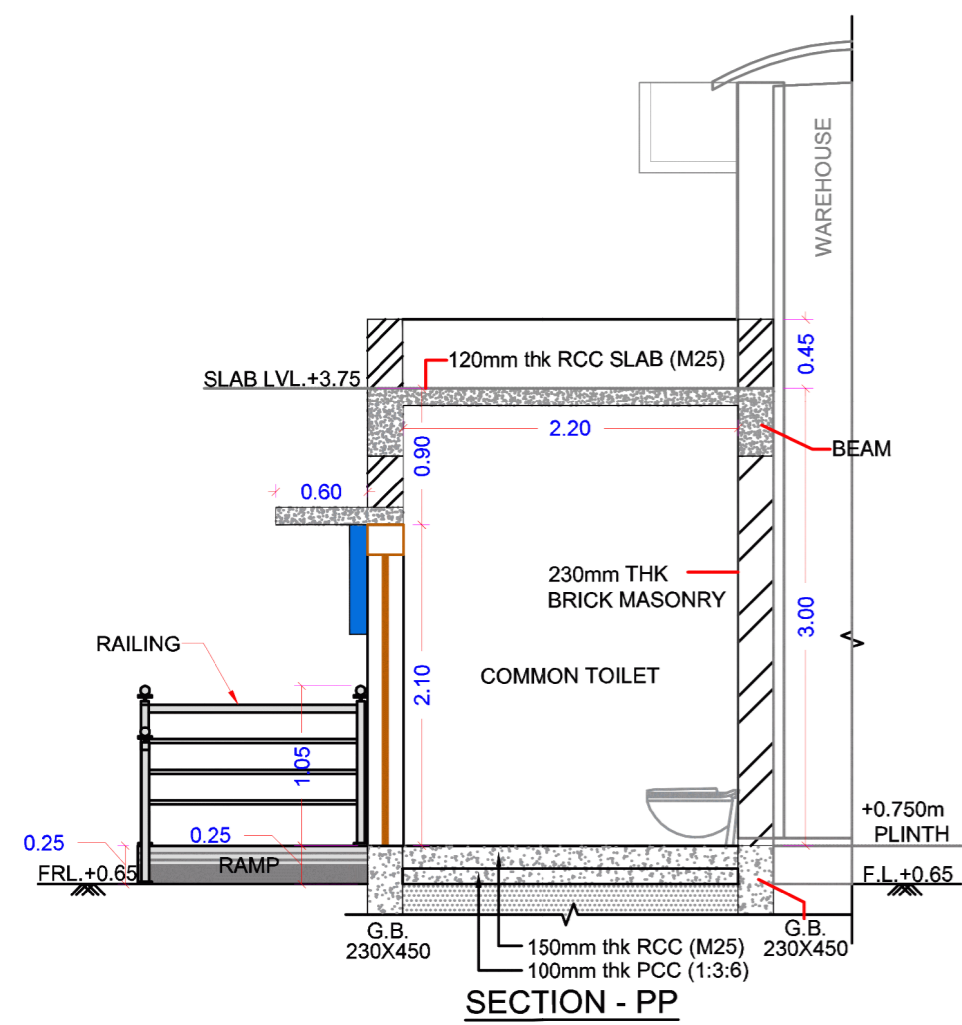

## TENDER DRAWING

NO	DATE	DESCRIPTION	SIGNATURE
PROJECT:- CONSULTANCY SERVICE FOR PREPARATION OF DPR, DTP AND PMC SERVICE OF SEWAGE PROJECT UNDER AMRUT 2.0 OF BHAVNAGAR CITY.			
CLIENT:- THE EXECUTIVE ENGINEER, DRAINAGE DEPARTMENT, MUNICIPAL CORPORATION, CENTRAL OFFICE BUILDING, SIR MANGALSINHJI ROAD, BHAVNAGAR-364001			
CONSULTANT:- FACILE MAVEN PRIVATE LIMITED			
 1701, 2 & 3, Rio Empire, Ph: + 91 - 261 - 6575998 Opp. Pal RT0, Pal, Surat - Fax: + 91 - 261 - 2733584 395009 Email: infra@facilemaven.com			
TITLE:- FURNITURE LAYOUT PLAN OF STORE KEEPER AREA, COMMON TOILET, HANDICAP TOILET AND RAMP			
DRAWN BY :- AKSHAY		DESIGNED BY :- PURVA	
CHECKED BY :- A.K. GARG		PROJ. NO. :-	
SCALE :- N.T.S		DRG. NO. :- BMC/DSA/10	
DATE :- 18/11/2024		REVISION :- R0	

## SCHEDULE OF OPENINGS

WAREHOUSE			
MARK	SIZE	HEIGHT OF SILL LVL.	NOS.
W	900 x 1000	1010	1
V	600 x 600	1500	2
D	800 x 2100	—	2
D1	900 x 2100	—	1







DETAILS OF PARKING SHED AREA FOR CAR & VEHICLES

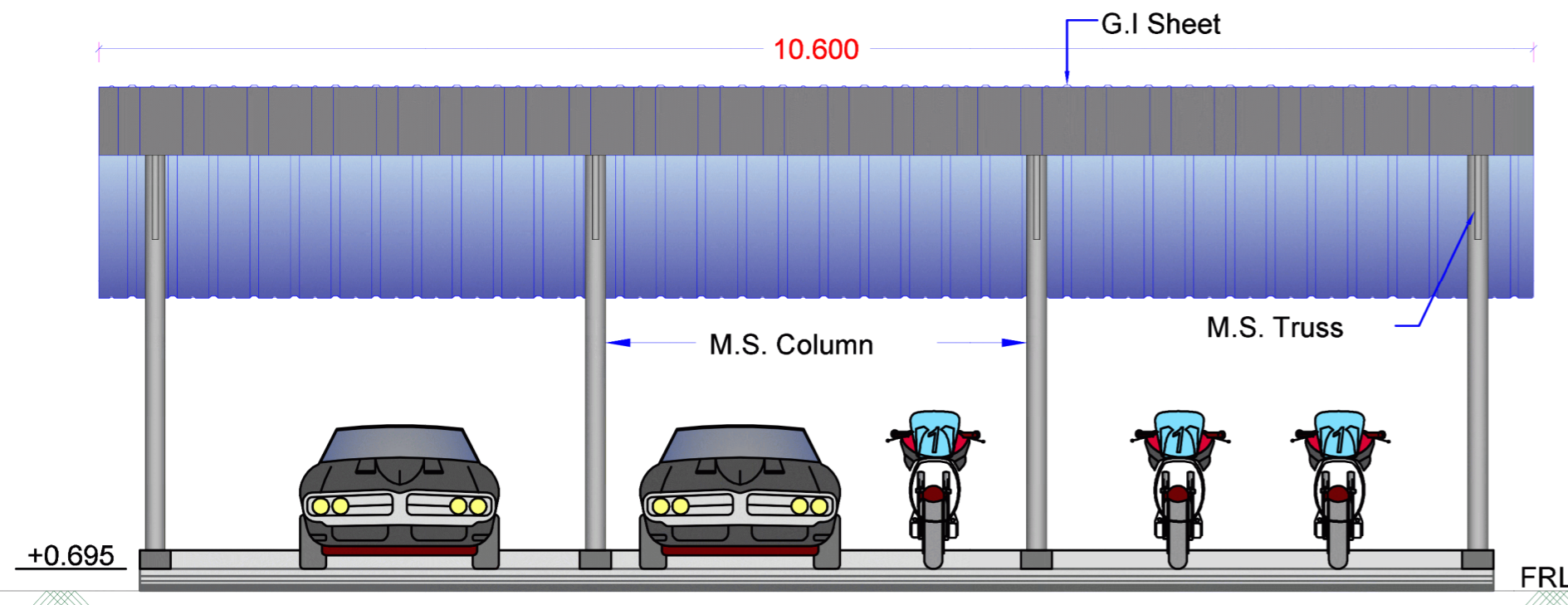

Front Elevation

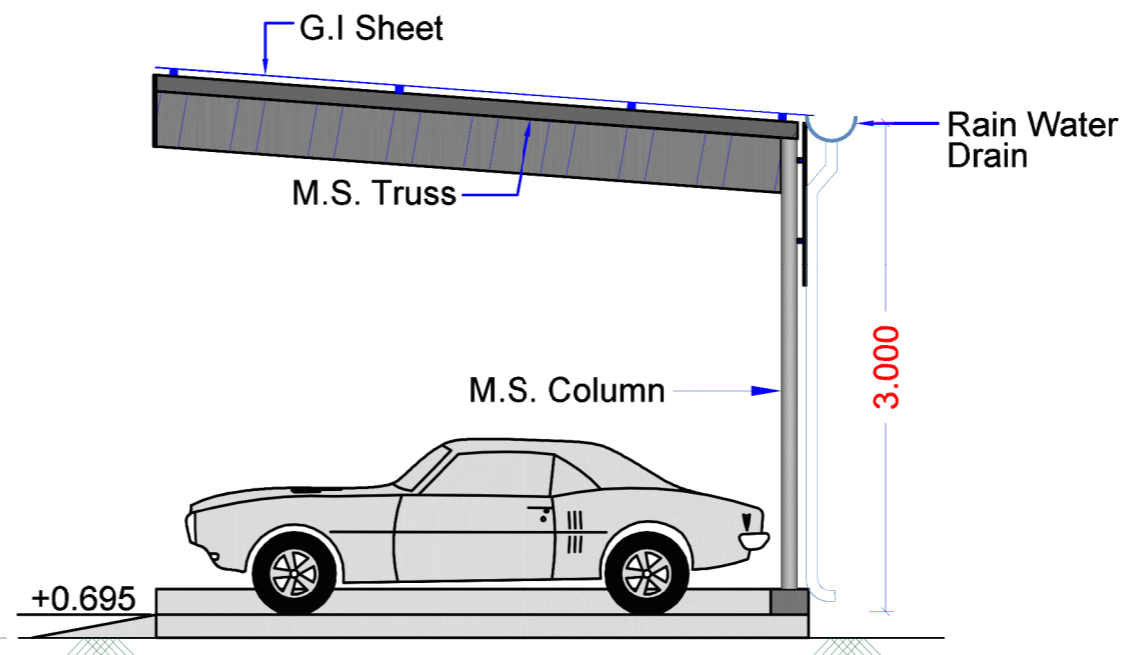

Side Elevation

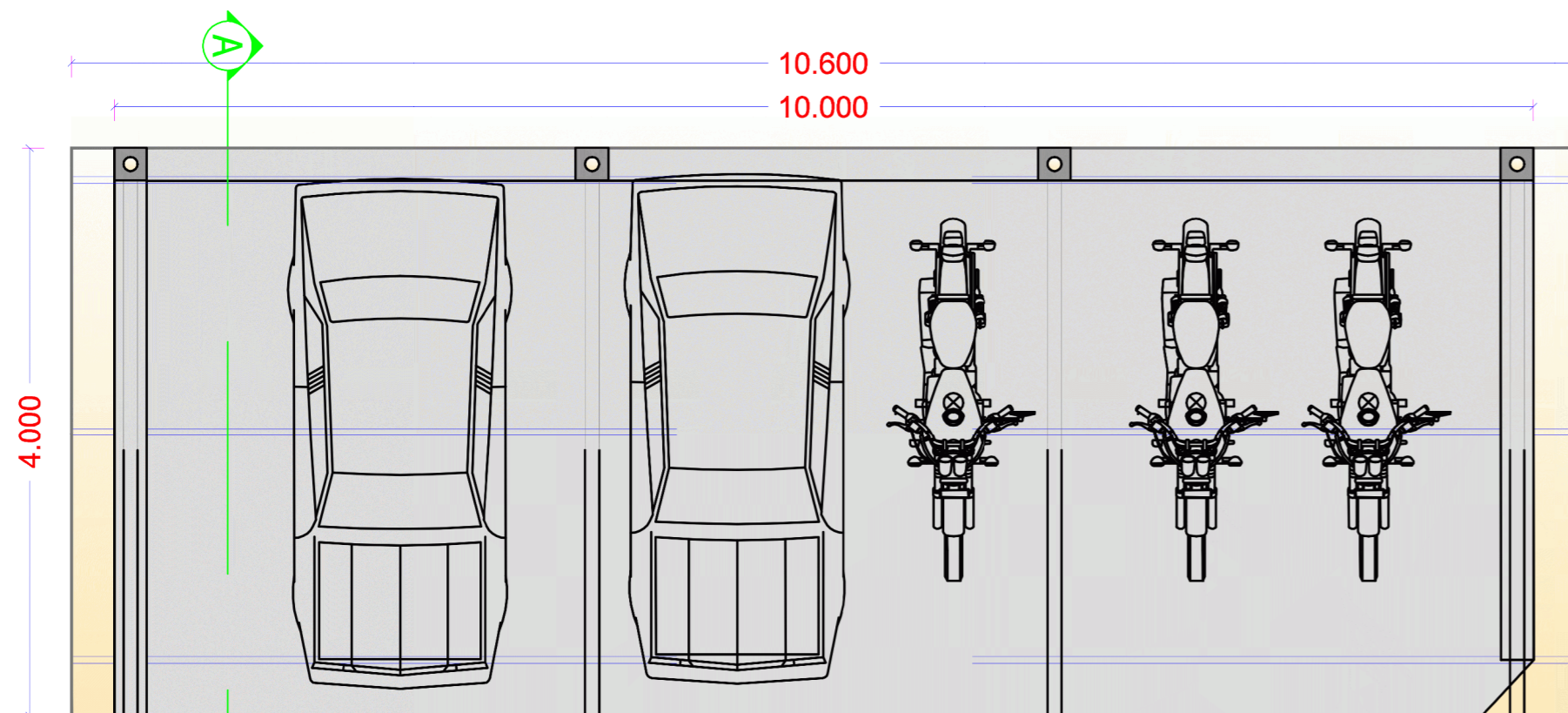

Plan  
Parking shed for car and vehicles

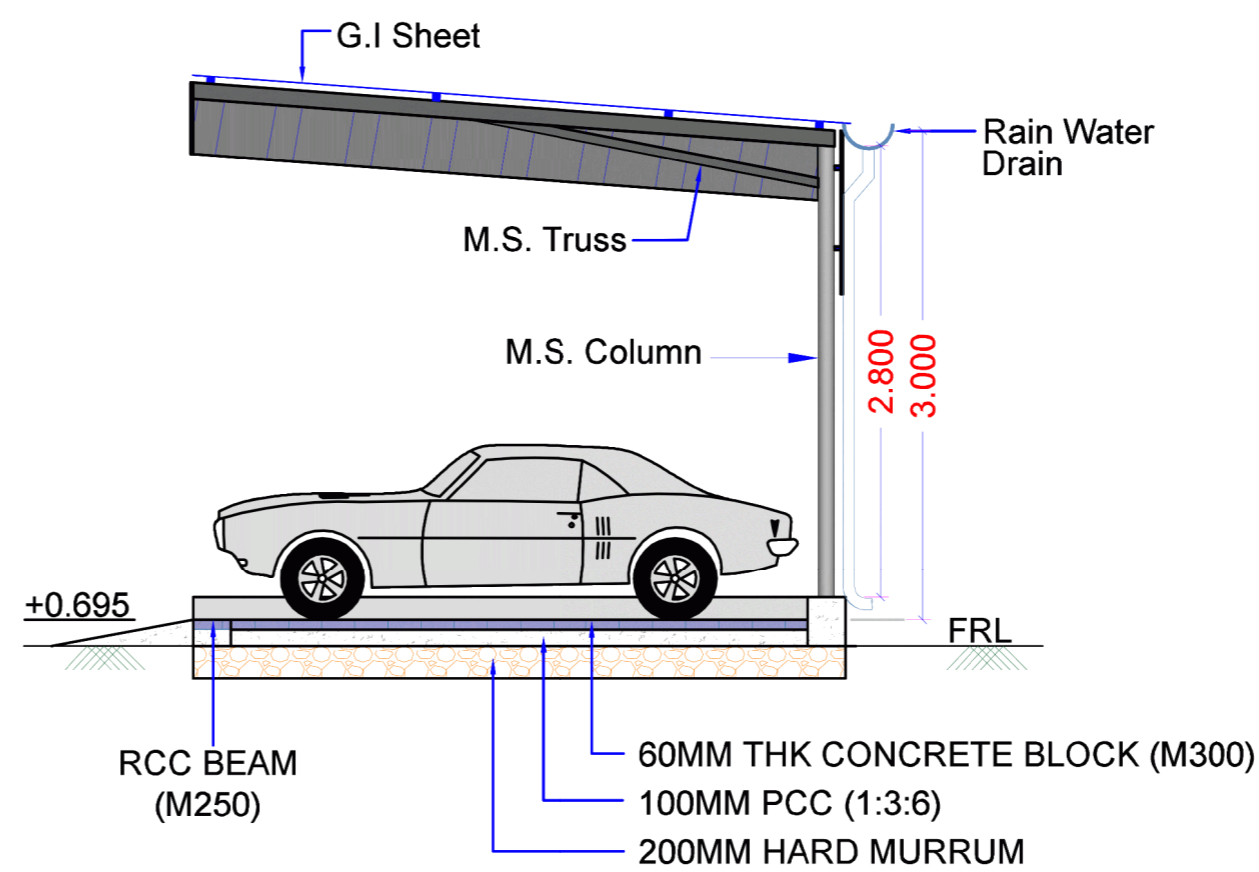

Section A-A

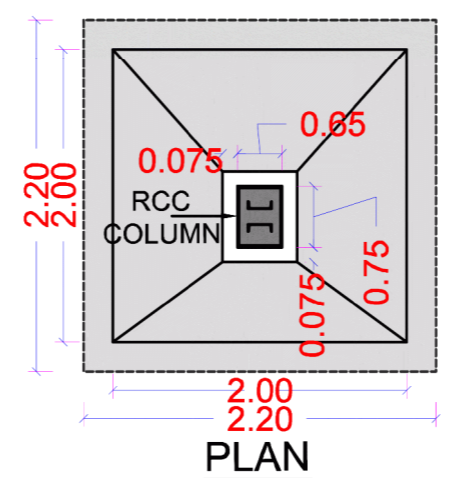

DETAILS OF FOOTING

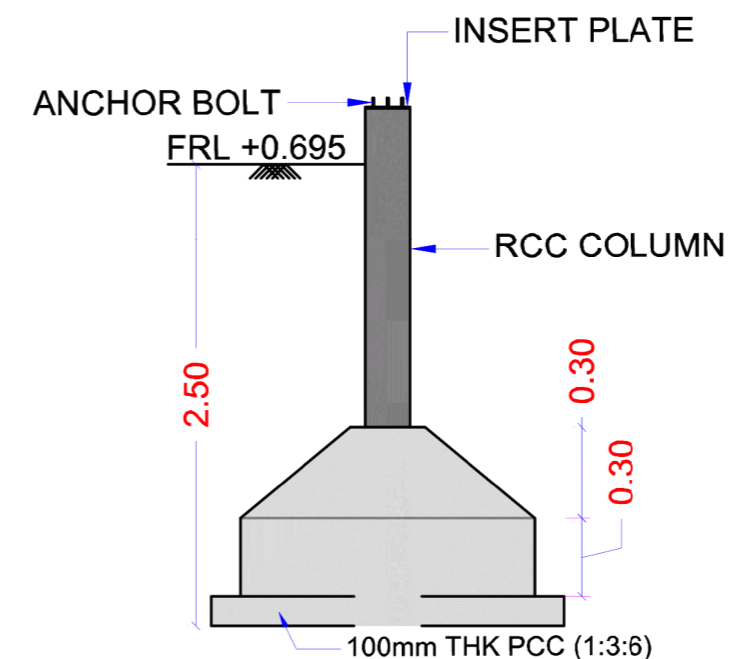

SECTION

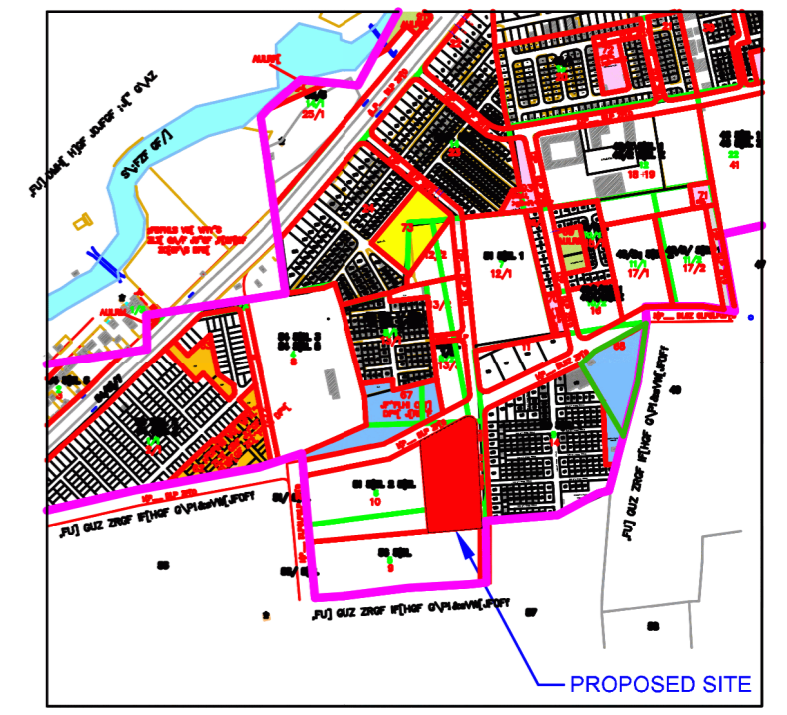

KEY PLAN

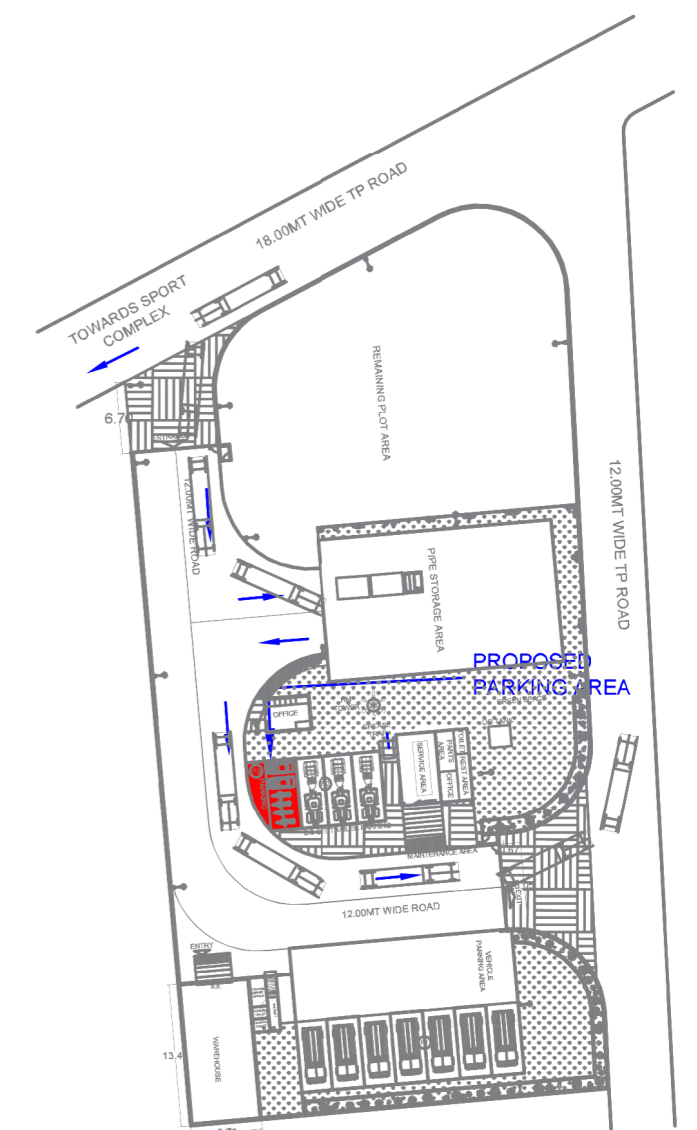

LAYOUT PLAN

TENDER DRAWING

NO	DATE	DESCRIPTION	SIGNATURE
PROJECT:- CONSULTANCY SERVICE FOR PREPARATION OF DPR, DTP AND PMC SERVICE OF SEWRAJE PROJECT UNDER AMRUT 2.0 OF BHAVNAGAR CITY.			
CLIENT:- THE EXECUTIVE ENGINEER, DRAINAGE DEPARTMENT, MUNICIPAL CORPORATION, CENTRAL OFFICE BUILDING, SIR MANGALSINHJI ROAD, BHAVNAGAR- 364001			
CONSULTANT:- FACILE MAVEN PRIVATE LIMITED			
		1701, 2 & 3, Rio Empire, Ph: + 91 - 261 - 6575998 Opp. Pal RTTO, Pal, Surat - Fax: + 91 - 261 - 2733584 395009 Email: infra@facilemaven.com	
TITLE:- DETAILS OF PARKING SHED AREA FOR CAR & VEHICLES			

DRAWN BY :-	DHAIRYA	DESIGNED BY :-	PURVA
CHECKED BY :-	A.K. GARG	PROJ. NO. :-	-
SCALE :-	N.T.S	DRG. NO. :-	BMC/DSA/12
DATE :-	18/11/2024	REVISION :-	R0



# DETAILS OF TRUCK PARKING SHED

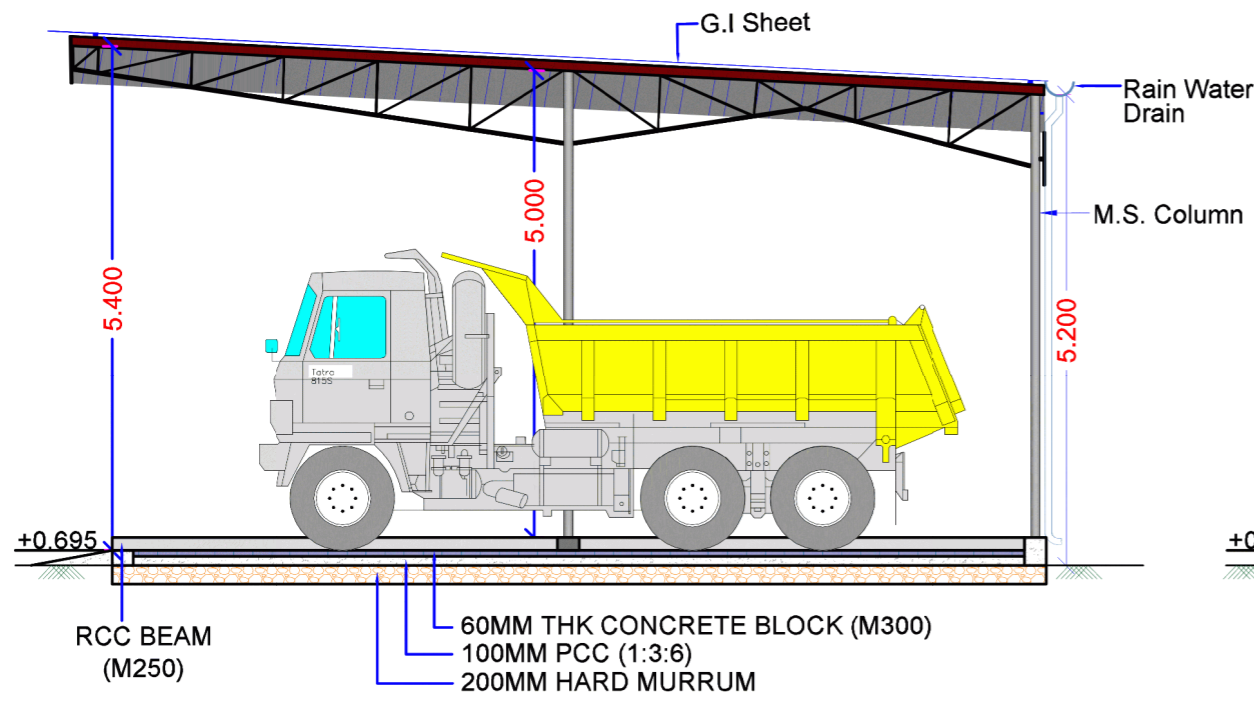

Section A-A

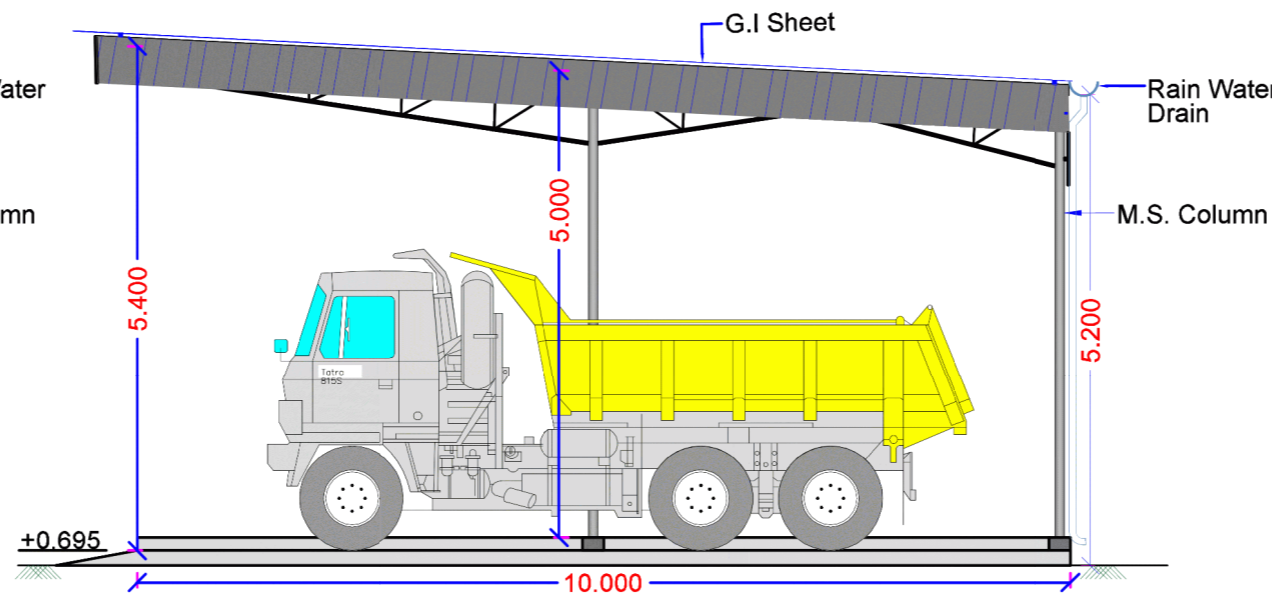

Side Elevation

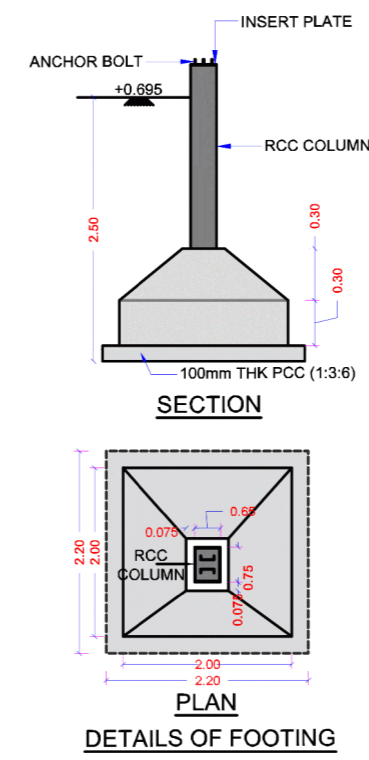

DETAILS OF FOOTING

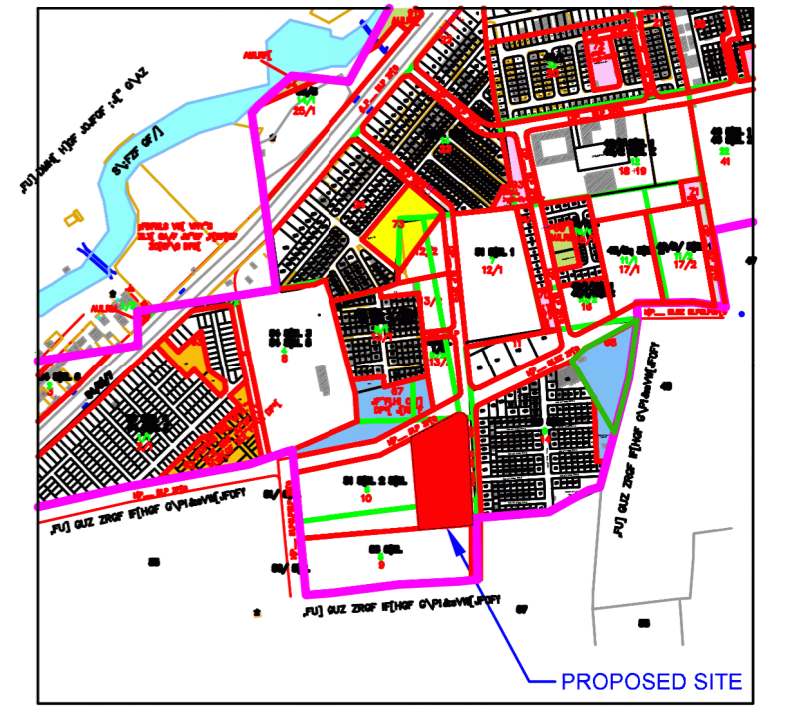

KEY PLAN

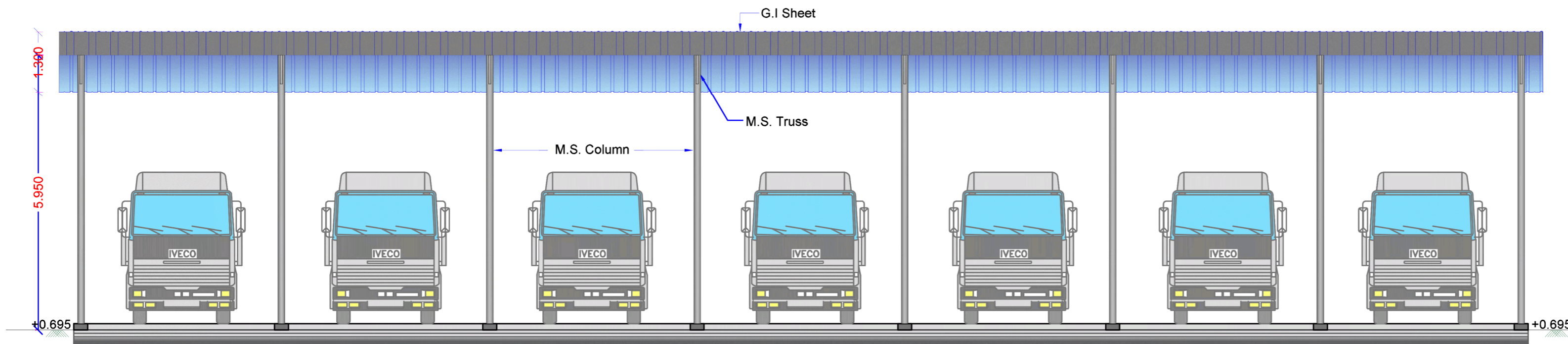

Front Elevation

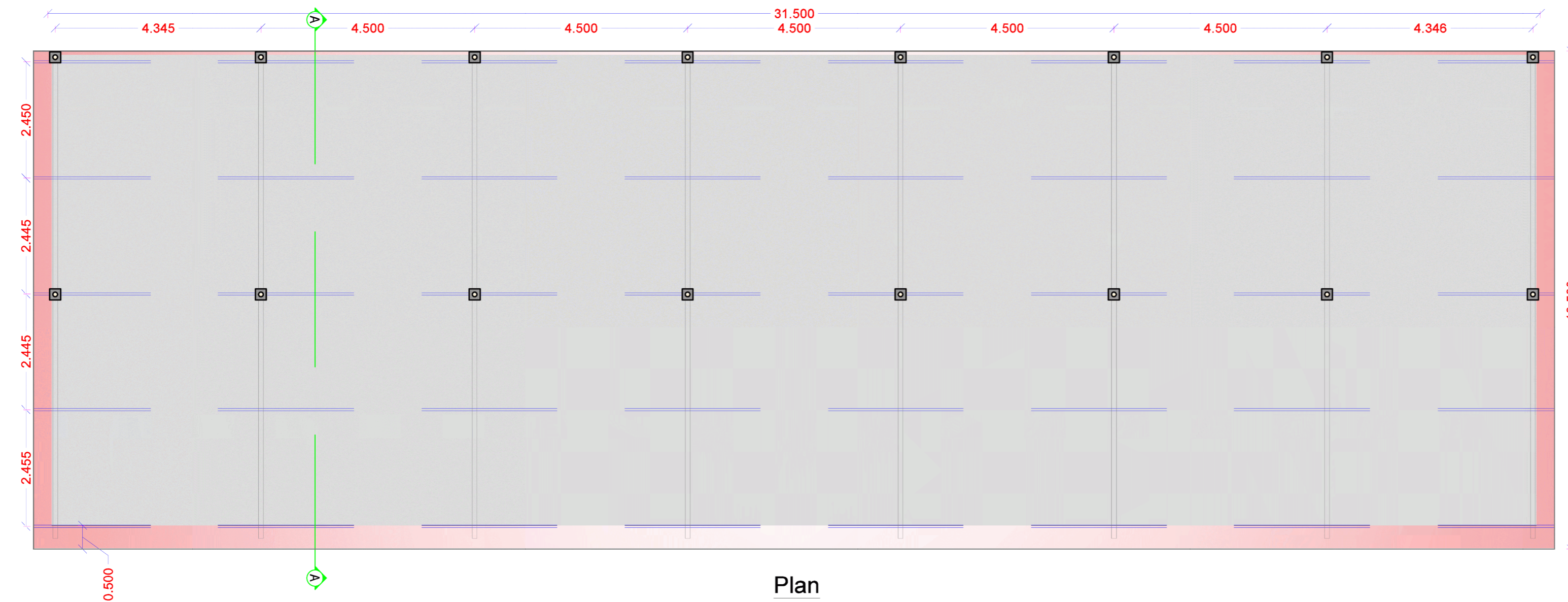

Plan  
Parking shed for truck

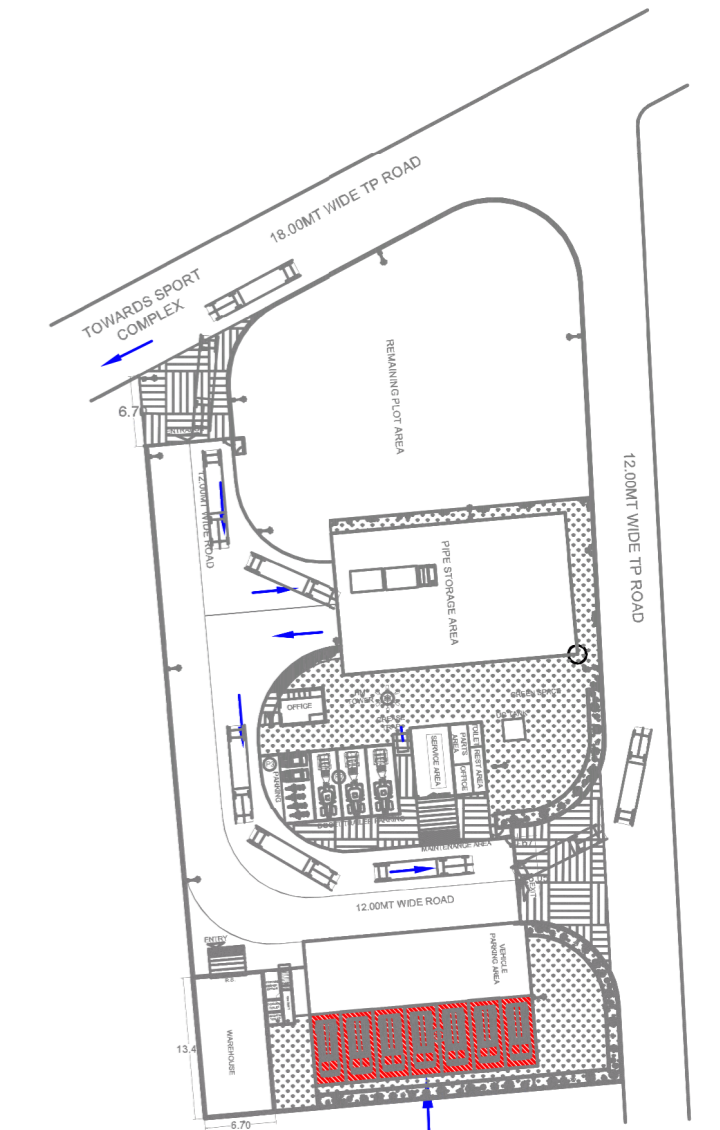

PROPOSED PRKING AREA  
LAYOUT PLAN

## TENDER DRAWING

NO	DATE	DESCRIPTION	SIGNATURE
PROJECT:- CONSULTANCY SERVICE FOR PREPARATION OF DPR, DTP AND PMC SERVICE OF SEWRAGE PROJECT UNDER AMRUT 2.0 OF BHAVNAGAR CITY.			
CLIENT:- THE EXECUTIVE ENGINEER, DRAINAGE DEPARTMENT, MUNICIPAL CORPORATION, CENTRAL OFFICE BUILDING, SIR MANGALSINHJI ROAD, BHAVNAGAR- 364001			
CONSULTANT:- FACILE MAVEN PRIVATE LIMITED  1701, 2 & 3, Rio Empire, Ph: + 91 - 261 - 6575998 Opp. Pal RTO, Pal, Surat - Fax : + 91 - 261 - 2733584 395009 Email : infra@facilemaven.com			
TITLE:- DETAILS OF TRUCK PARKING SHED			
DRAWN BY :-	DHAIRYA	DESIGNED BY :-	PURVA
CHECKED BY :-	A.K. GARG	PROJ. NO. :-	-
SCALE :-	N.T.S	DRG. NO. :-	BMC/DSA/13
DATE :-	18/11/2024	REVISION :-	RO



DETAILS OF PARKING SHED FOR TRACTOR GENERATOR

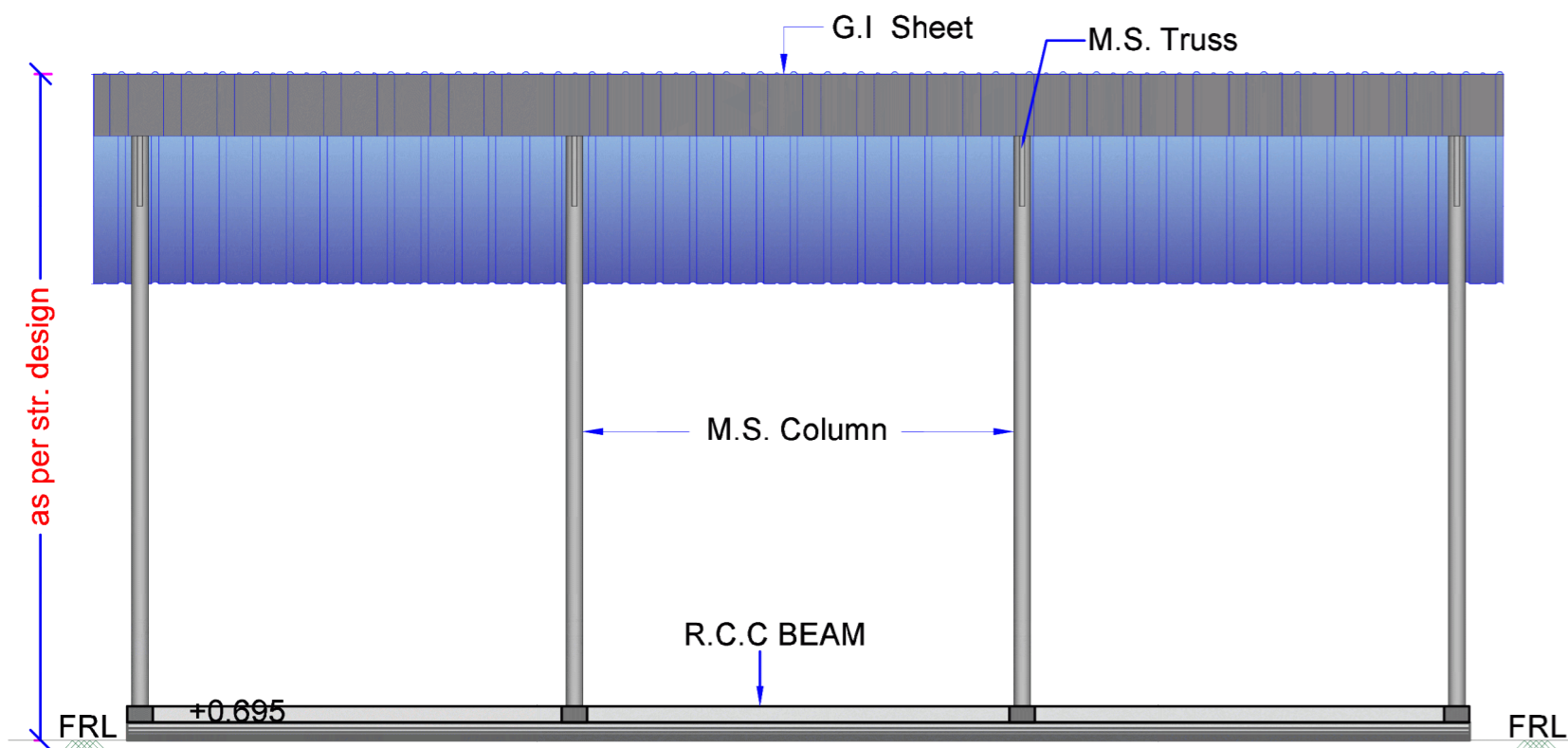

Front Elevation

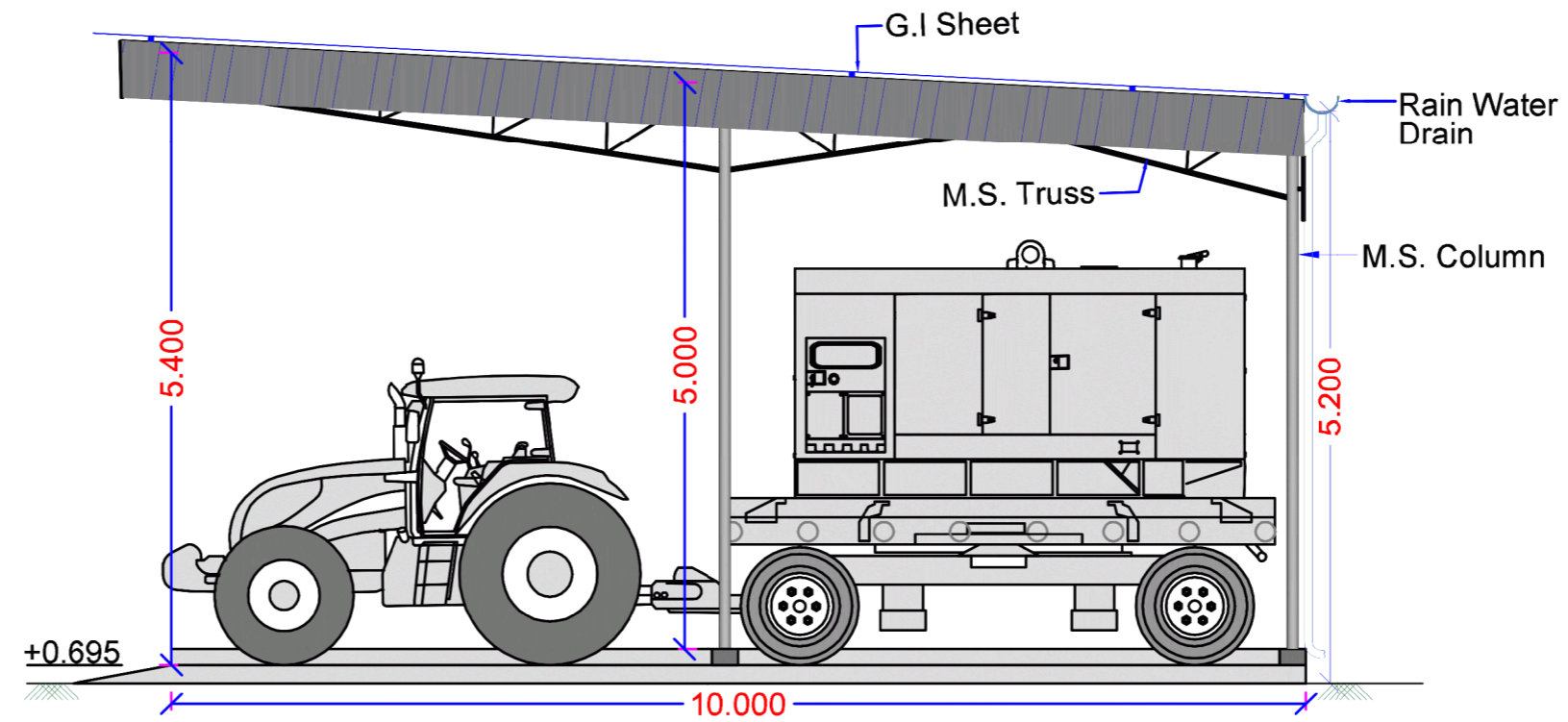

Side Elevation

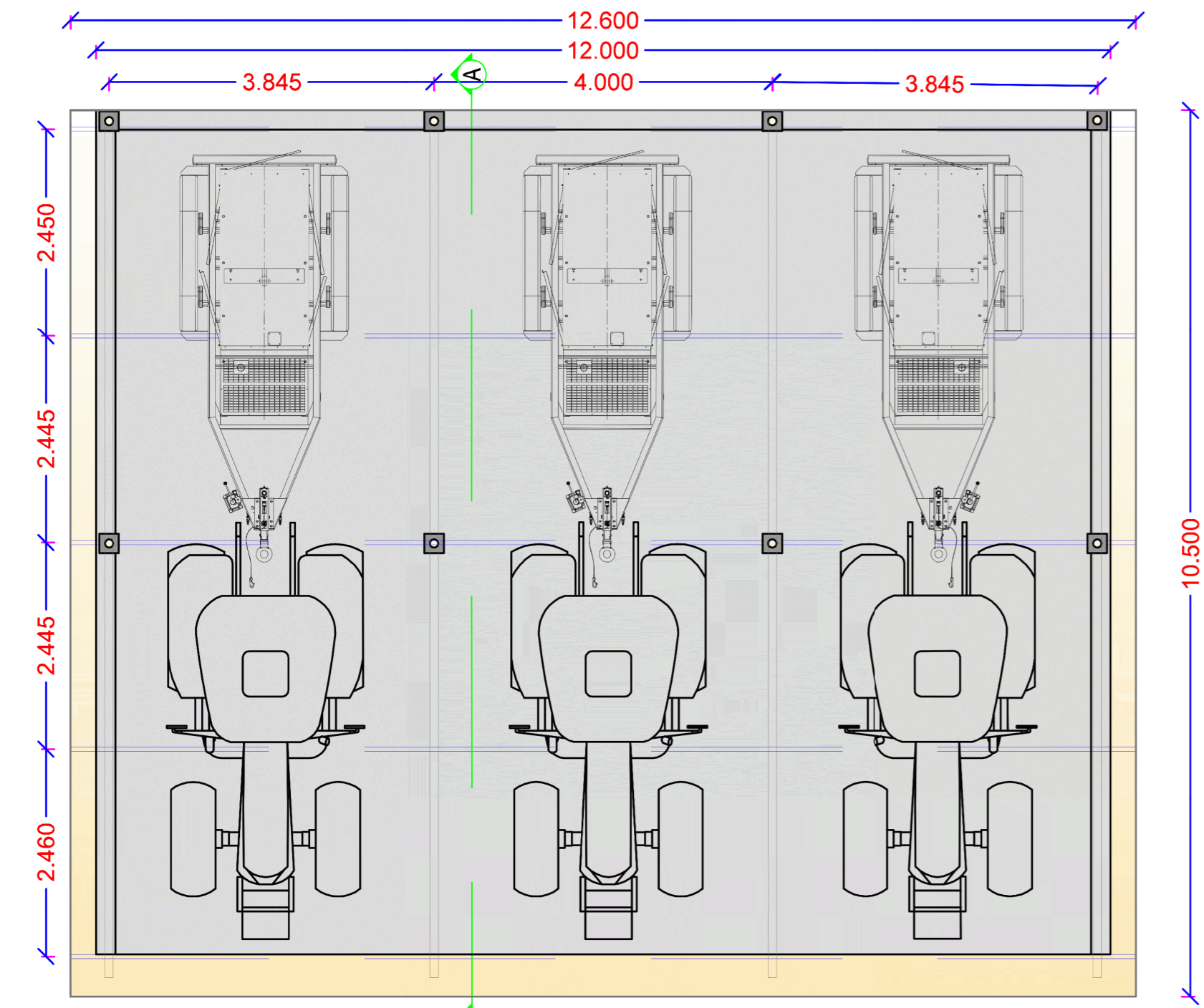

Plan  
Parking shed for tractor  
with generator trolley

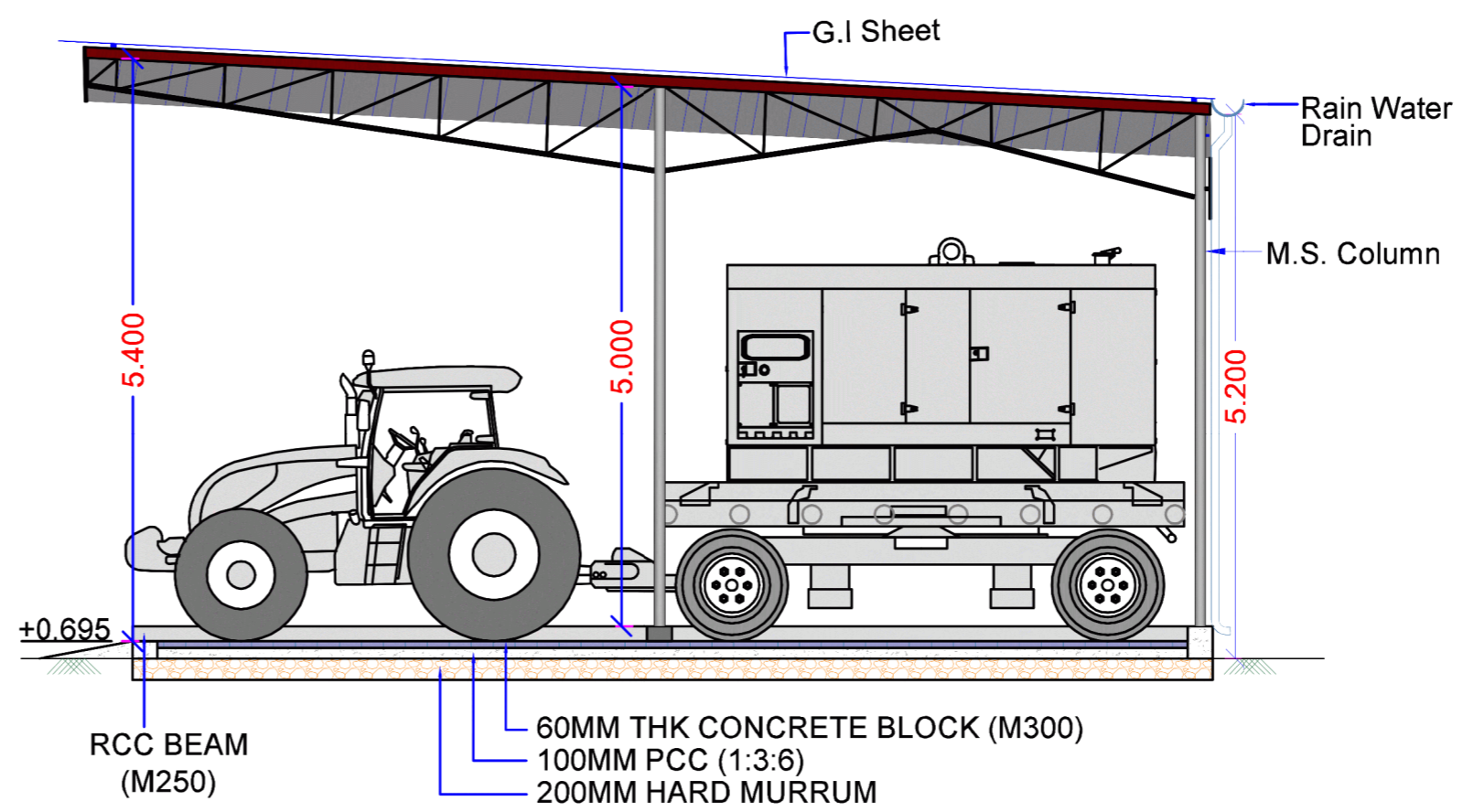

Section A-A

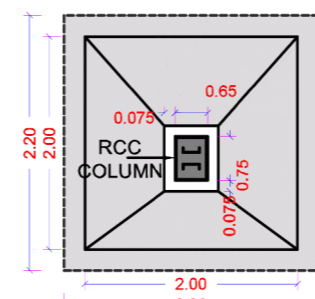

DETAILS OF FOOTING

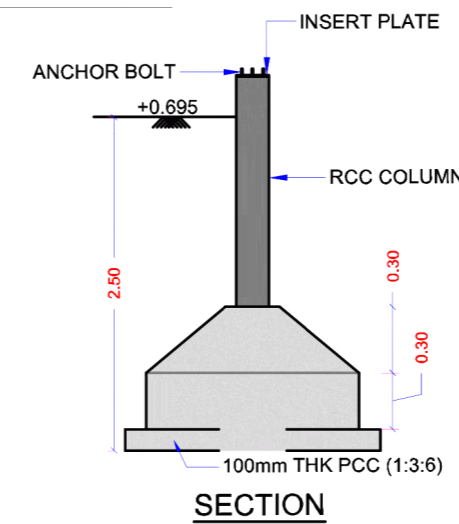

SECTION

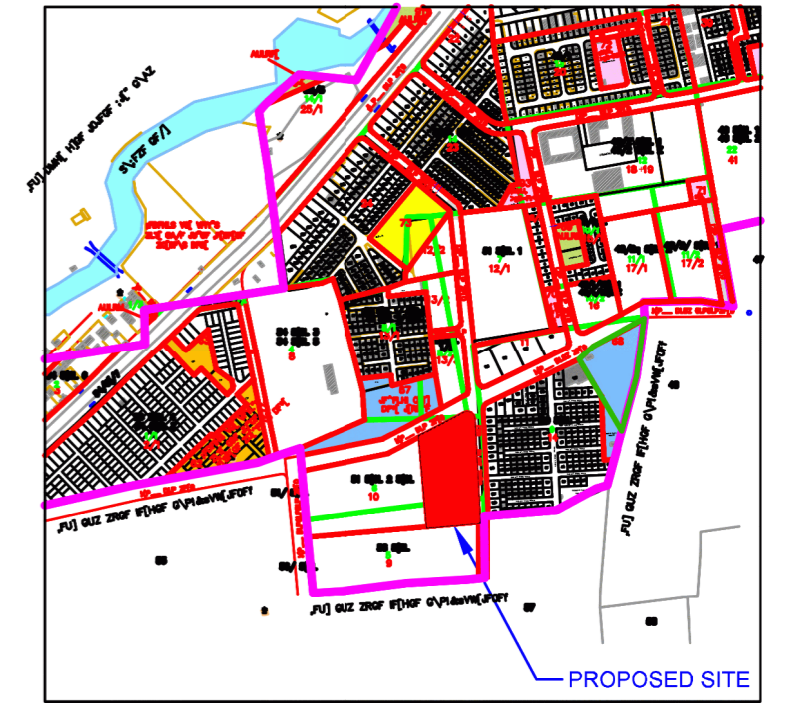

KEY PLAN

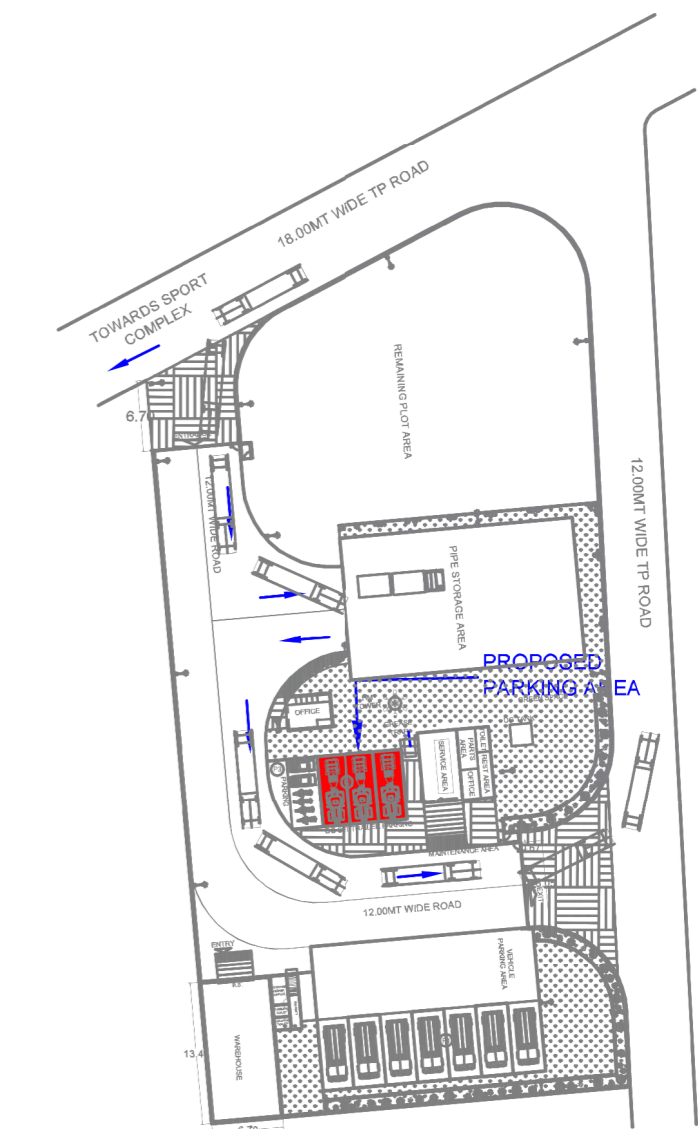

LAYOUT PLAN

TENDER DRAWING

NO	DATE	DESCRIPTION	SIGNATURE
PROJECT:- CONSULTANCY SERVICE FOR PREPARATION OF DPR, DTP AND PMC SERVICE OF SEWAGE PROJECT UNDER AMRUT 2.0 OF BHAVNAGAR CITY.			
CLIENT:- THE EXECUTIVE ENGINEER, DRAINAGE DEPARTMENT, MUNICIPAL CORPORATION, CENTRAL OFFICE BUILDING, SIR MANGALSINHJI ROAD, BHAVNAGAR- 364001			
CONSULTANT:- FACILE MAVEN PRIVATE LIMITED			
1701, 2 & 3, Rio Empire,		Ph: + 91 - 261 - 6575998	
Opp. Pal RTO, Pal, Surat - 395009		Fax: + 91 - 261 - 2733584	
Email: infra@facilemaven.com			

TITLE:- DETAILS OF PARKING SHED FOR TRACTOR GENERATOR			
DRAWN BY :-	DHAIRYA	DESIGNED BY :-	PURVA
CHECKED BY :-	A.K. GARG	PROJ. NO. :-	-
SCALE :-	N.T.S	DRG. NO. :-	BMC/DSA/14
DATE :-	18/11/2024	REVISION :-	R0



# DETAILS OF UG TANK

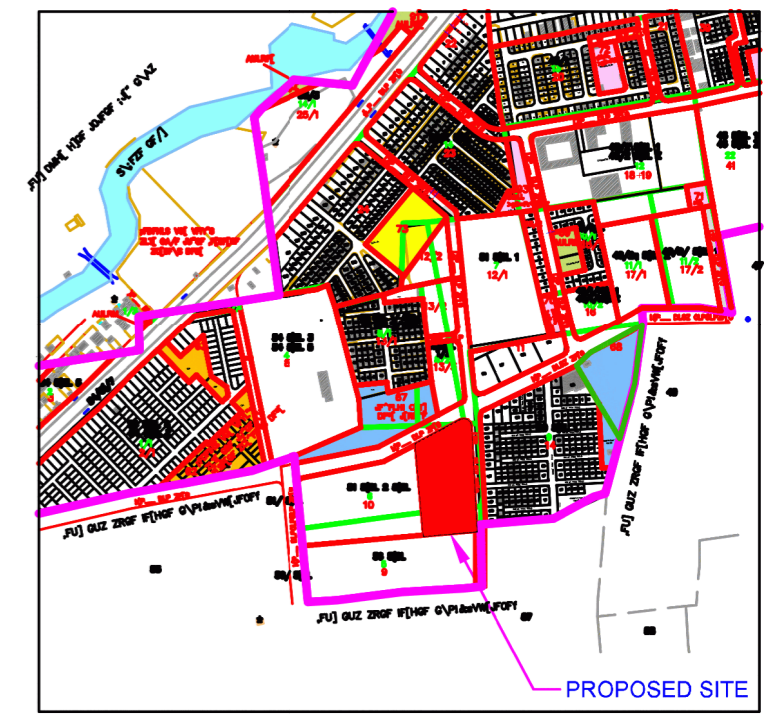
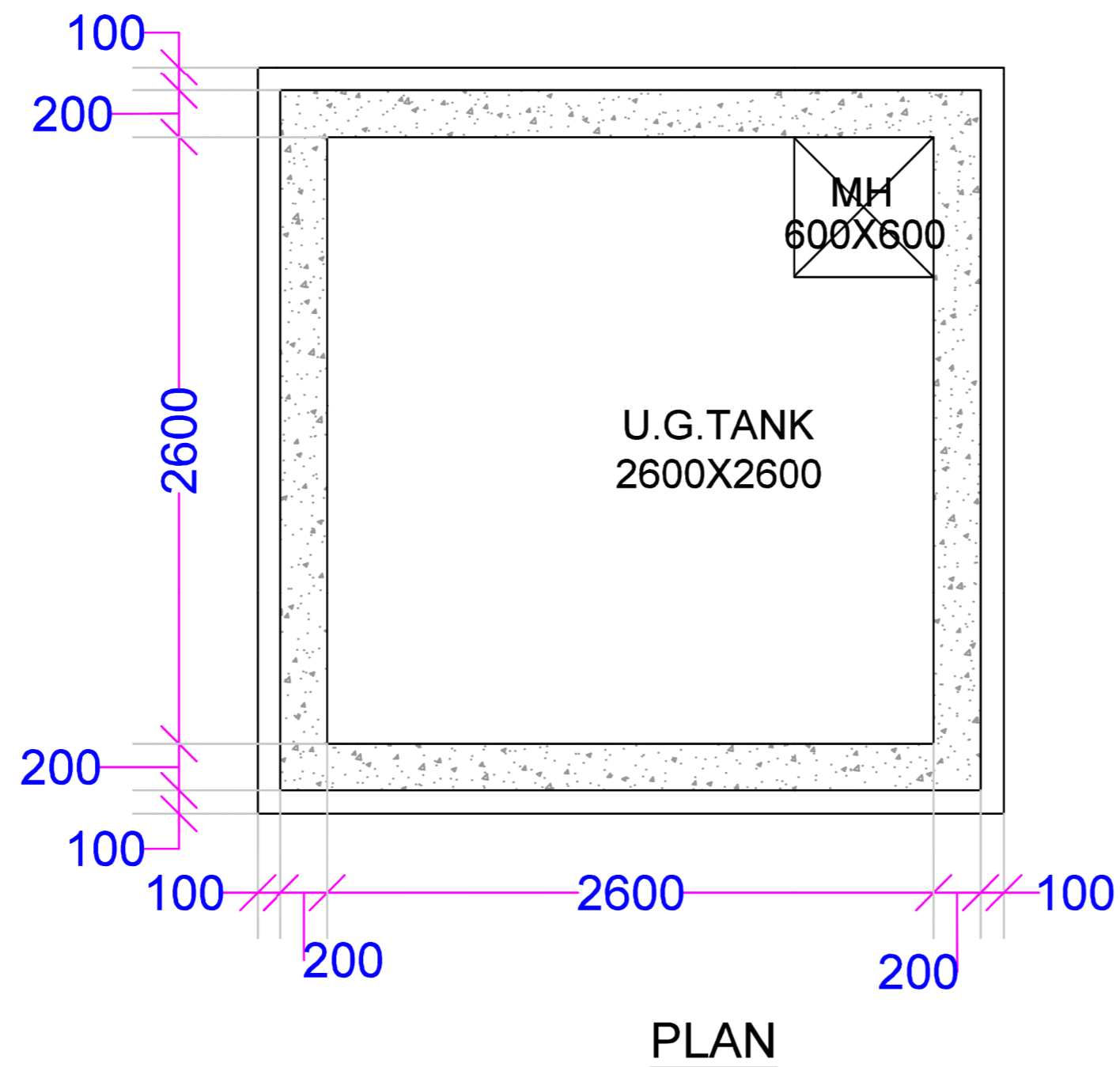
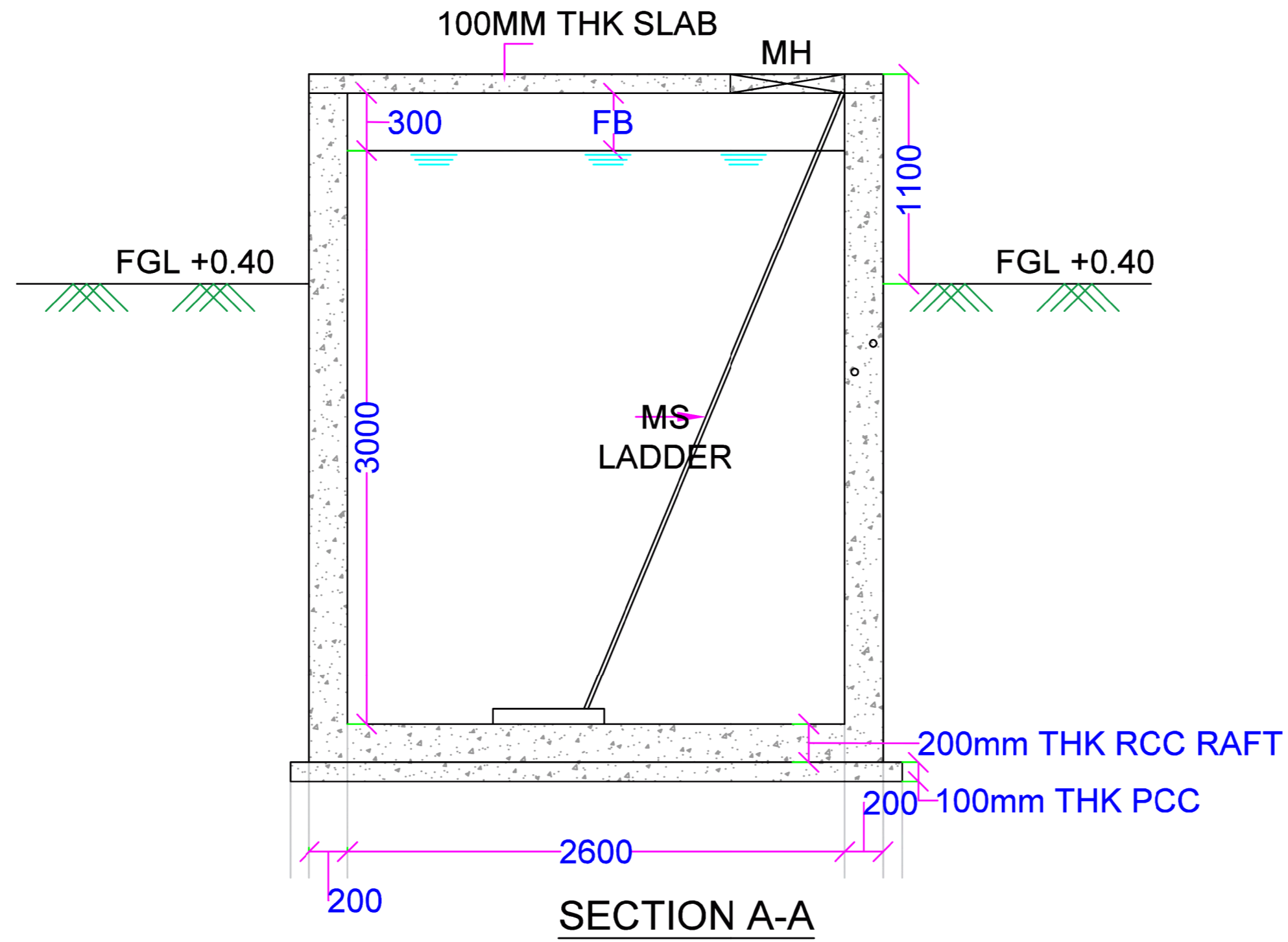

KEY PLAN

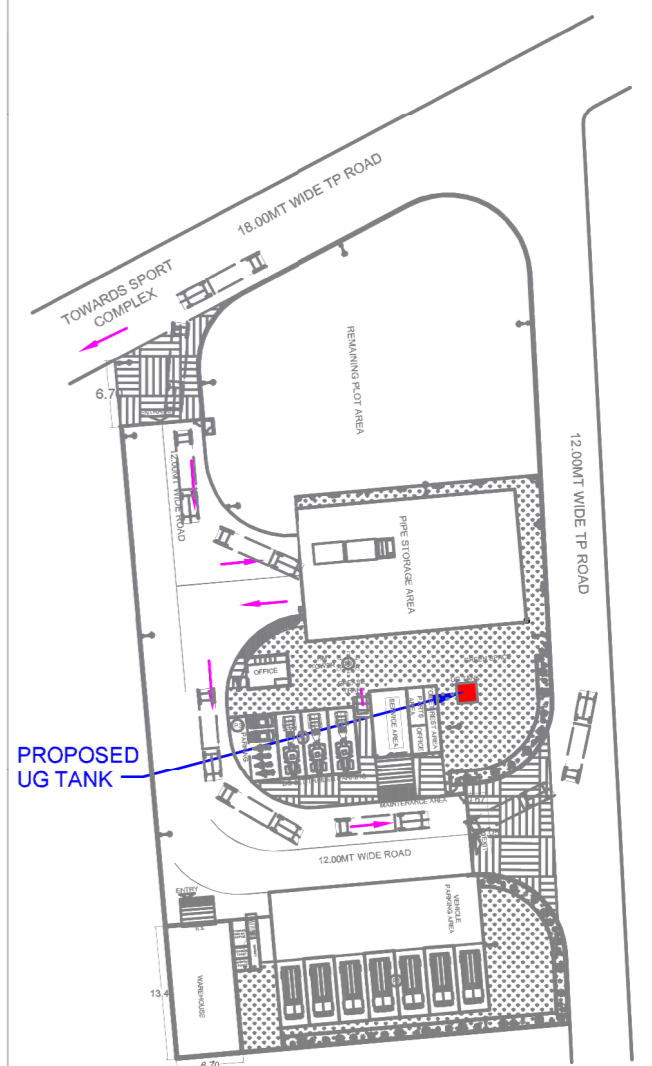

LAYOUT PLAN

## TENDER DRAWING

NO	DATE	DESCRIPTION	SIGNATURE
PROJECT:- CONSULTANCY SERVICE FOR PREPARATION OF DPR, DTP AND PMC SERVICE OF SEWRAGE PROJECT UNDER AMRUT 2.0 OF BHAVNAGAR CITY.			
CLIENT:- THE EXECUTIVE ENGINEER, DRAINAGE DEPARTMENT, MUNICIPAL CORPORATION, CENTRAL OFFICE BUILDING, SIR MANGALSINHJI ROAD, BHAVNAGAR- 364001			
CONSULTANT:- FACILE MAVEN PRIVATE LIMITED 1701, 2 & 3, Rio Empire, Ph: + 91 - 261 - 6575998 Opp. Pal RTO, Pal, Surat - Fax : + 91 - 261 - 2733584 395009 Email : infra@facilemaven.com			
TITLE:- GENERAL ARRANGEMENT DRAWING OF UG TANK			
DRAWN BY :-	AKSHAY	DESIGNED BY :-	PURVA
CHECKED BY :-	A.K.GARG	PROJ. NO. :-	-
SCALE :-	N.T.S	DRG. NO. :-	BMC/DSA/15
DATE :-	18/11/2024	REVISION :-	R0



# FLOORING DETAILS OF MAINTENANCE AREA

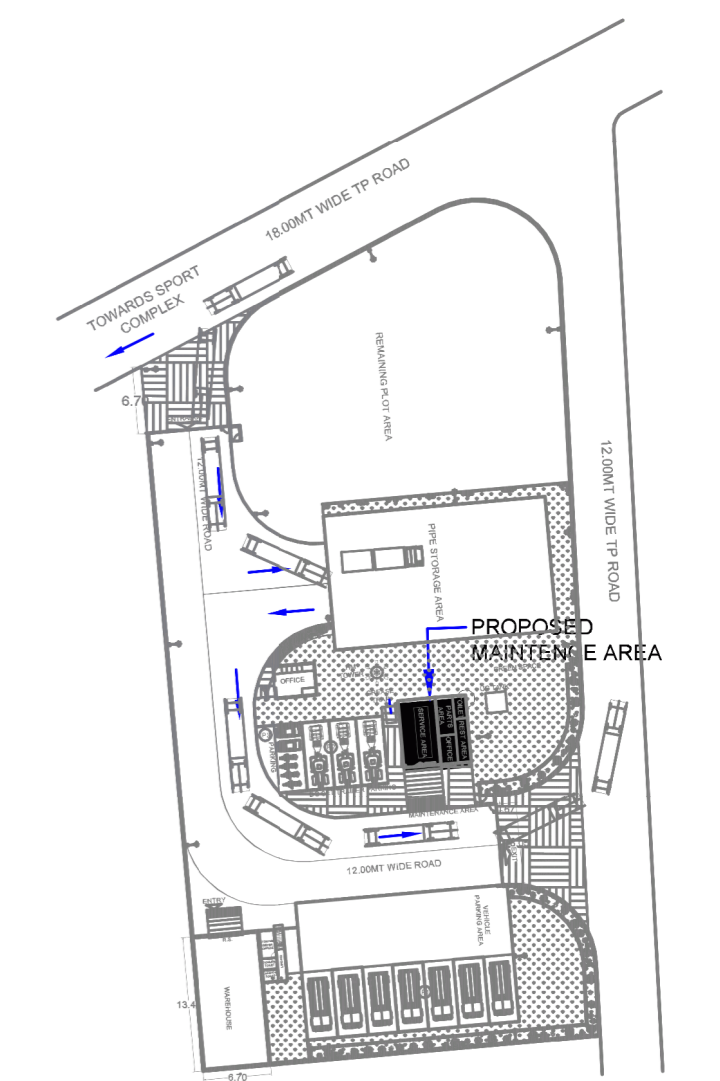
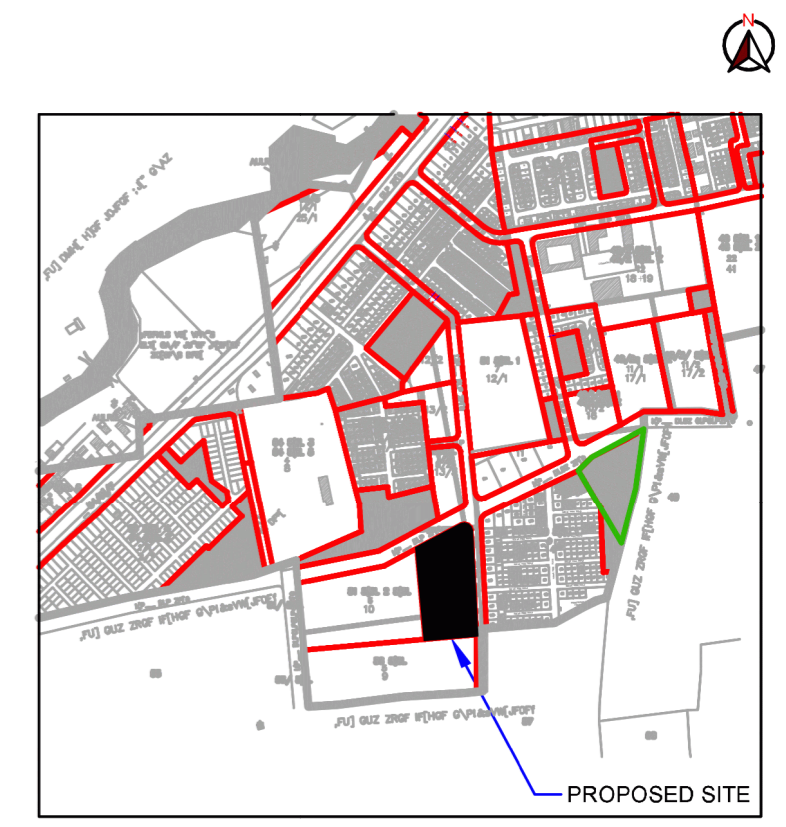
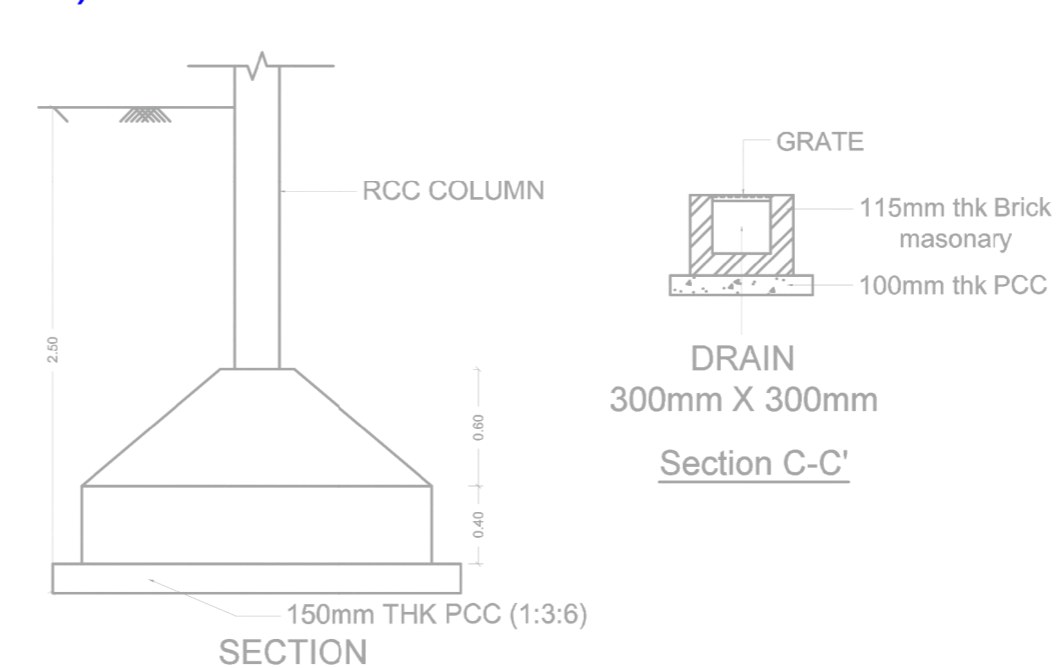
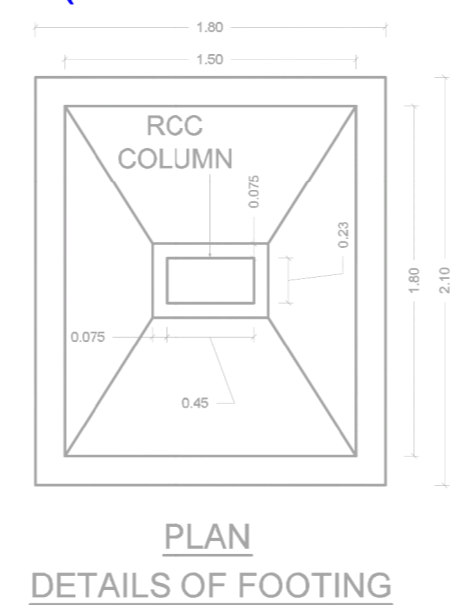
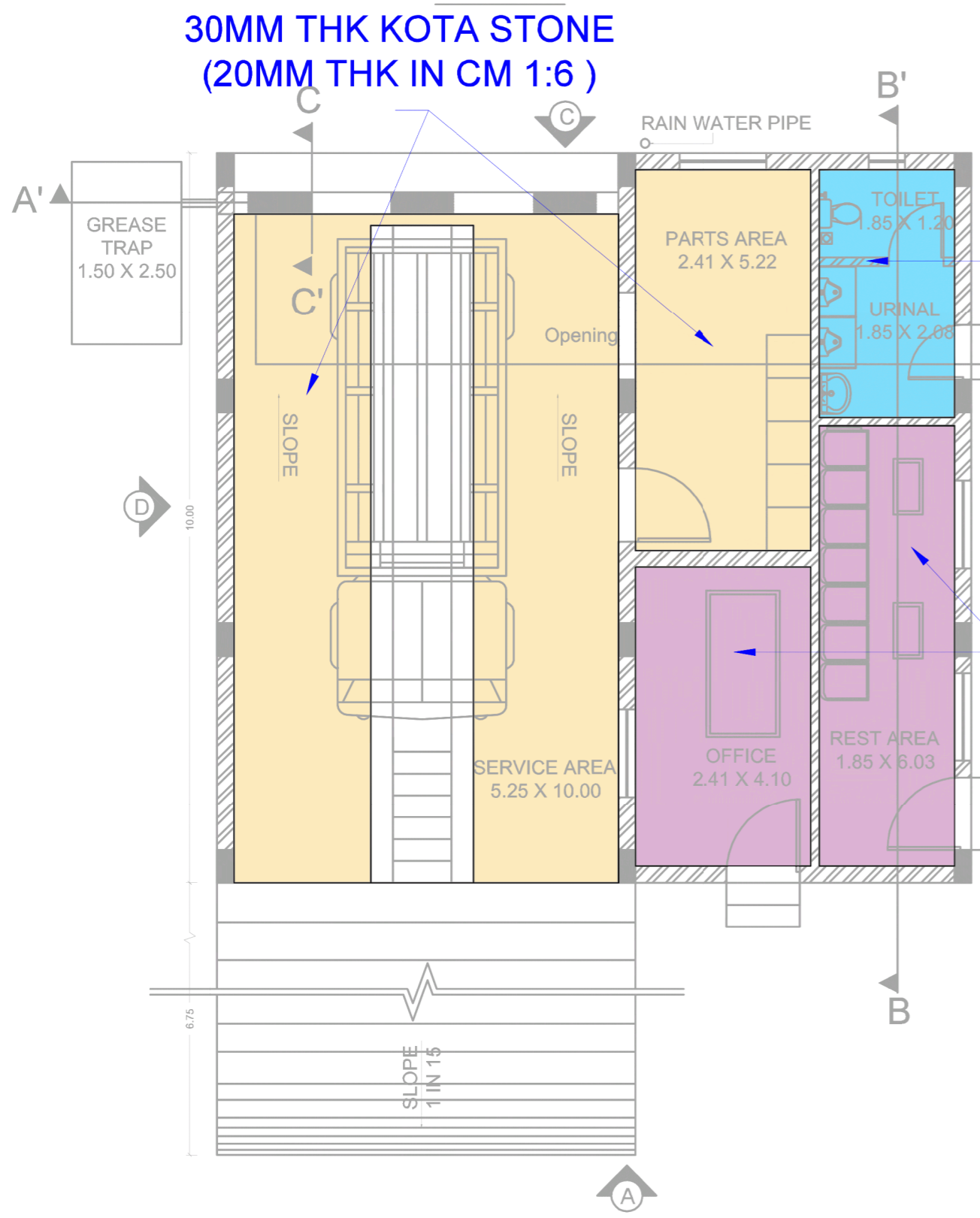
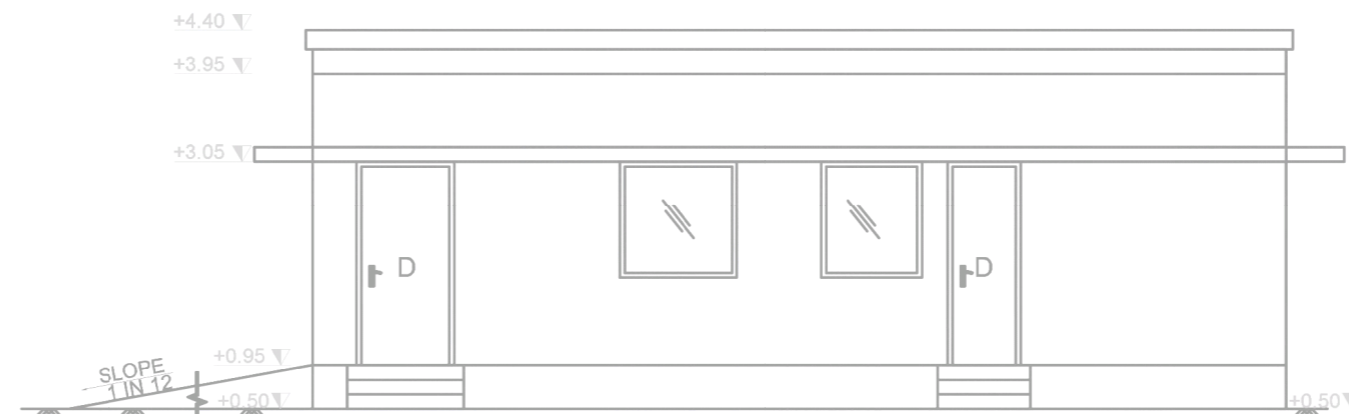
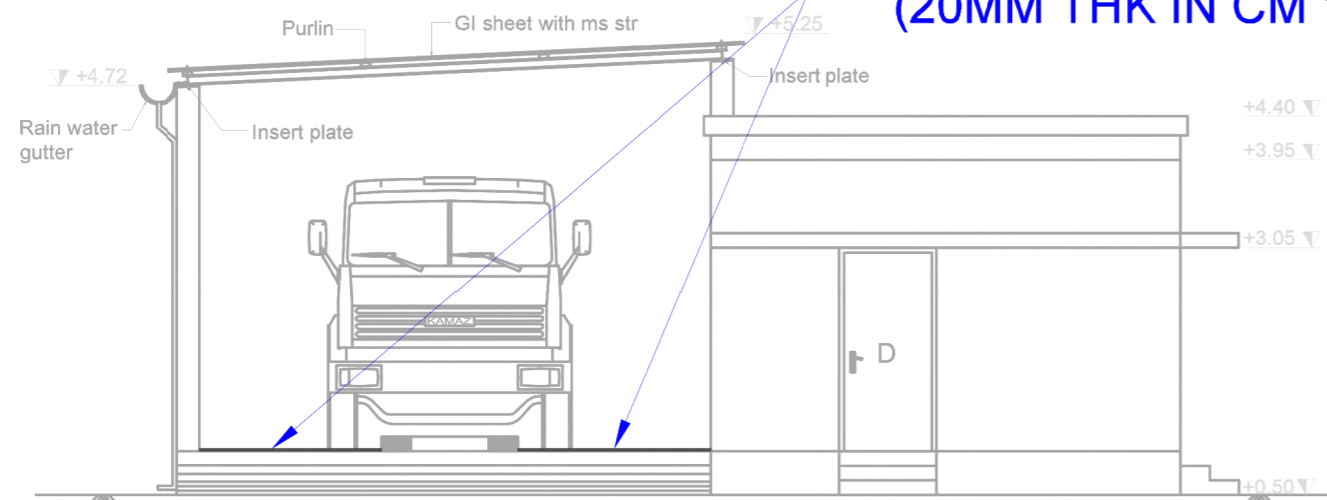
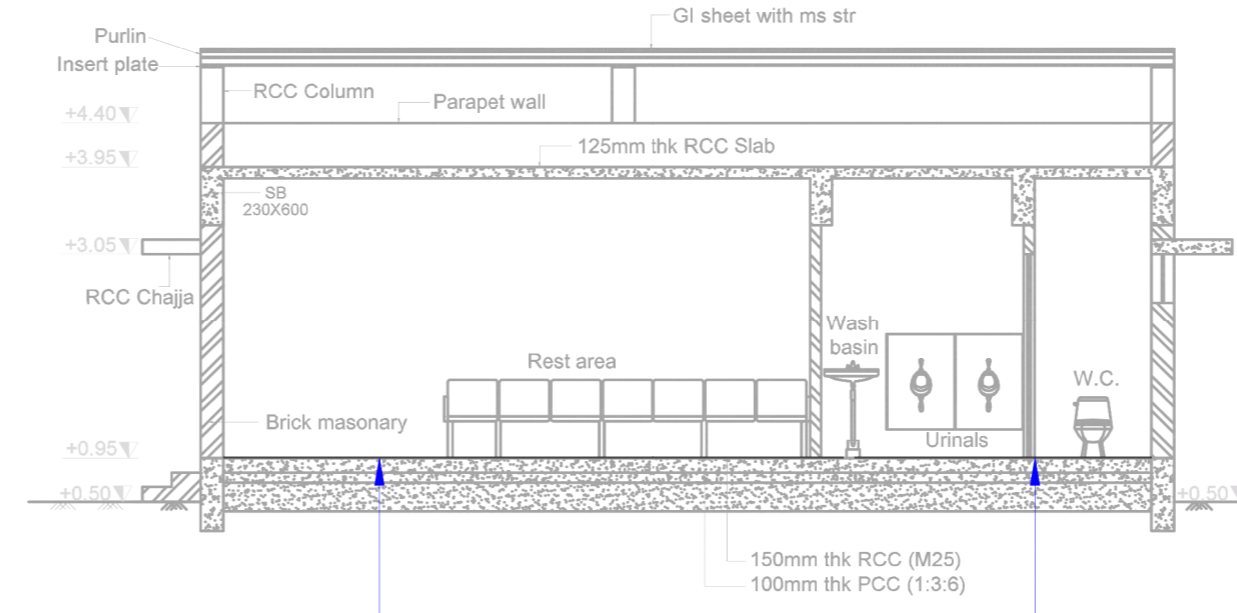
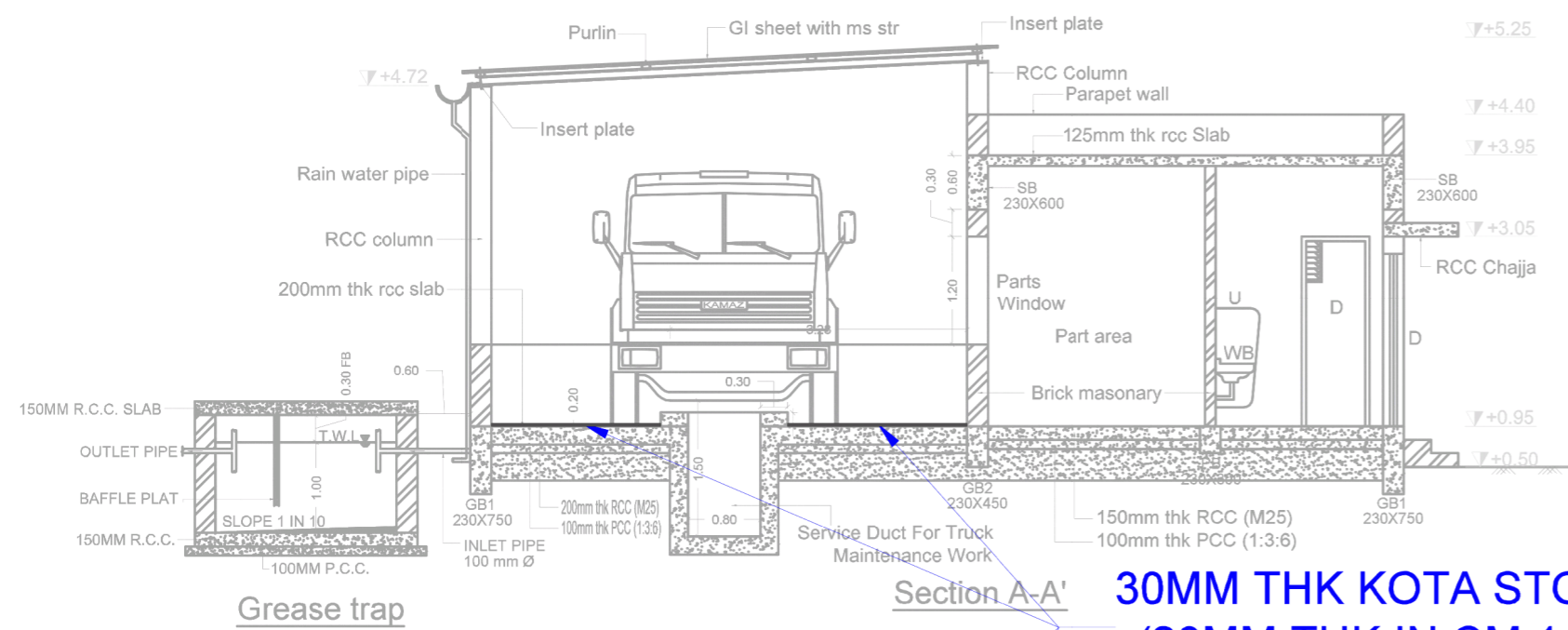

## TENDER DRAWING

NO	DATE	DESCRIPTION	SIGNATURE
PROJECT:- CONSULTANCY SERVICE FOR PREPARATION OF DPR, DTP AND PMC SERVICE OF SEWAGE PROJECT UNDER AMRUT 2.0 OF BHAVNAGAR CITY.			
CLIENT:- THE EXECUTIVE ENGINEER, DRAINAGE DEPARTMENT, MUNICIPAL CORPORATION, CENTRAL OFFICE BUILDING, SIR MANGALSINHJI ROAD, BHAVNAGAR- 364001			
CONSULTANT:- FACILE MAVEN PRIVATE LIMITED			
		1701, 2 & 3, Rio Empire, Ph: + 91 - 261 - 6575998 Opp. Pal RTO, Pal, Surat - Fax: + 91 - 261 - 2733584 395009 Email: infra@facilemaven.com	
TITLE:- FLOORING DETAILS OF MAINTENANCE AREA			

DRAWN BY :-	VIJAY	DESIGNED BY :-	PURVA
CHECKED BY :-	A.K. GARG	PROJ. NO. :-	-
SCALE :-	N.T.S	DRG. NO. :-	BMC/DSA/16
DATE :-	18/11/2024	REVISION :-	R0



# FLOORING DETAILS OF STORE KEEPER AREA, COMMON TOILET, HANDICAP TOILET AND RAMP

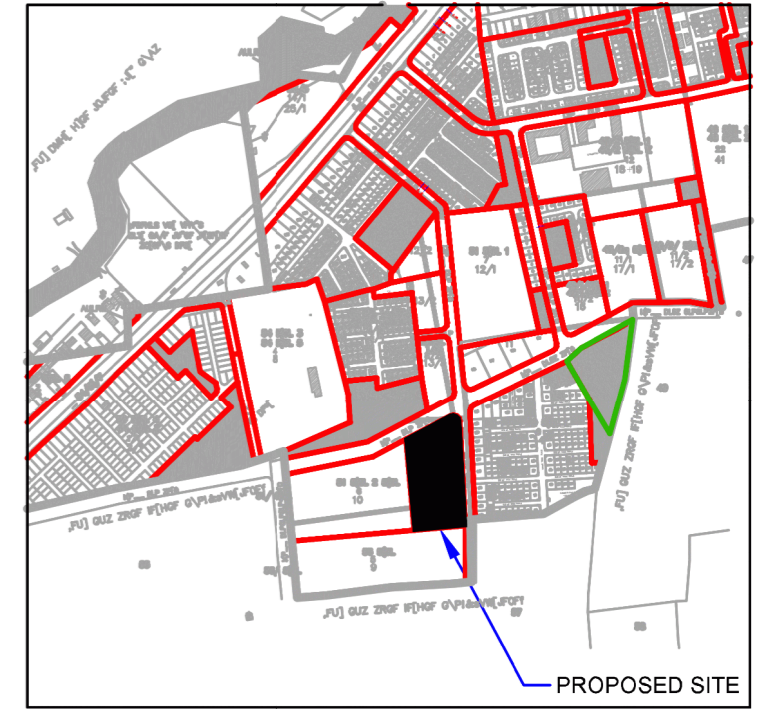

KEY PLAN

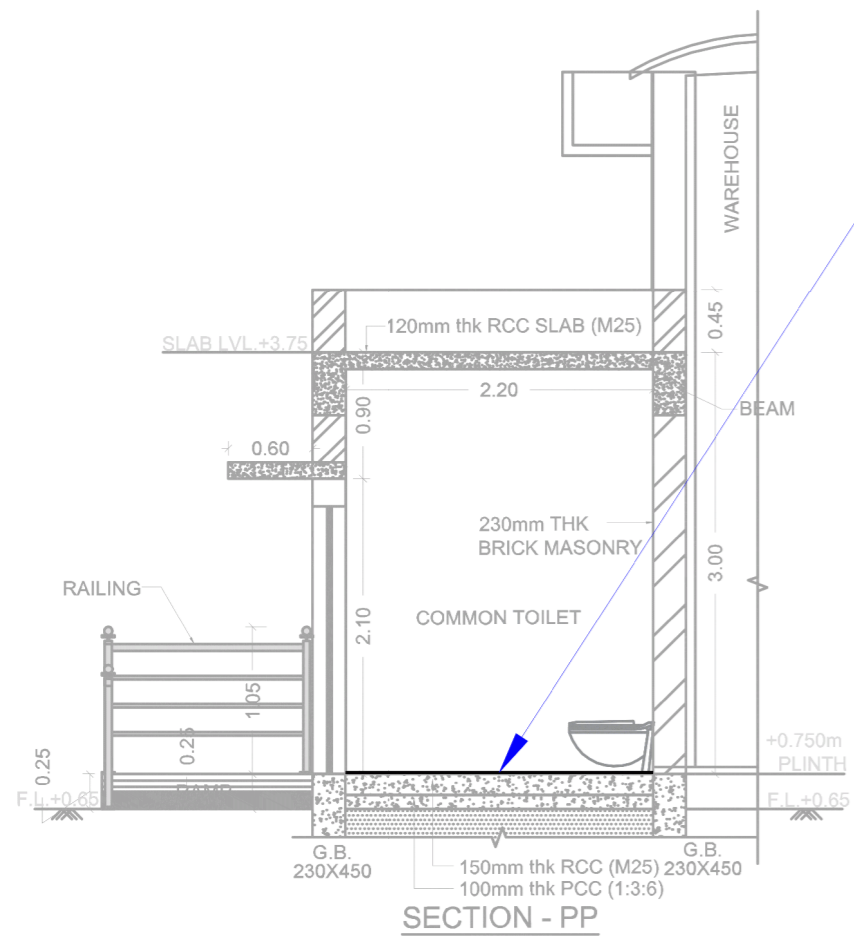

SECTION - PP

6MM THK WHITE GLAZE TILES  
(12MM THK IN CM 1:3)

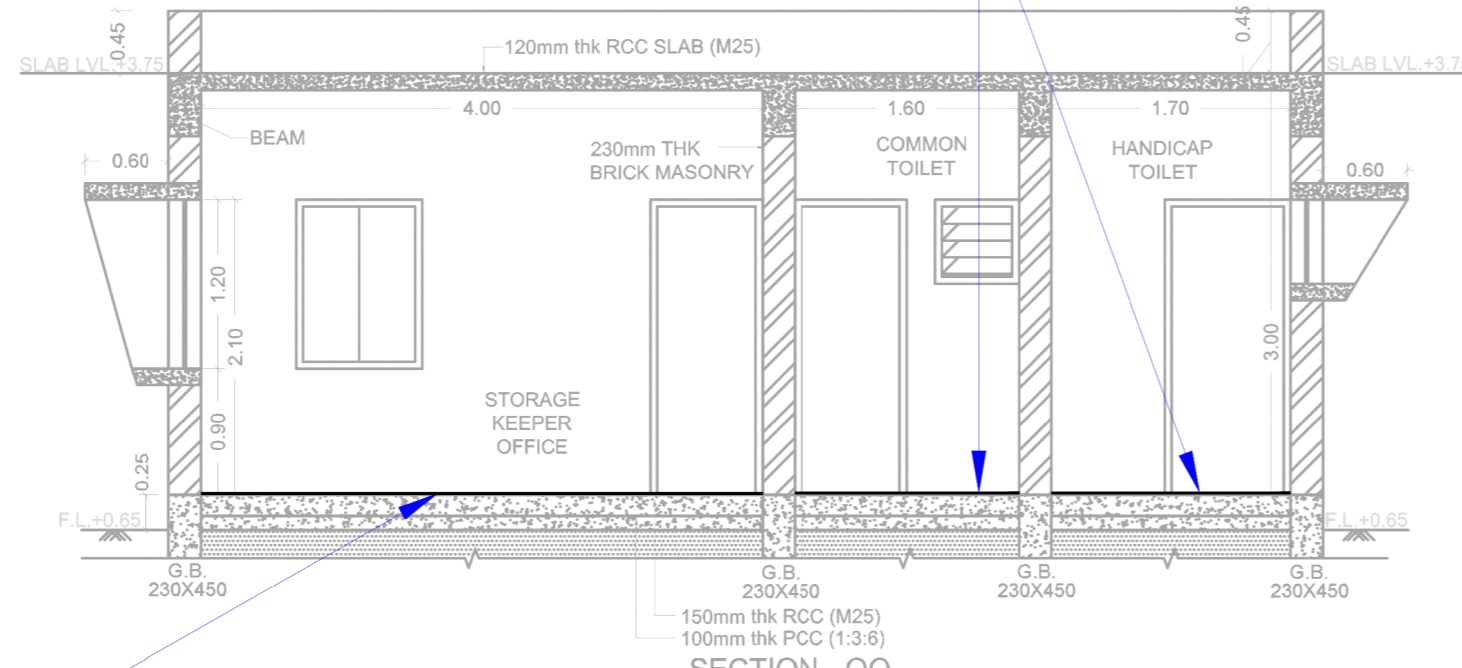

SECTION - QQ

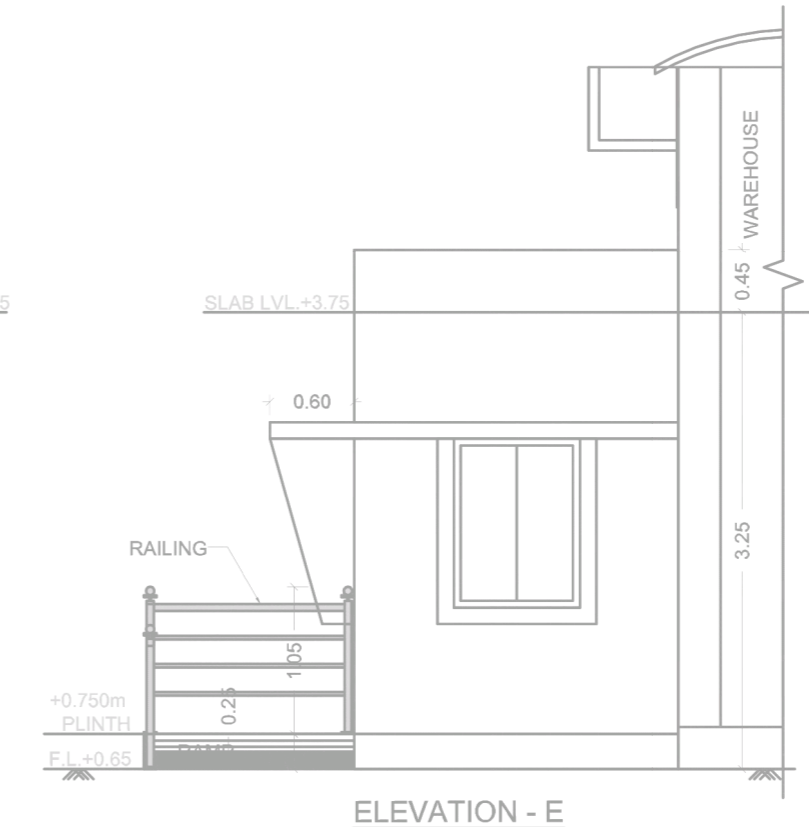

ELEVATION - E

6MM THK WHITE GLAZE TILES  
(12MM THK IN CM 1:3)

25MM THK KOTA STONE  
(20MM THK IN CM 1:6)

6MM THK CERAMIC TILES  
(12MM THK IN CM 1:3)

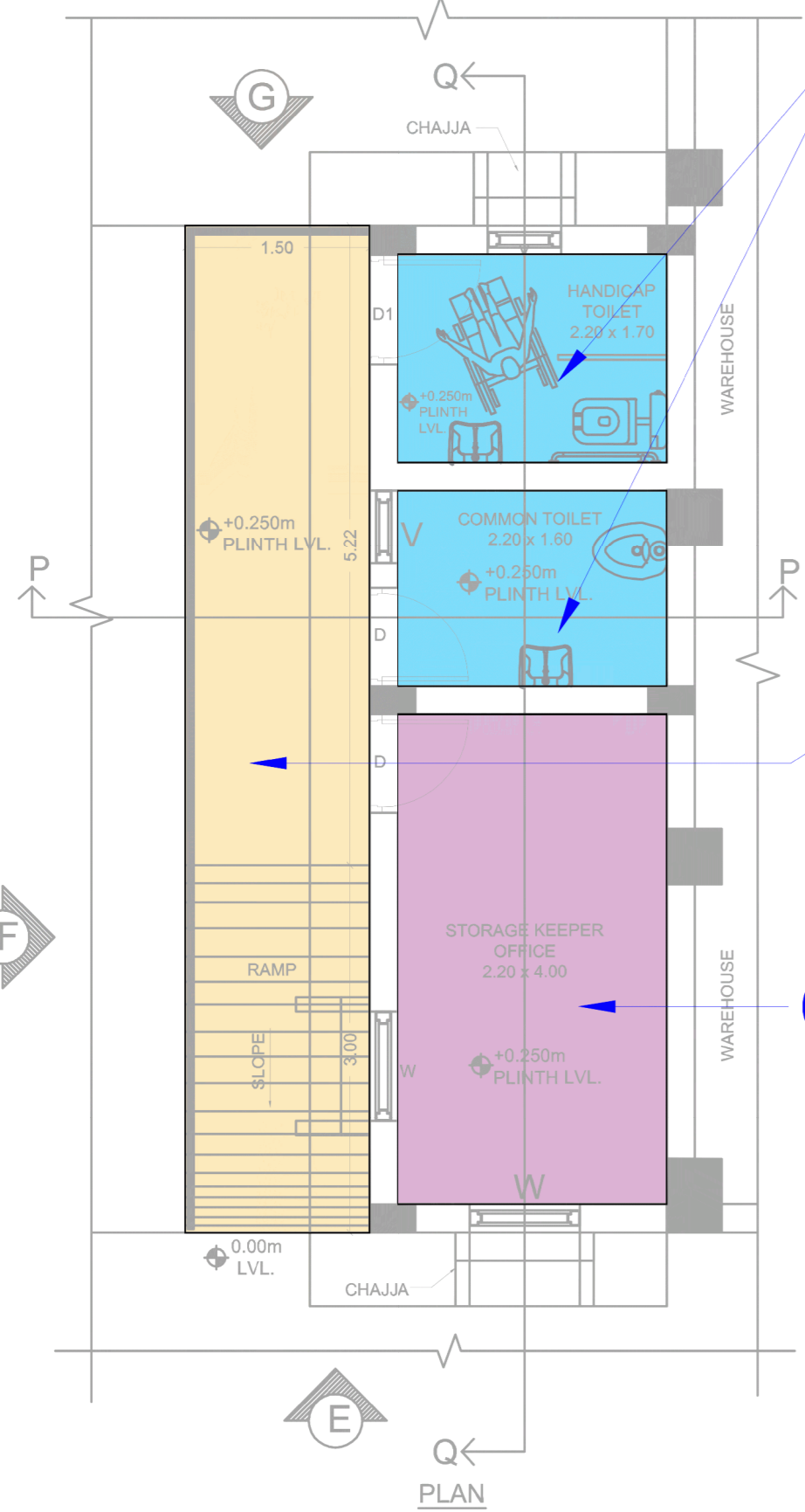

PLAN

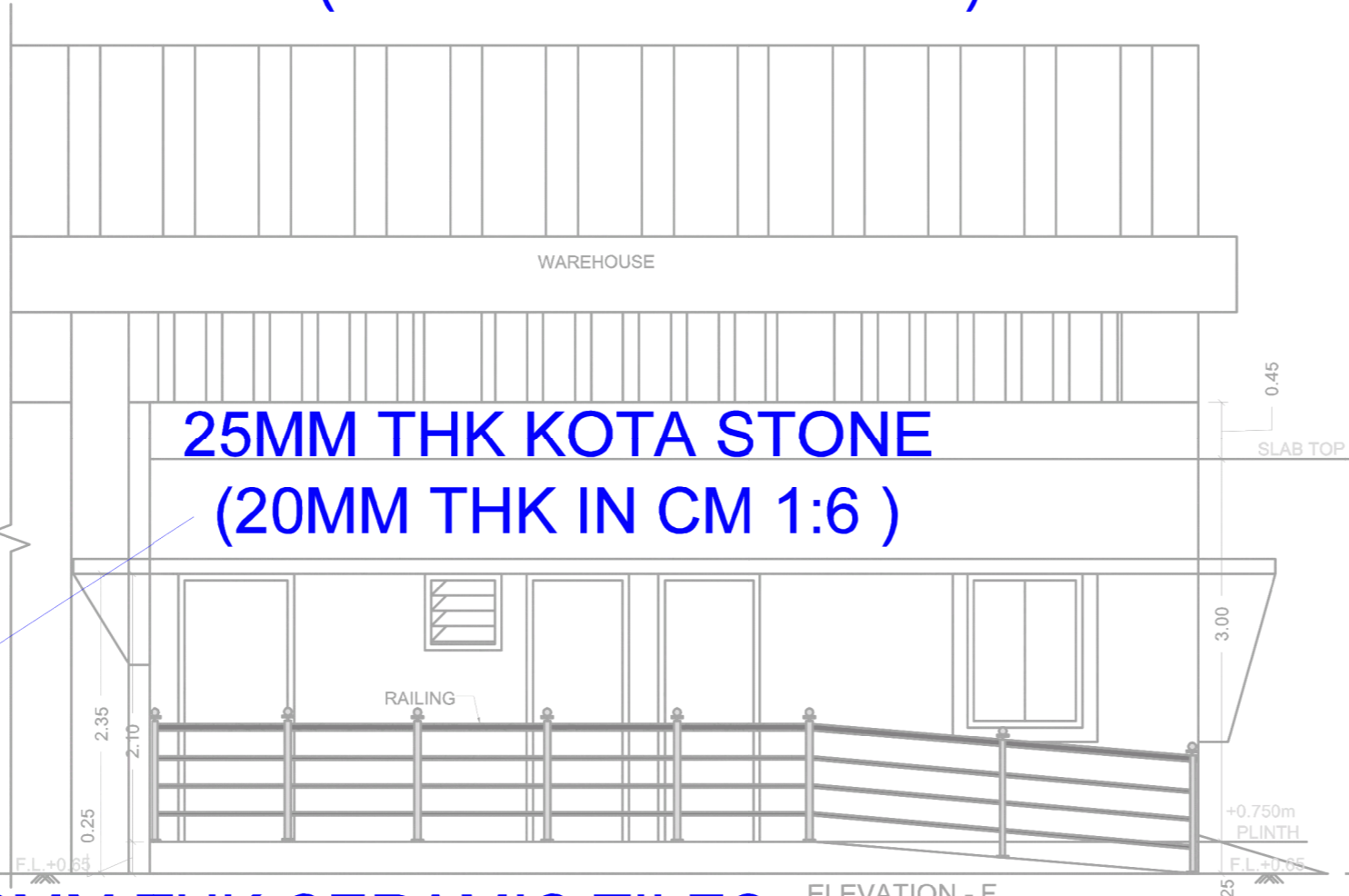

ELEVATION - F

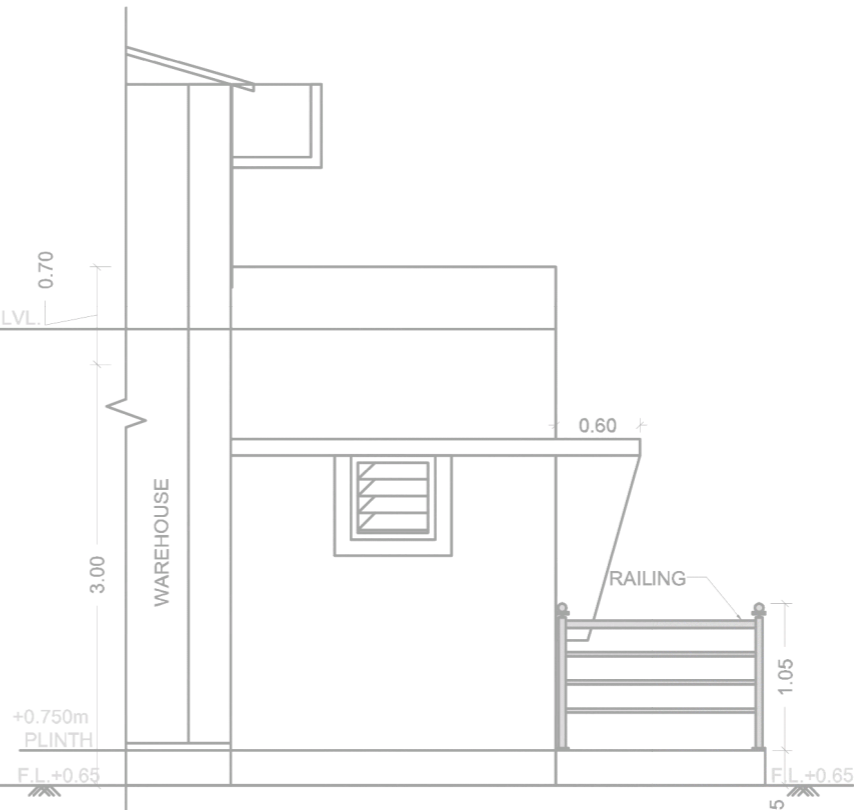

ELEVATION - G

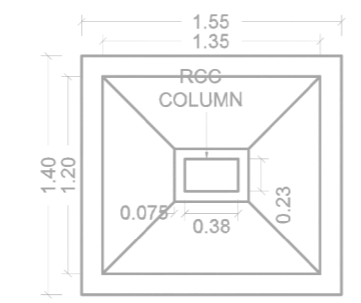

PLAN DETAILS OF FOOTING

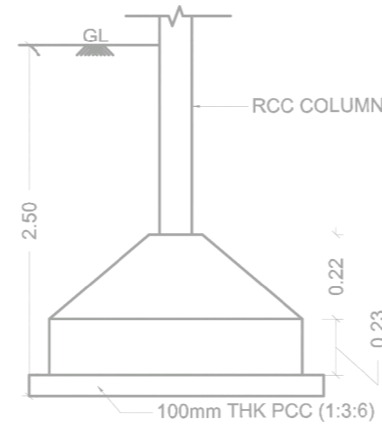

SECTION

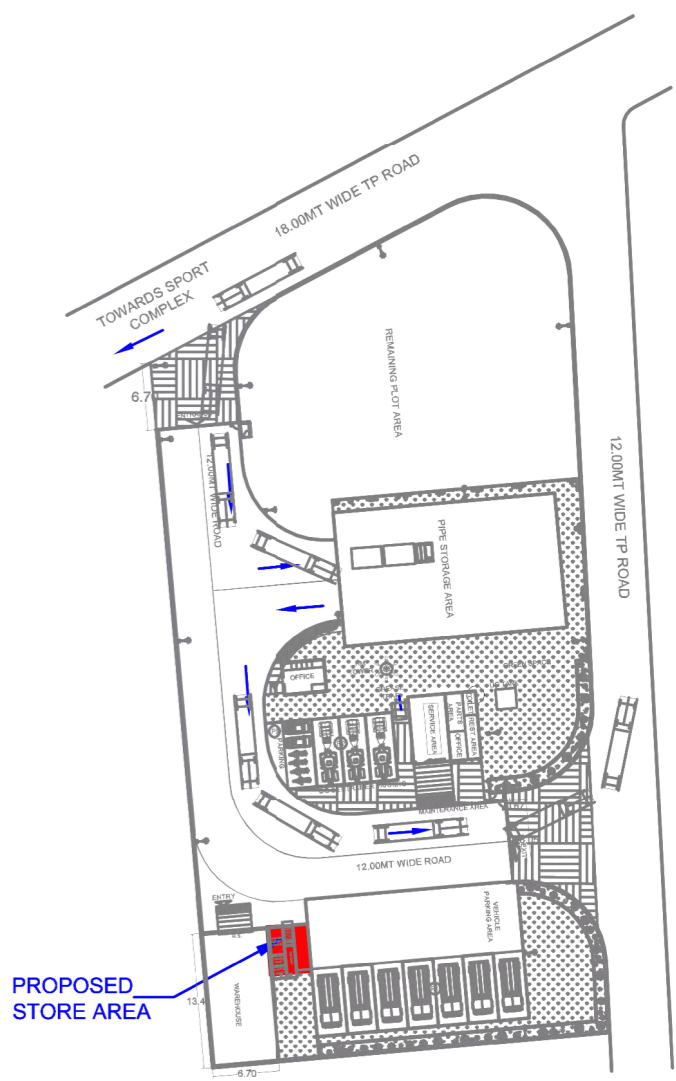

LAYOUT PLAN

## TENDER DRAWING

NO	DATE	DESCRIPTION	SIGNATURE
PROJECT:- CONSULTANCY SERVICE FOR PREPARATION OF DPR, DTP AND PMC SERVICE OF SEWAGE PROJECT UNDER AMRUT 2.0 OF BHAVNAGAR CITY.			
CLIENT:- THE EXECUTIVE ENGINEER, DRAINAGE DEPARTMENT, MUNICIPAL CORPORATION, CENTRAL OFFICE BUILDING, SIR MANGALSINHI ROAD, BHAVNAGAR- 364001			
CONSULTANT:- FACILE MAVEN PRIVATE LIMITED 1701, 2 & 3, Rio Empire, Ph: + 91 - 261 - 6575998 Opp. Pal RTO, Pal, Surat - Fax: + 91 - 261 - 2733584 395009 Email: infra@facilemaven.com			
TITLE:- FLOORING DETAILS OF STORE KEEPER AREA, COMMON TOILET, HANDICAP TOILET AND RAMP			
DRAWN BY :-	VIJAY	DESIGNED BY :-	PURVA
CHECKED BY :-	A.K. GARG	PROJ. NO. :-	-
SCALE :-	N.T.S	DRG. NO. :-	BMC/DSA/17
DATE :-	18/11/2024	REVISION :-	R0

# TYPICAL CROSS SECTION OF CEMENT CONCRETE ROAD

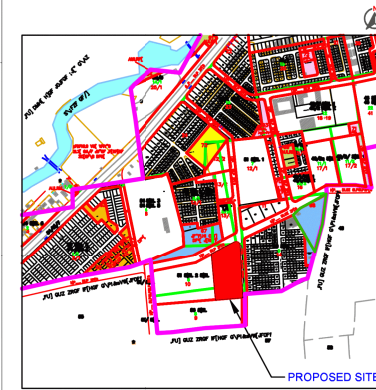
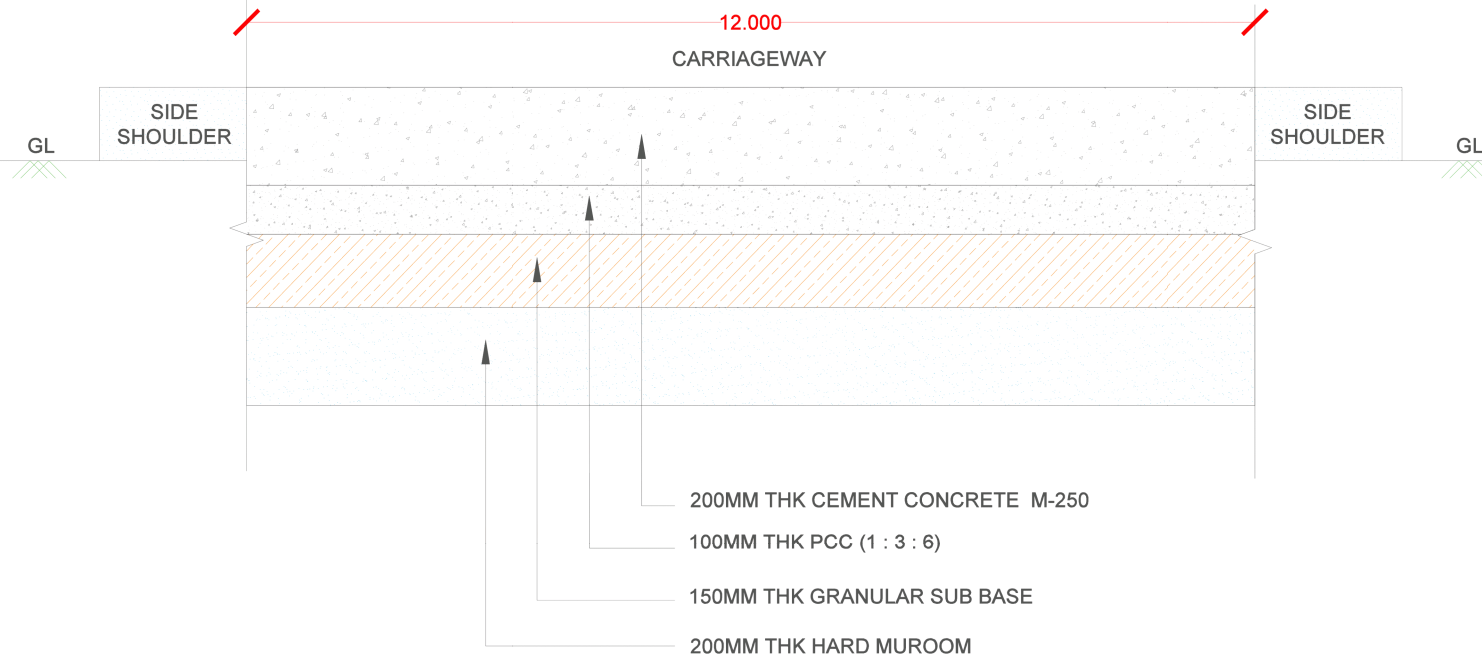

KEY PLAN

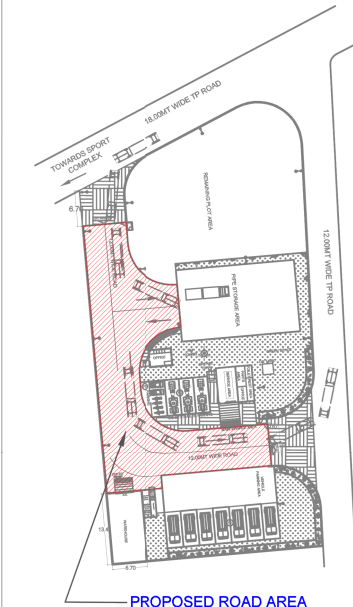

## TENDER DRAWING

NO	DATE	DESCRIPTION	SIGNATURE

PROJECT:- CONSULTANCY SERVICE FOR PREPARATION OF DPR, DTP AND PMC SERVICE OF SEWRAGE PROJECT UNDER AMRUT 2.0 OF BHAVNAGAR CITY.

CLIENT:- THE EXECUTIVE ENGINEER,  
DRAINAGE DEPARTMENT, MUNICIPAL CORPORATION,  
CENTRAL OFFICE BUILDING, SIR MANGALSINHJI ROAD,  
BHAVNAGAR- 364001

CONSULTANT:- FACILE MAVEN PRIVATE LIMITED

**facile maven**  
CONSULTANTS  
1701, 2 & 3, Rio Empire, Ph: + 91 - 261 - 6575998  
Opp. Pal RTO, Pal, Surat - Fax: + 91 - 261 - 2733584  
395009 Email: infra@facilemaven.com

TITLE:- TYPICAL CROSS SECTION OF CEMENT CONCRETE ROAD

DRAWN BY :-	AKSHAY	DESIGNED BY :-	B.K.PATEL
CHECKED BY :-	A.K.GARG	PROJ. NO. :-	-
SCALE :-	N.T.S	DRG. NO. :-	BMC/DSA/18
DATE :-	18/11/2024	REVISION :-	R0



# DETAILS OF PAVER BLOCK

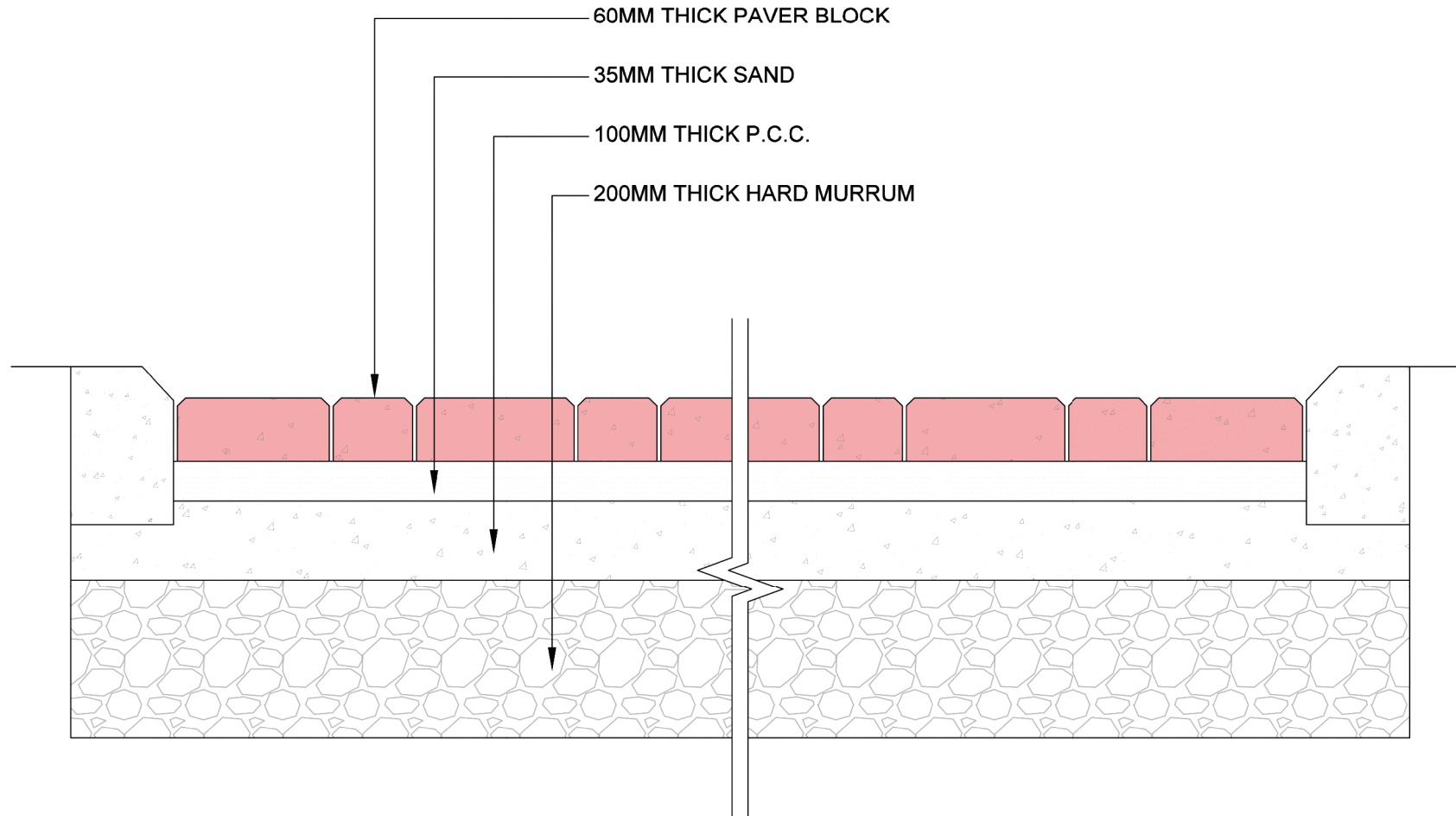

**TYPICAL CROSS SECTION OF PAVER BLOCK**

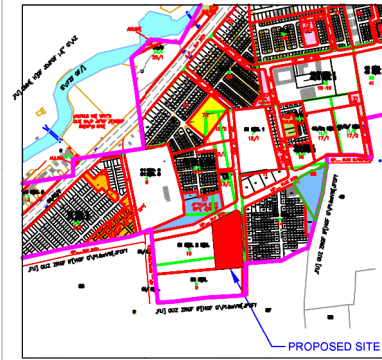

**KEY PLAN**

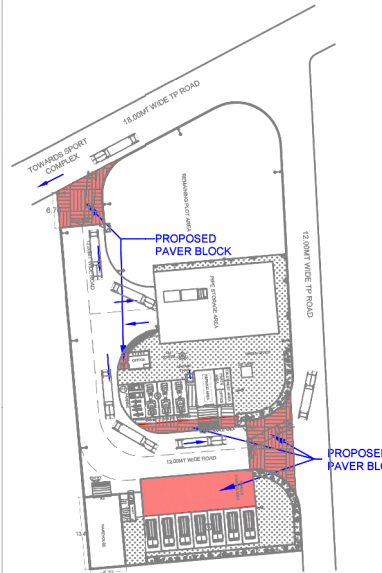

**LAYOUT PLAN**

## TENDER DRAWING

NO	DATE	DESCRIPTION	SIGNATURE
----	------	-------------	-----------

PROJECT:- CONSULTANCY SERVICE FOR PREPARATION OF DPR, DTP AND PMC SERVICE OF SEWAGE PROJECT UNDER AMRUT 2.0 OF BHAVNAGAR CITY.

CLIENT:- THE EXECUTIVE ENGINEER,  
DRAINAGE DEPARTMENT, MUNICIPAL CORPORATION,  
CENTRAL OFFICE BUILDING, SIR MANGALSINHJI ROAD,  
BHAVNAGAR- 364001

CONSULTANT:- **FACILE MAVEN PRIVATE LIMITED**  
1701, 2 & 3, Rio Empire, Ph: + 91 - 261 - 6575998  
Opp. Pal RTO, Pal, Surat - Fax: + 91 - 261 - 2733584  
395009 Email: infra@facilemaven.com

TITLE:- DETAILS OF PAVER BLOCK

DRAWN BY :-	AKSHAY	DESIGNED BY :-	B.K.PATEL
CHECKED BY :-	A.K.GARG	PROJ. NO. :-	-
SCALE :-	N.T.S	DRG. NO. :-	BMC/DSA/19
DATE :-	18/11/2024	REVISION :-	R0

# PROPOSED SEWAGE NETWORK AND WATER SUPPLY NETWORK

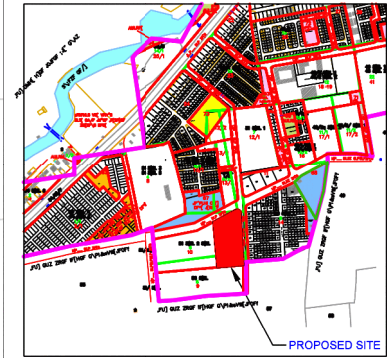

KEY PLAN

LEGEND:-

- 200MM DIA. SEWER LINE
- A- TYPE MANHOLE
- INSPECTION CHAMBER
- 25MM UPVC PIPELINE
- GREASE TRAP

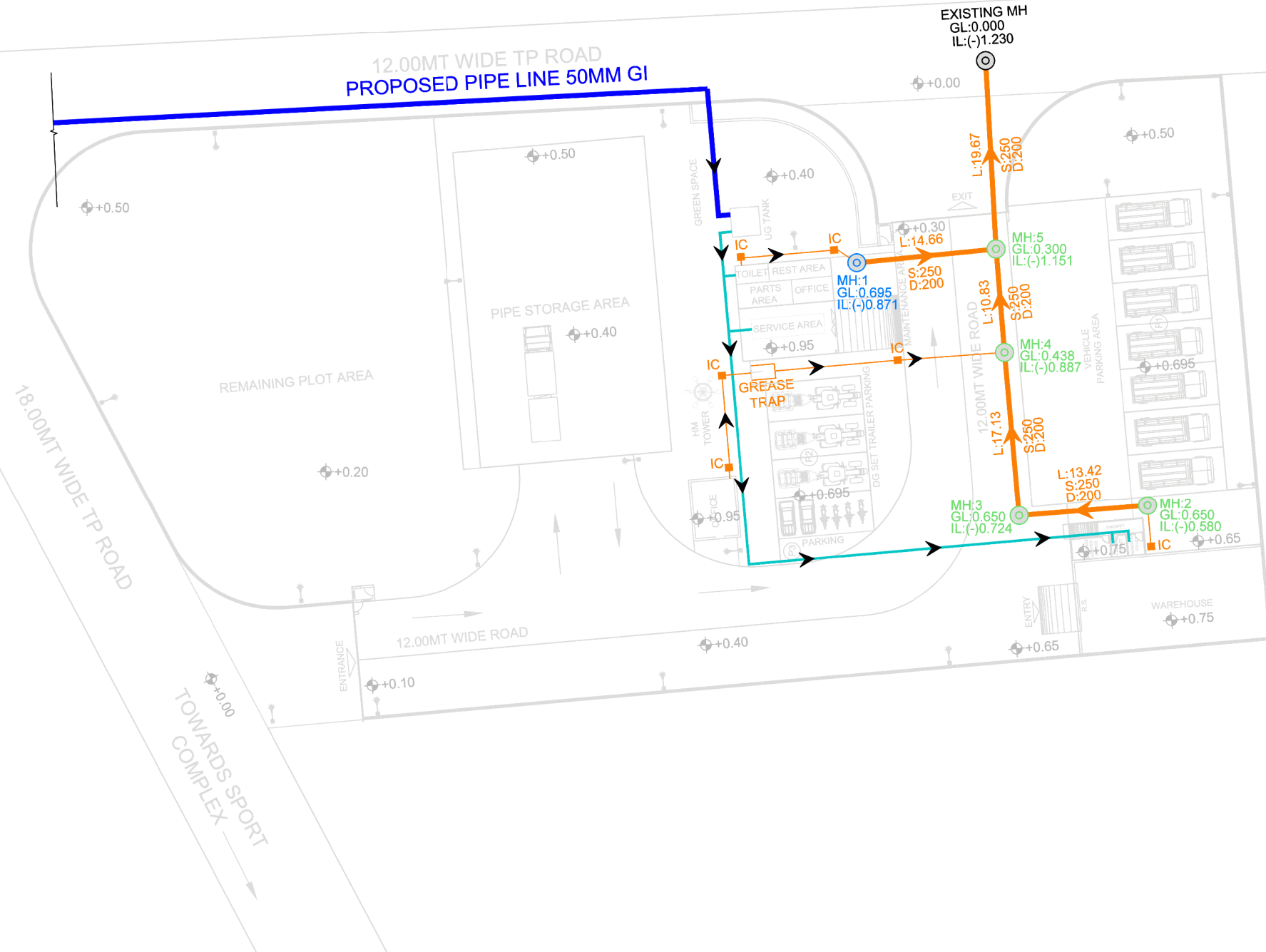

## TENDER DRAWING

NO	DATE	DESCRIPTION	SIGNATURE
PROJECT:- CONSULTANCY SERVICE FOR PREPARATION OF DPR, DTP AND PMC SERVICE OF SEWRAGE PROJECT UNDER AMRUT 2.0 OF BHAVNAGAR CITY.			
CLIENT:- THE EXECUTIVE ENGINEER, DRAINAGE DEPARTMENT, MUNICIPAL CORPORATION, CENTRAL OFFICE BUILDING, SIR MANGALSINHJI ROAD, BHAVNAGAR- 364001			
CONSULTANT:- FACILE MAVEN PRIVATE LIMITED			
		1701, 2 & 3, Rio Empire, Ph: + 91 - 261 - 6575998 Opp. Pal RTO, Pat. Surat - Fax: + 91 - 261 - 2733584 395009 Email : infra@facilemaven.com	
TITLE:- PROPOSED SEWAGE NETWORK AND WATER SUPPLY NETWORK			
DRAWN BY :-	AKSHAY	DESIGNED BY :-	PURVA
CHECKED BY :-	A.K.GARB	PROJ. NO. :-	-
SCALE :-	N.T.S	DRG. NO. :-	BMC/DSA/20
DATE :-	18/11/2024	REVISION :-	R0



# TYPICAL DETAILS OF INSPECTION CHAMBER

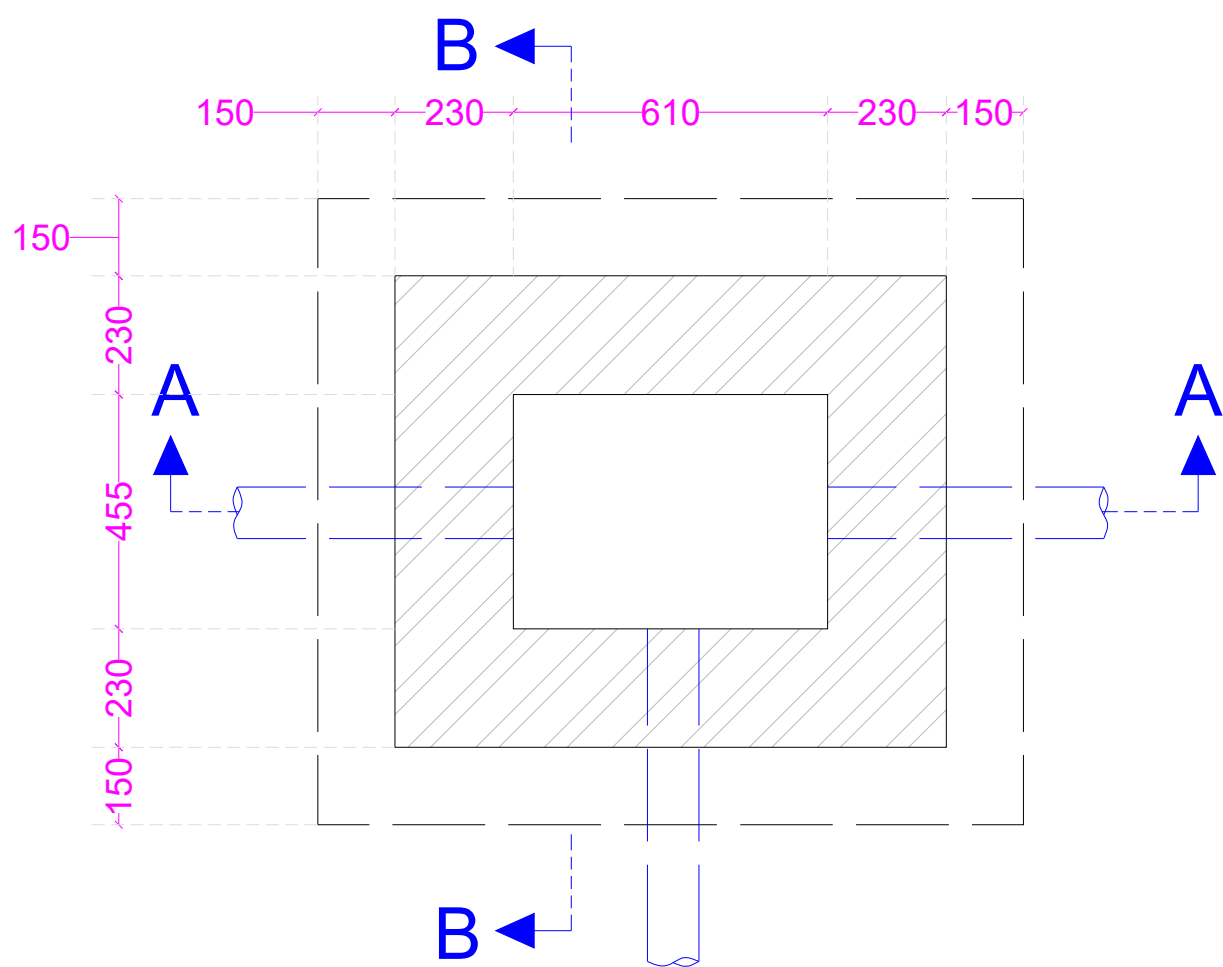
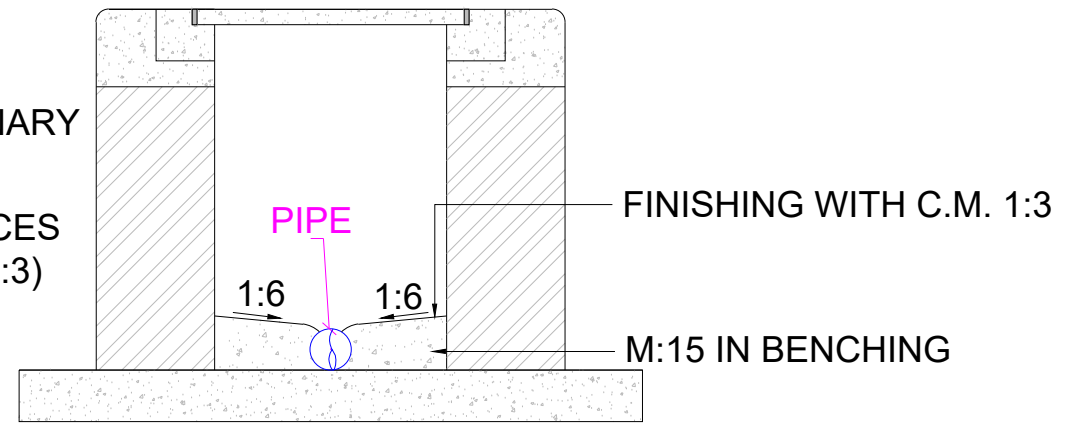
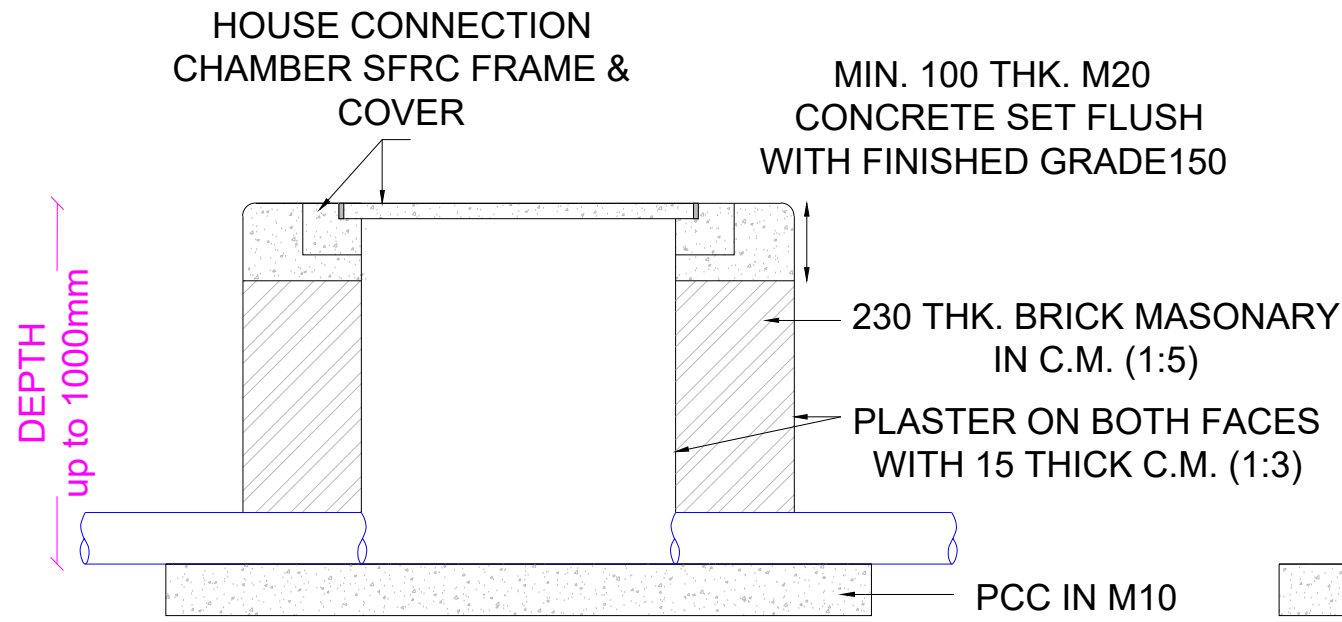

PLAN  
HOUSE CONNECTION CHAMBER  
SIZE: 455X610X1000mm

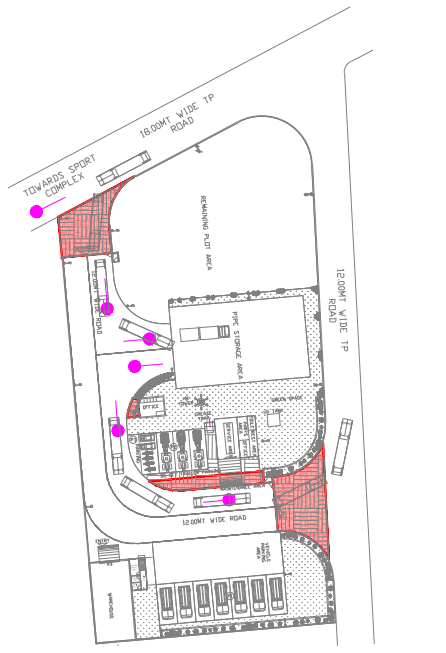
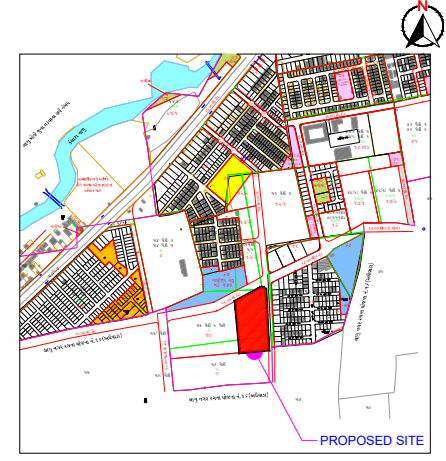

## TENDER DRAWING

NO	DATE	DESCRIPTION	SIGNATURE
PROJECT:- CONSULTANCY SERVICE FOR PREPARATION OF DPR, DTP AND PMC SERVICE OF SEWRAGE PROJECT UNDER AMRUT 2.0 OF BHAVNAGAR CITY.			

CLIENT:- THE EXECUTIVE ENGINEER, DRAINAGE DEPARTMENT, MUNICIPAL CORPORATION, CENTRAL OFFICE BUILDING, SIR MANGALSINHJI ROAD, BHAVNAGAR- 364001

CONSULTANT:- FACILE MAVEN PRIVATE LIMITED  
1701, 2 & 3, Rio Empire, Ph: + 91 - 261 - 6575998  
Opp. Pal RTO, Pal, Surat - Fax : + 91 - 261 - 2733584  
395009 Email : infra@facilemaven.com

TITLE:- TYPICAL DETAILS OF INSPECTION CHAMBER

DRAWN BY :-	AKSHAY	DESIGNED BY :-	B.K.PATEL
CHECKED BY :-	A.K.GARG	PROJ. NO. :-	-
SCALE :-	N.T.S	DRG. NO. :-	BMC/DSA/21
DATE :-	19/11/2024	REVISION :-	R0

# TYPICAL DETAILS OF MANHOLE

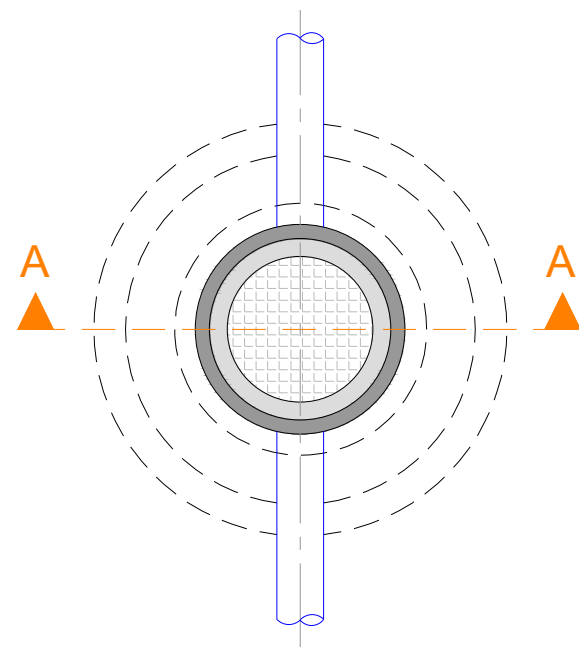
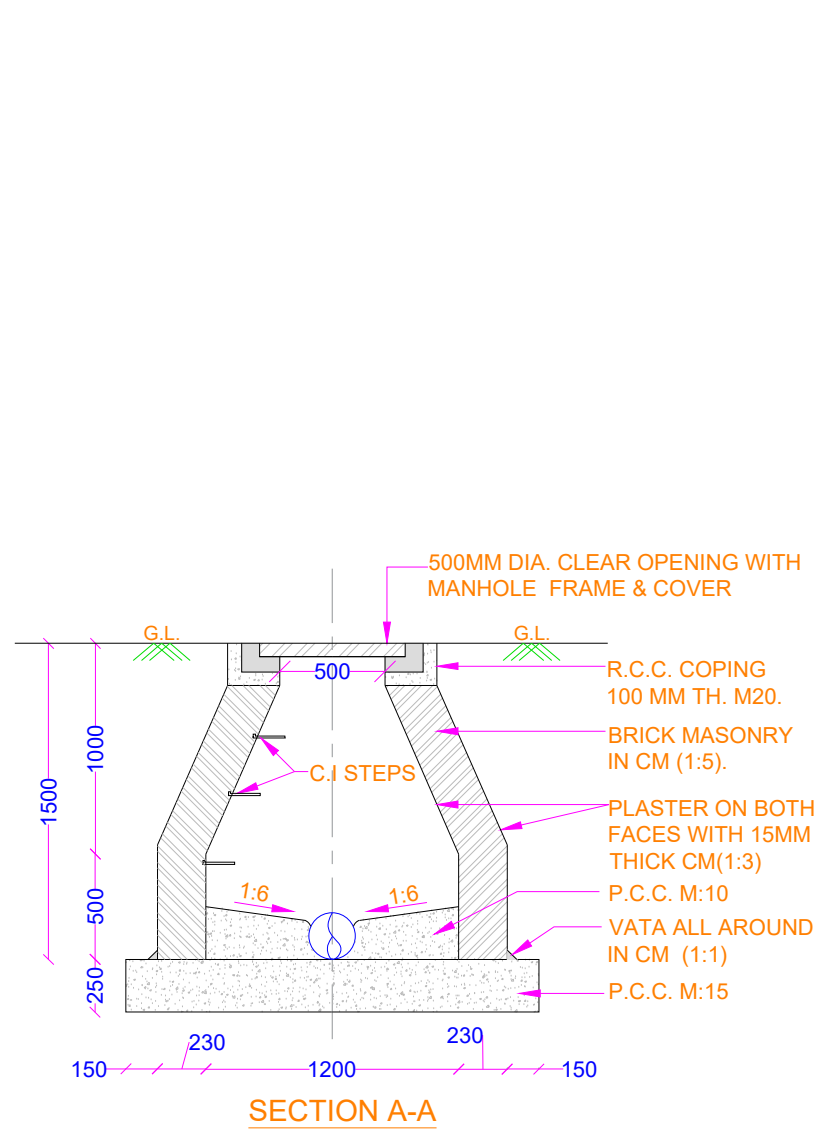

**TYPICAL DETAILS - 'A' TYPE**  
**MANHOLE-1200MM DIA**  
**UP TO 1500MM DEPTH**

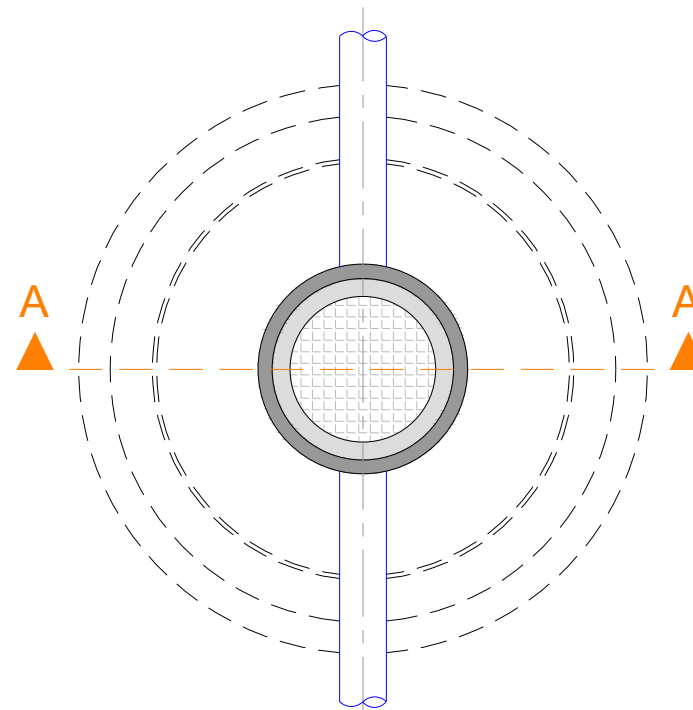
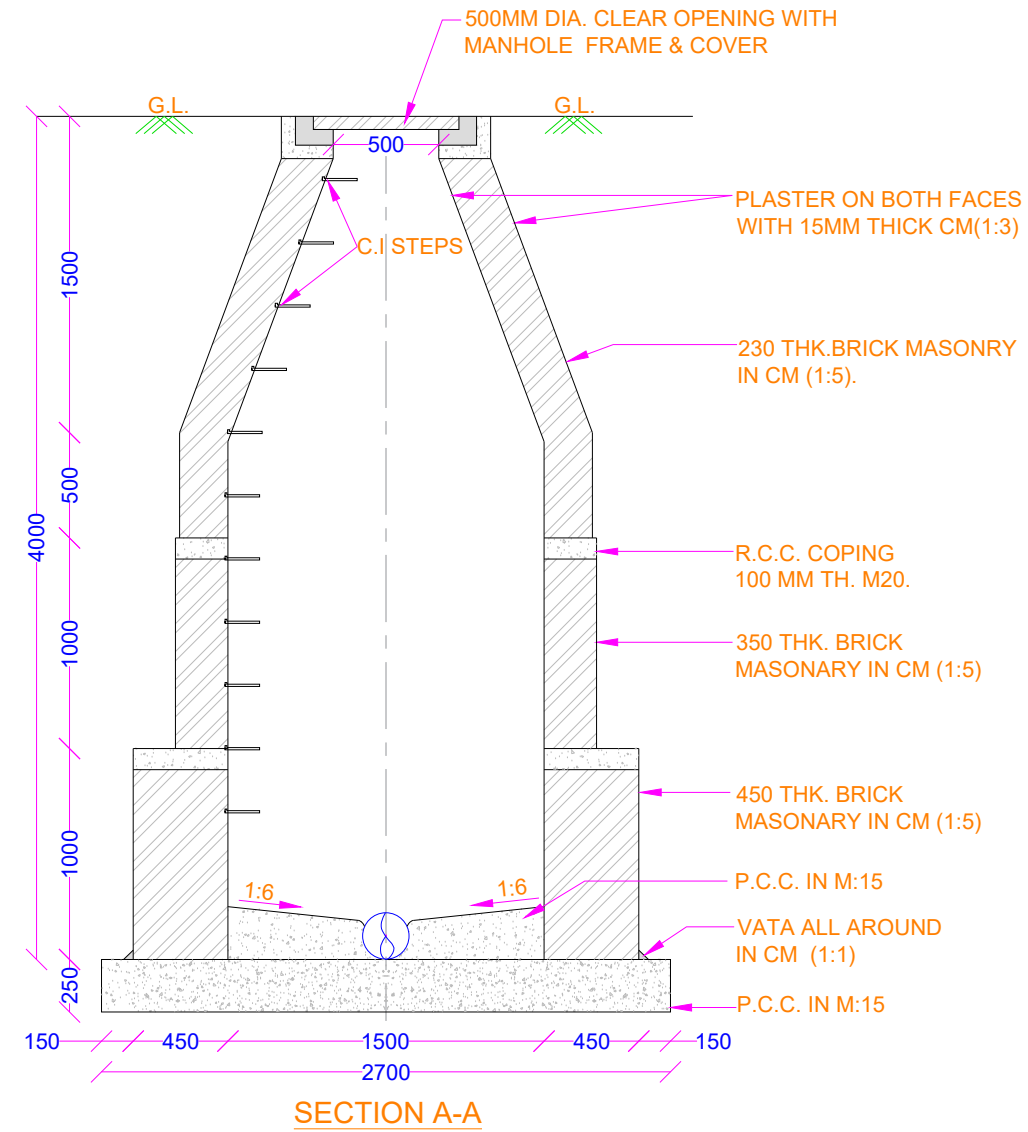

**'B' TYPE CIRCULAR MANHOLE**  
**FOR 150 MM Ø TO 600MMØ150 MM Ø TO 600MMØ**  
**(Depth 1.5m To 4.0m)**

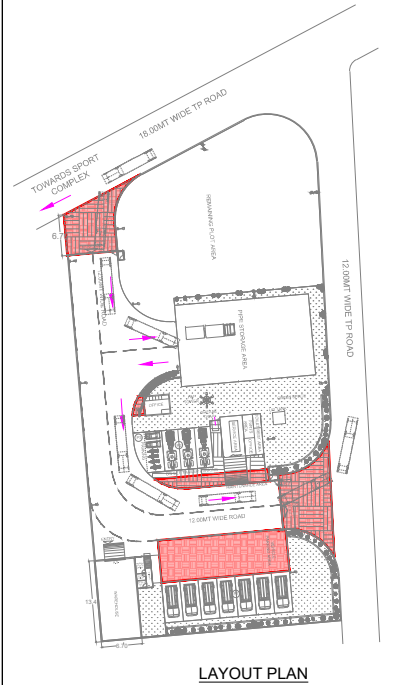
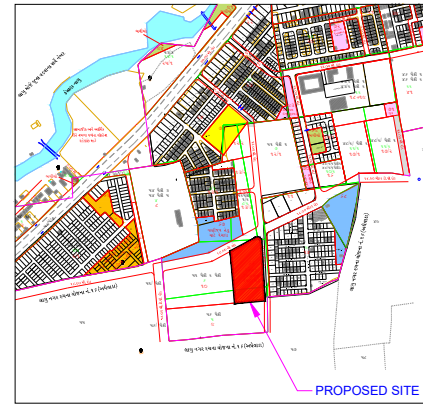

## TENDER DRAWING

NO	DATE	DESCRIPTION	SIGNATURE
----	------	-------------	-----------

PROJECT:- CONSULTANCY SERVICE FOR PREPARATION OF DPR, DTP AND PMC SERVICE OF SEWAGE PROJECT UNDER AMRUT 2.0 OF BHAVNAGAR CITY.

CLIENT:- THE EXECUTIVE ENGINEER, DRAINAGE DEPARTMENT, MUNICIPAL CORPORATION, CENTRAL OFFICE BUILDING, SIR MANGALSINHI ROAD, BHAVNAGAR- 364001

CONSULTANT:- FACILE MAVEN PRIVATE LIMITED  
 1701, 2 & 3, Rio Empire, Ph: + 91 - 261 - 6575998  
 Opp. Pal RTO, Pal, Surat - Fax : + 91 - 261 - 2733584  
 395009 Email : infra@facilemaven.com

TITLE:- TYPICAL DETAILS OF MANHOLE

DRAWN BY :-	AKSHAY	DESIGNED BY :-	B.K.PATEL
CHECKED BY :-	A.K.GARG	PROJ. NO. :-	-
SCALE :-	N.T.S	DRG. NO. :-	BMC/DSA/22
DATE :-	19/11/2024	REVISION :-	R0



# LAYOUT PLAN OF STORE AREA FOR DRAINAGE DEPARTMENT (FP NO. 66)

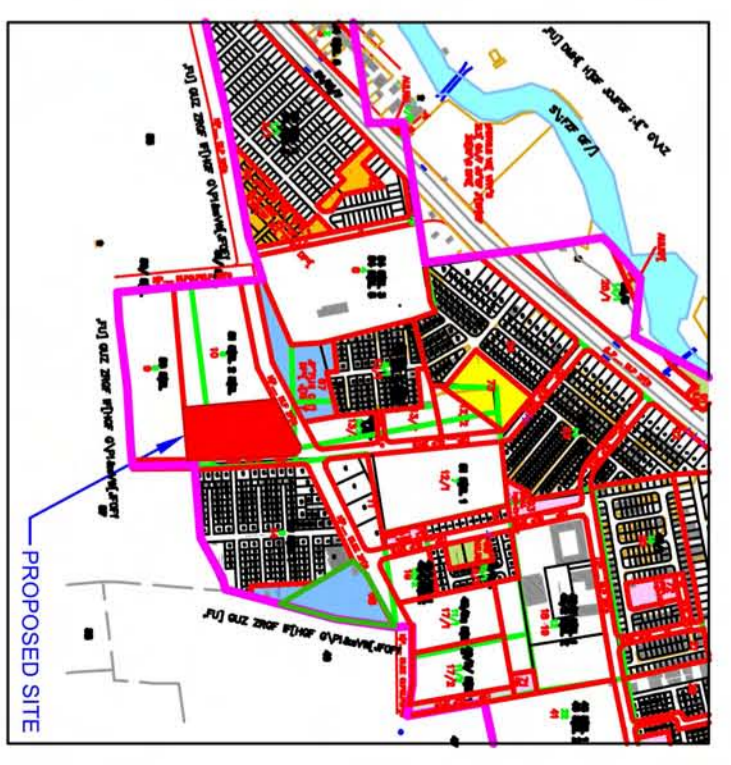
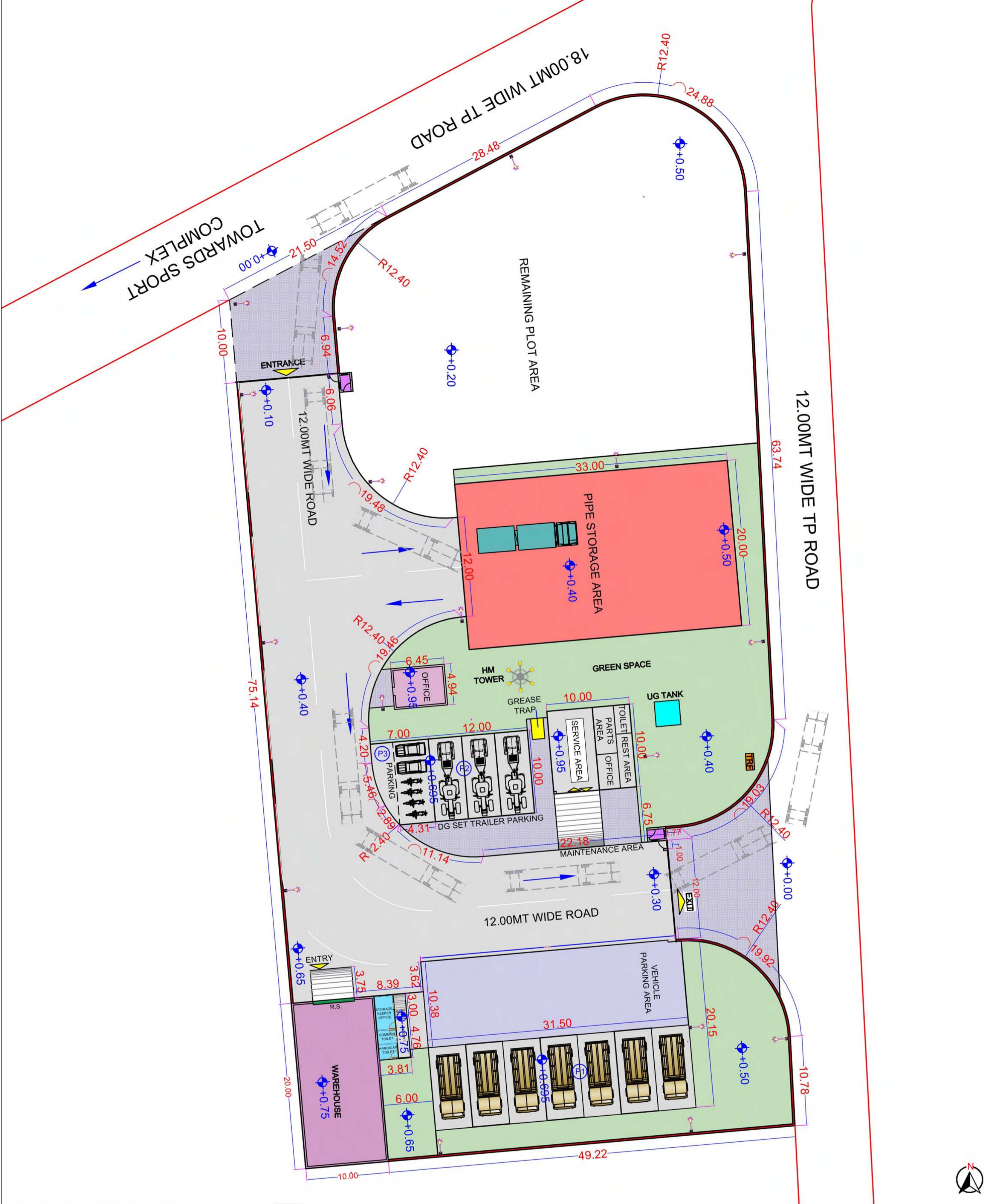

## TENDER DRAWING

NO	DATE	DESCRIPTION	SIGNATURE
R1	07-05-2024	OFFICE BUILDING SIZE	

PROJECT:- CONSULTANCY SERVICE FOR PREPARATION OF DPR, DTP AND PMC SERVICE OF SEWAGE PROJECT UNDER AMRUT 2.0 OF BHAYNAGAR CITY.

CLIENT:-  
 THE EXECUTIVE ENGINEER,  
 DRAINAGE DEPARTMENT, MUNICIPAL CORPORATION,  
 CENTRAL OFFICE BUILDING, SIR MANGALSIKHJI ROAD,  
 BHAYNAGAR- 364001

CONSULTANT:- FACILE MAVEN PRIVATE LIMITED  
 1701, 2 & 3, Rio Empire, Ph: + 91 -261 - 6575898  
 Opp. Pal RTO, Pal, Surat - Fax: + 91 -261 - 2733584  
 395009 Email: infra@facilemaven.com

TITLE:- LAYOUT PLAN OF STORE AREA FOR DRAINAGE DEPARTMENT

DRAWN BY :-	AKSHAY	DESIGNED BY :-	PURVA
CHECKED BY :-	A.K. GARG	PROJ. NO. :-	
SCALE :-	N.T.S	DRG. NO. :-	BMC/D5A/01
DATE :-	18/11/2024	REVISION :-	R1



# LAYOUT PLAN OF STORE AREA FOR DRAINAGE DEPARTMENT (FP NO. 66) ( LANDSCAPING )

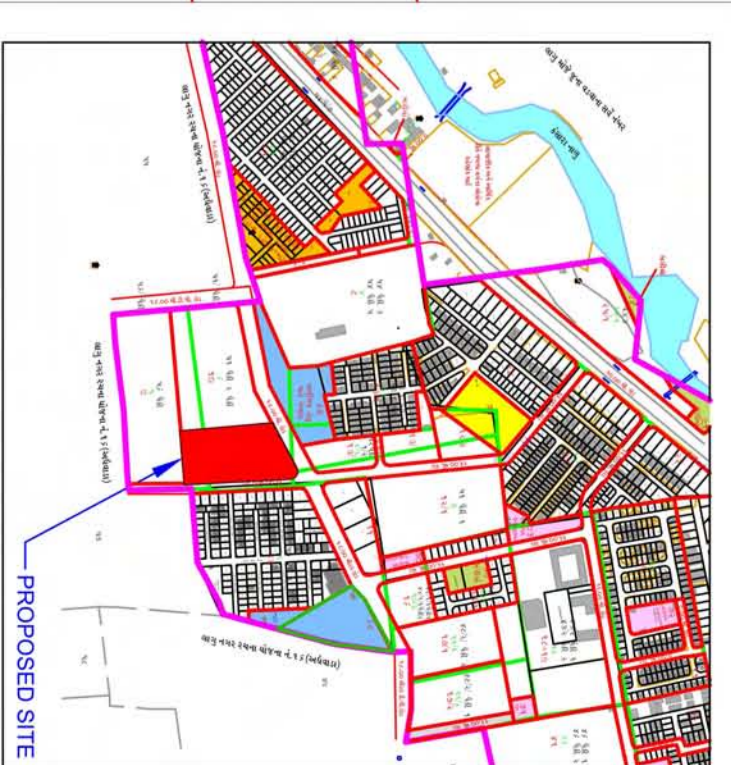
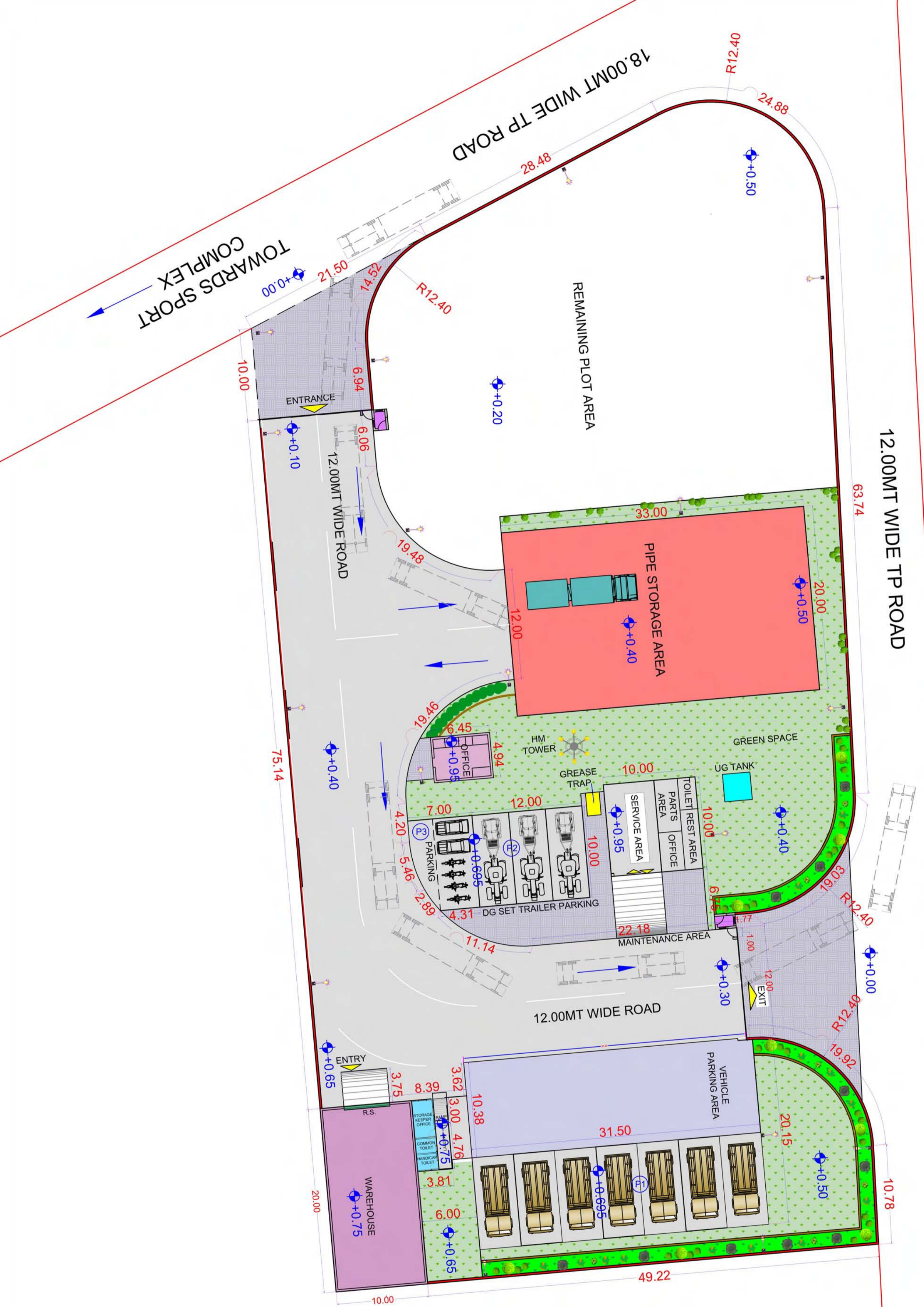

## TENDER DRAWING

R1	07-05-2024	OFFICE BUILDING SIZE	SIGNATURE
NO	DATE	DESCRIPTION	
PROJECT:- CONSULTANCY SERVICE FOR PREPARATION OF DPR, DTP AND PMC SERVICE OF SEWERAGE PROJECT UNDER AMRUT 2.0 OF BHAVNAGAR CITY.			
CLIENT:- THE EXECUTIVE ENGINEER, DRAINAGE DEPARTMENT, MUNICIPAL CORPORATION, CENTRAL OFFICE BUILDING, SIR MANGALSIKHJI ROAD, BHAVNAGAR-364001			
CONSULTANT:- FACILE MAVEN PRIVATE LIMITED 1701, 2 & 3, Rio Empire, Ph: + 91 - 261 - 6575998 Opp. Pal RT0, Pal, Surat - Fax: + 91 - 261 - 2733584 3950099 Email: infra@facilemaven.com			
TITLE:- LAYOUT PLAN OF STORE AREA FOR DRAINAGE DEPARTMENT (FP NO. 66) ( LANDSCAPING )			
DRAWN BY :-	AKSHAY	DESIGNED BY :-	PURVA
CHECKED BY :-	A.K. GARG	PROJ. NO. :-	-
SCALE :-	N.T.S	DRG. NO. :-	BMC/D5A/02
DATE :-	26/10/2024	REVISION :-	R1



# TYPICAL DETAILS OF COMPOUND WALL

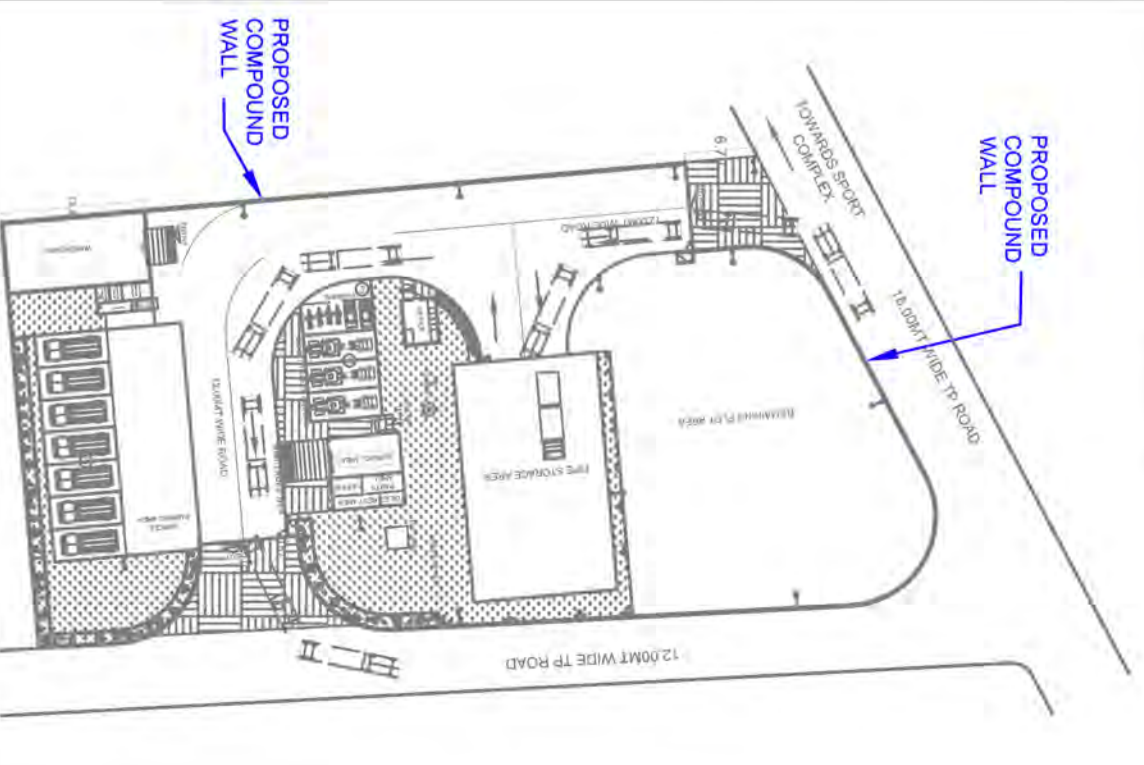
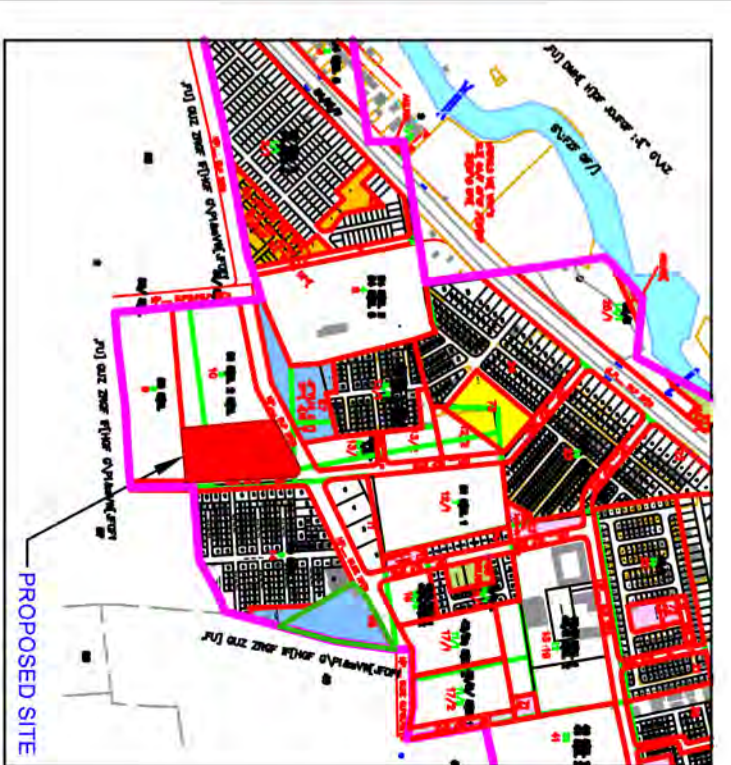
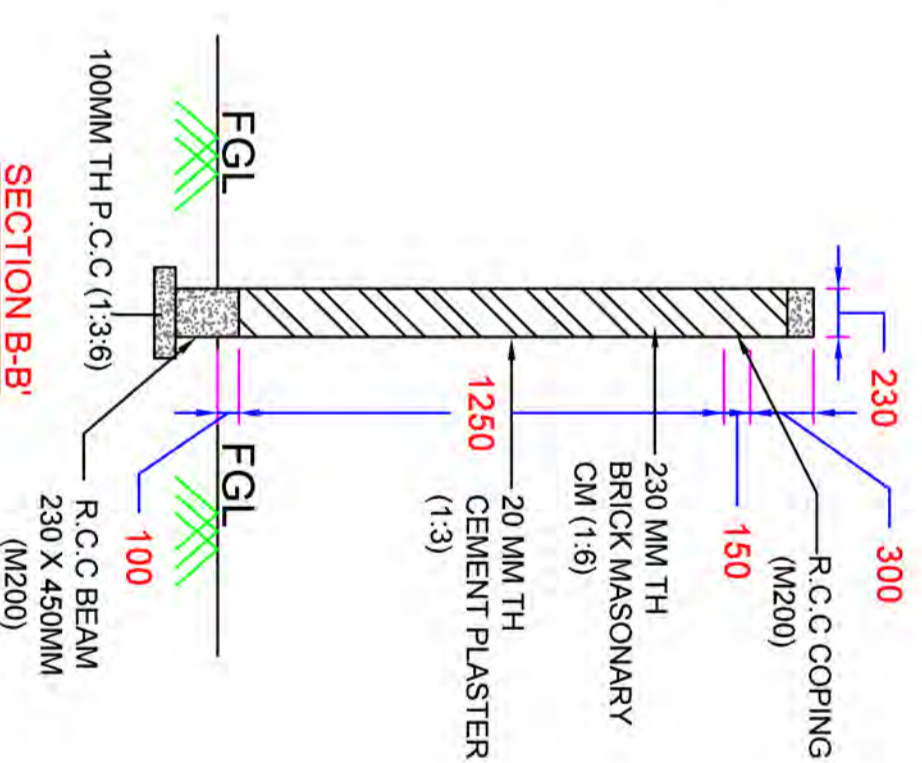
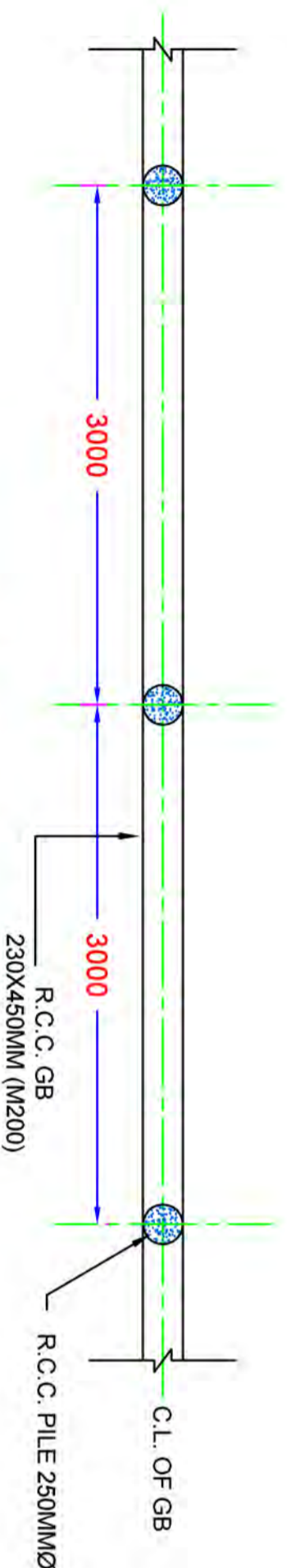
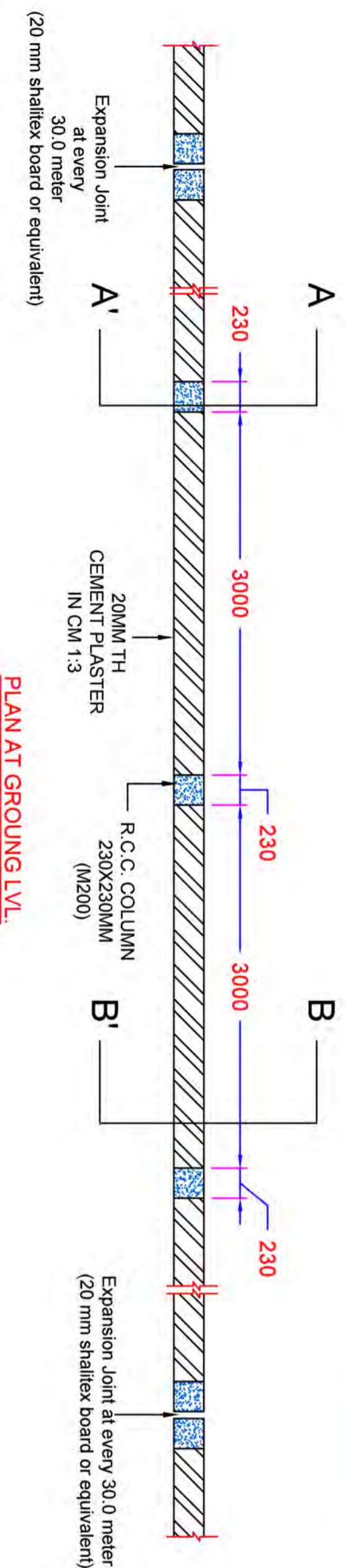
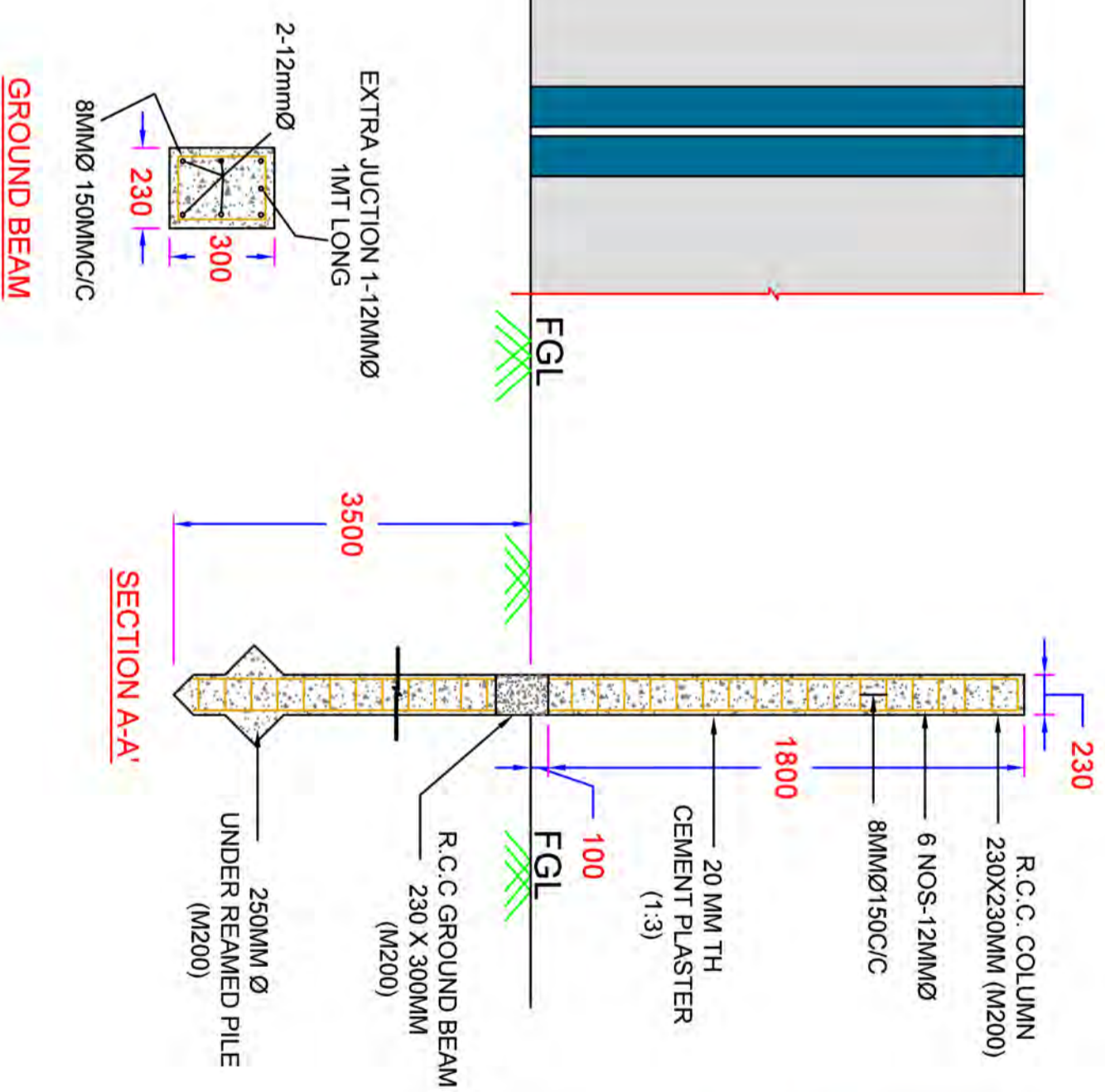
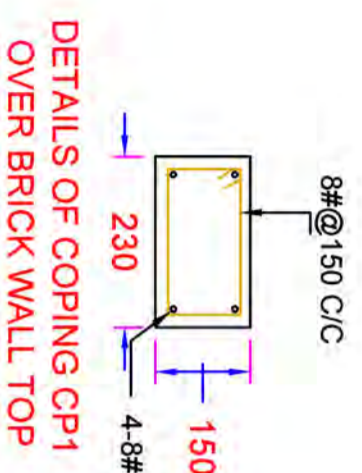
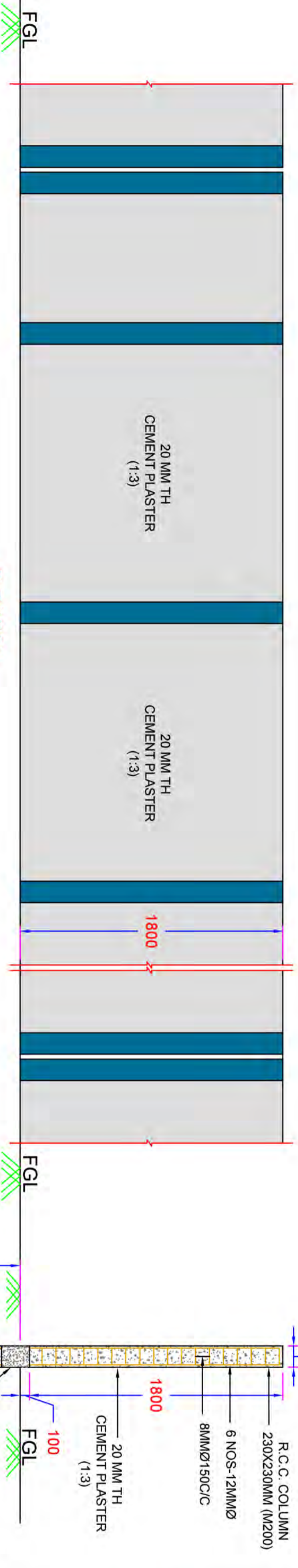

## TENDER DRAWING

NO	DATE	DESCRIPTION	SIGNATURE

PROJECT:- CONSULTANCY SERVICE FOR PREPARATION OF DPR, DTP AND PMC SERVICE OF SEWERAGE PROJECT UNDER AMRUT 2.0 OF BHAVNAGAR CITY.

CLIENT:- THE EXECUTIVE ENGINEER, DRAINAGE DEPARTMENT, MUNICIPAL CORPORATION, CENTRAL OFFICE BUILDING, SIR MANGALSHIMJI ROAD, BHAVNAGAR-364001

CONSULTANT:- FACILE MAVEN PRIVATE LIMITED  
 1701, 2 & 3, Rio Empire, Ph: + 91 - 261 - 6575988  
 Opp. Pal/RTO, Pal, Surat - Fax: + 91 - 261 - 2733584  
 395009 Email: infra@facilemaven.com

TITLE:- TYPICAL DETAILS OF COMPOUND WALL

DRAWN BY :-	AKSHAY	DESIGNED BY :-	PURVA
CHECKED BY :-	A.K. GARG	PROJ. NO. :-	-
SCALE :-	N.T.S	DRG. NO. :-	BMC/DSA/03
DATE :-	18/11/2024	REVISION :-	R0



# TYPICAL DETAILS OF ENTRY GATE

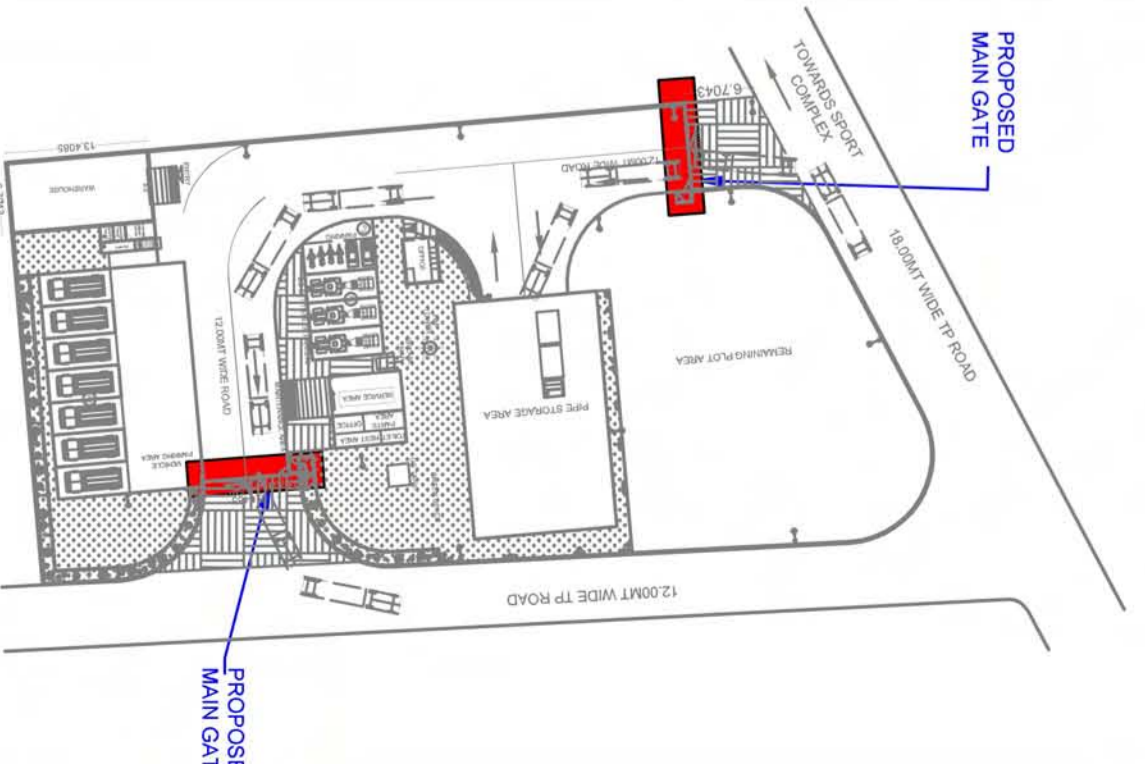
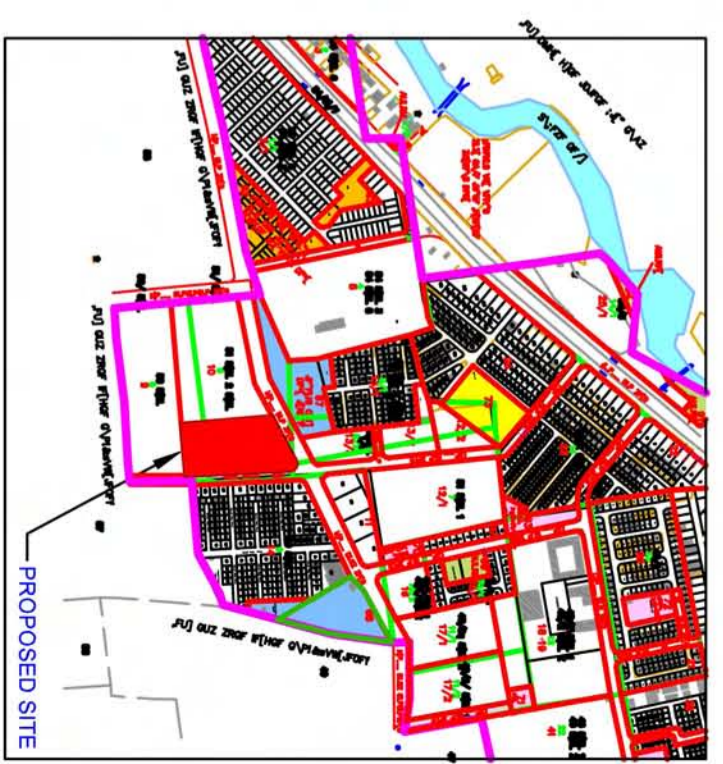
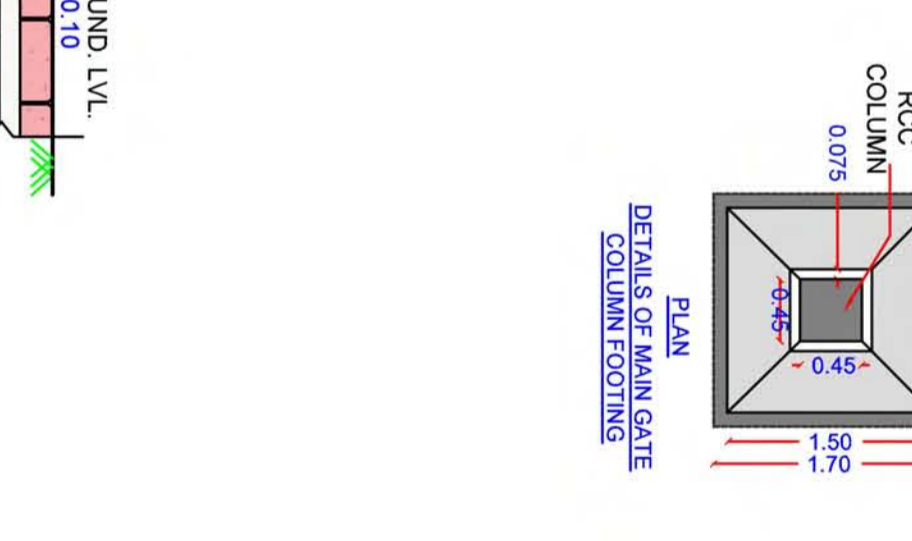
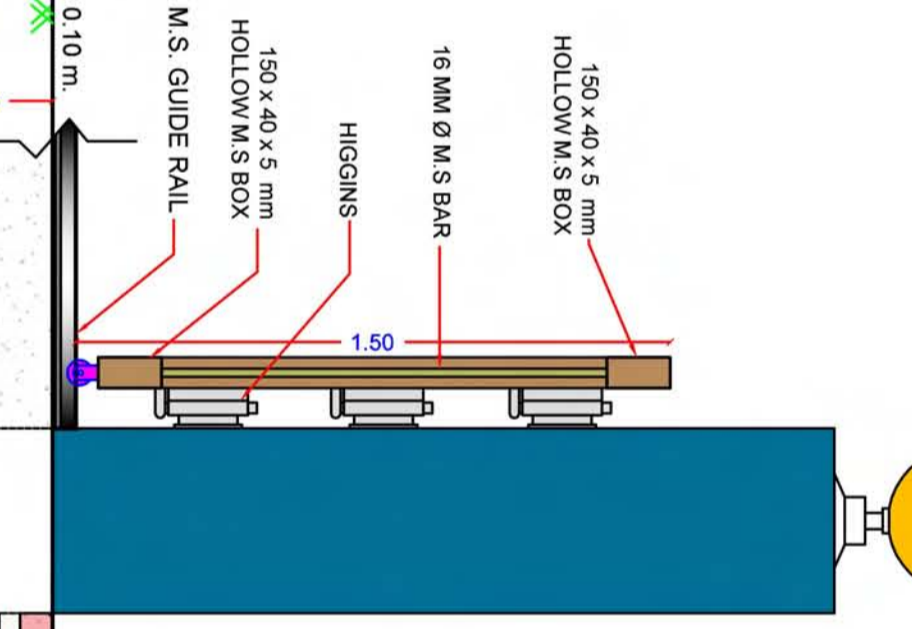
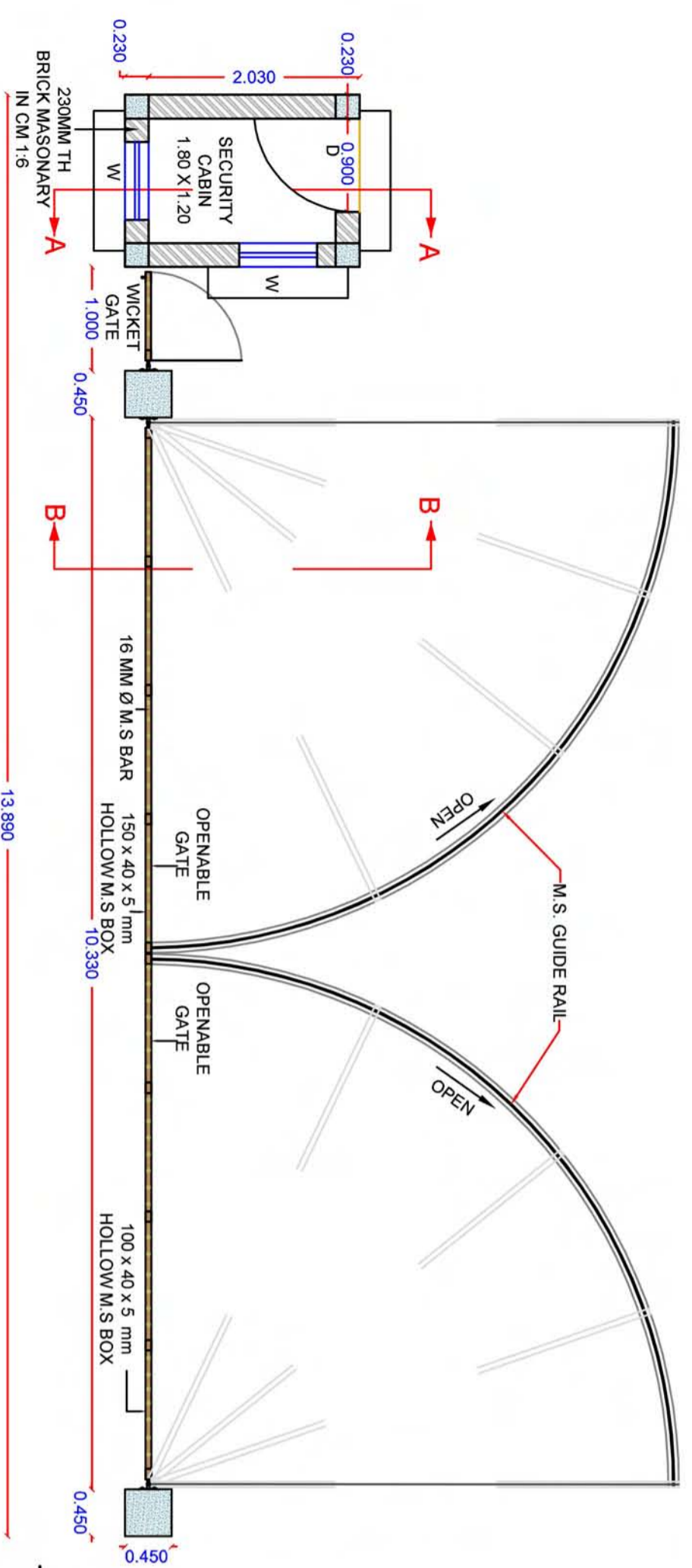
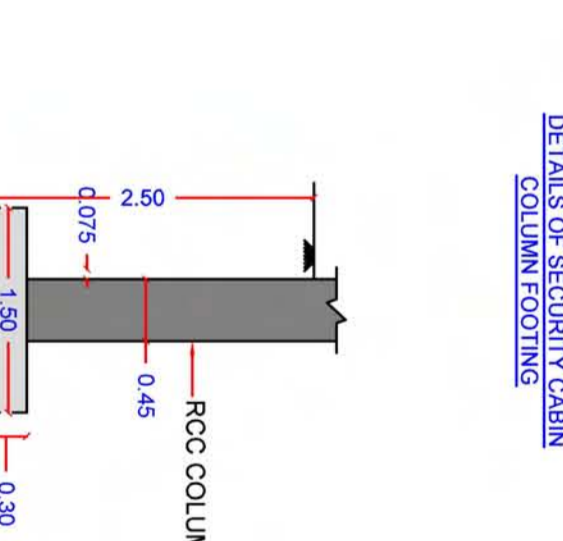
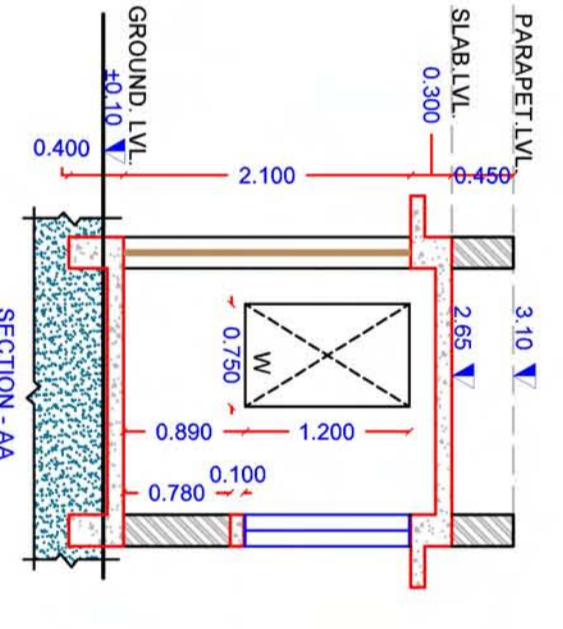
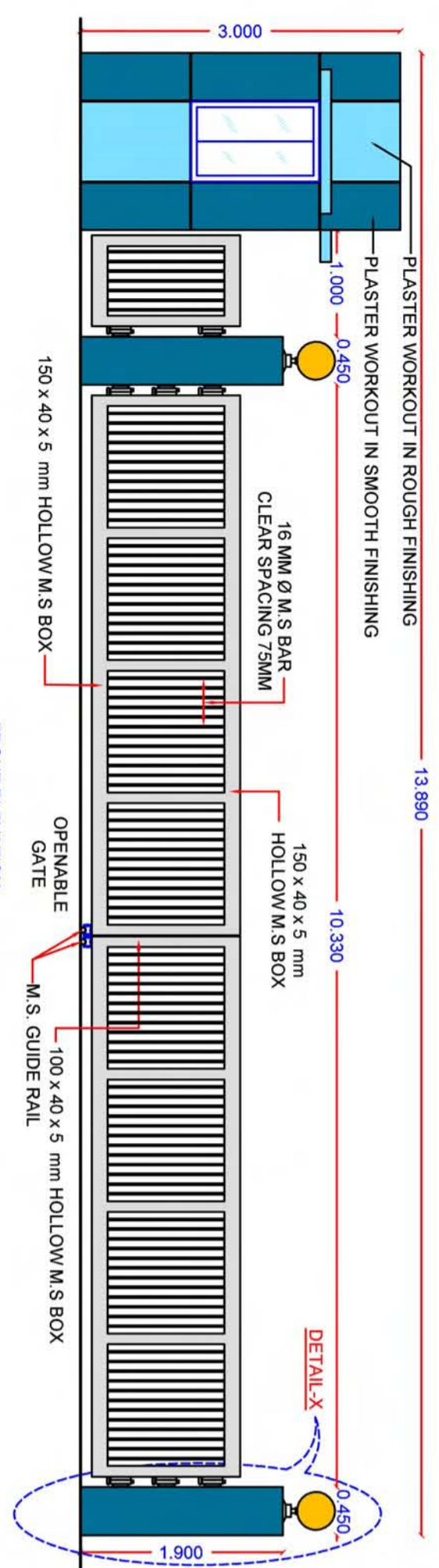
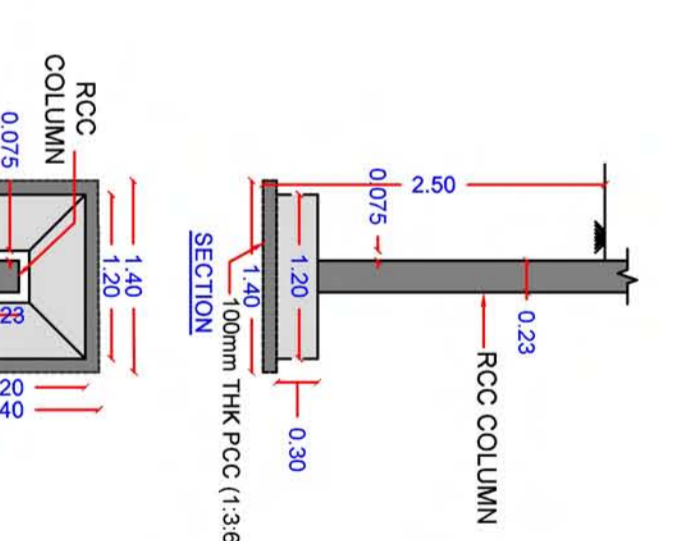
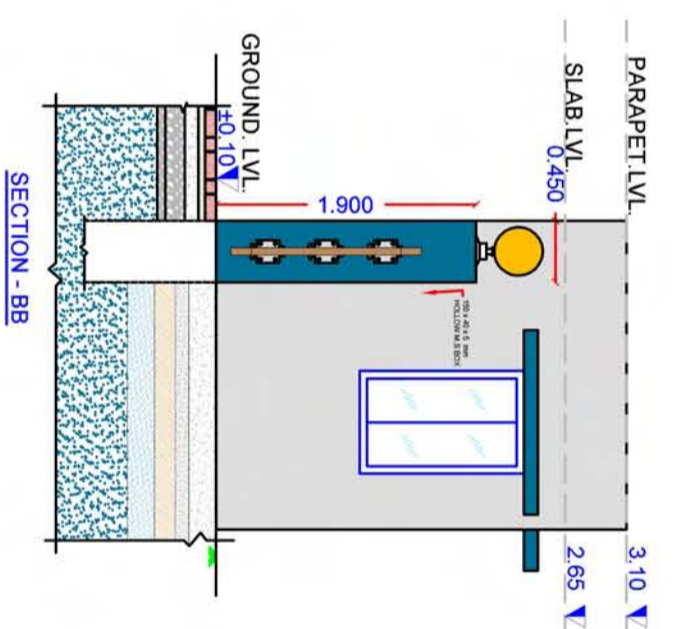
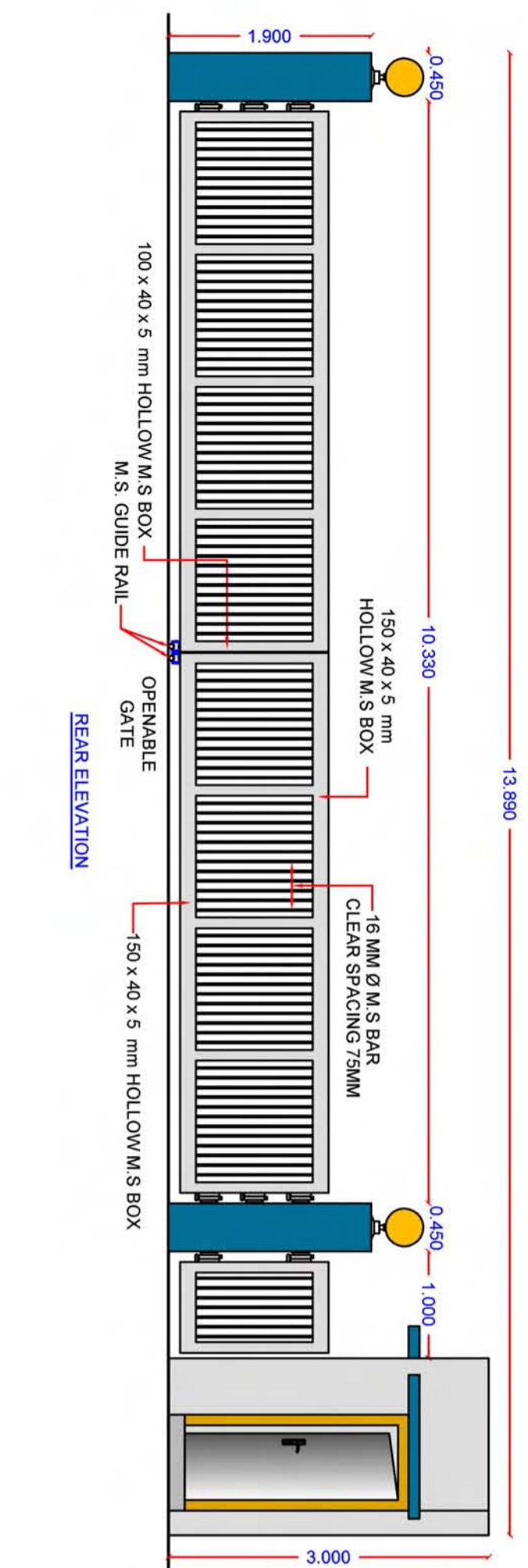

## TENDER DRAWING

NO	DATE	DESCRIPTION	SIGNATURE

**CLIENT:-** THE EXECUTIVE ENGINEER, DRAINAGE DEPARTMENT, MUNICIPAL CORPORATION, CENTRAL OFFICE BUILDING, SIR MANGALSINHJI ROAD, BHAVNAGAR-364001

**CONSULTANT:-** FACILE MAVEN PRIVATE LIMITED  
1701, 2 & 3, Rio Empire, Ph. + 91 - 261 - 6575998  
Opp. Pal RT0, Pal, Surat - Fax: + 91 - 261 - 2733584  
395009 Email: info@facilemaven.com

**TITLE:-** DETAILS OF ENTRY MAIN GATE

DRAWN BY :-	AKSHAY	DESIGNED BY :-	PURVA
CHECKED BY :-	A.K. GARG	DRG. NO. :-	BMC/DSA/04
SCALE :-	N.T.S	REVISION :-	R0
DATE :-	18/11/2024		



